

Chapter 6

Input Tax Credit

Sections	Rules
16. Eligibility and conditions for taking input tax credit.	36. Documentary requirements and conditions for claiming input tax credit
17. Apportionment of credit and blocked credits.	37. Reversal of input tax credit in the case of non-payment of consideration
18. Availability of credit in special circumstances.	38. Claim of credit by a banking company or a financial institution
19. Taking input tax credit in respect of inputs and capital goods sent for job work.	39. Procedure for distribution of input tax credit by Input Service Distributor
20. Manner of distribution of credit by Input Service Distributor.	40. Manner of claiming credit in special circumstances
21. Manner of recovery of credit distributed in excess	41. Transfer of credit on sale, merger, amalgamation, lease or transfer of a business
	42. Manner of determination of input tax credit in respect of inputs or input services and reversal thereof
	43. Manner of determination of input tax credit in respect of capital goods and reversal thereof in certain cases
	44. Manner of reversal of credit under special circumstances
	44A. Manner of reversal of credit of Additional duty of Customs in respect of Gold dore bar
	45. Conditions and restrictions in respect of inputs and capital goods sent to the job worker

Statutory Provisions- Effective from 1st July, 2017 to 31st January, 2019**16. Eligibility and conditions for taking input tax credit**

- (1) *Every registered person shall, subject to such conditions and restrictions as may be prescribed and in the manner specified in section 49, be entitled to take credit of input tax charged on any supply of goods or services or both to him which are used or intended to be used in the course or furtherance of his business and the said amount shall be credited to the electronic credit ledger of such person.*
- (2) *Notwithstanding anything contained in this section, no registered person shall be entitled to the credit of any input tax in respect of any supply of goods or services or both to him unless, -*
- (a) *he is in possession of a tax invoice or debit note issued by a supplier registered under this Act, or such other tax paying documents as may be prescribed;*
- (b) *he has received the goods or services or both*
Explanation.—For the purposes of this clause, it shall be deemed that the registered person has received the goods where the goods are delivered by the supplier to a recipient or any other person on the direction of such registered person, whether acting as an agent or otherwise, before or during movement of goods, either by way of transfer of documents of title to goods or otherwise;
- (c) *subject to the provisions of section 41, the tax charged in respect of such supply has been actually paid to the Government, either in cash or through utilization of input tax credit admissible in respect of the said supply; and*
- (d) *he has furnished the return under section 39:*
Provided that where the goods against an invoice are received in lots or instalments, the registered person shall be entitled to take credit upon receipt of the last lot or instalment:
Provided further that where a recipient fails to pay to the supplier of goods or services or both, other than the supplies on which tax is payable on reverse charge basis, the amount towards the value of supply along with tax payable thereon within a period of one hundred and eighty days from the date of issue of invoice by the supplier, an amount equal to the input tax credit availed by the recipient shall be added to his output tax liability, along with interest thereon, in such manner as may be prescribed:
Provided also that the recipient shall be entitled to avail of the credit of input tax on payment made by him of the amount towards the value of supply of goods or services or both along with tax payable thereon.
- (3) *Where the registered person has claimed depreciation on the tax component of the cost of capital goods and plant and machinery under the provisions of the Income Tax Act, 1961, the input tax credit on the said tax component shall not be allowed.*

- (4) *A registered person shall not be entitled to take input tax credit in respect of any invoice or debit note for supply of goods or services or both after the due date of furnishing of the return under section 39 for the month of September following the end of financial year to which such invoice or invoice relating to such debit note pertains or furnishing of the relevant annual return, whichever is earlier.*

Statutory Provisions- Effective from 1st February 2019 vide The Central Goods & Services Tax Amendment Act,2018

16. Eligibility and conditions for taking input tax credit

- (2) *Every registered person shall, subject to such conditions and restrictions as may be prescribed and in the manner specified in section 49, be entitled to take credit of input tax charged on any supply of goods or services or both to him which are used or intended to be used in the course or furtherance of his business and the said amount shall be credited to the electronic credit ledger of such person.*
- (2) *Notwithstanding anything contained in this section, no registered person shall be entitled to the credit of any input tax in respect of any supply of goods or services or both to him unless, -*
- (a) *he is in possession of a tax invoice or debit note issued by a supplier registered under this Act, or such other tax paying documents as may be prescribed;*
- (b) *he has received the goods or services or both*
- Explanation—For the purposes of this clause, it shall be deemed that the registered person has received the goods or, as the case may be, services—*
- (i) *where the goods are delivered by the supplier to a recipient or any other person on the direction of such registered person, whether acting as an agent or otherwise, before or during movement of goods, either by way of transfer of documents of title to goods or otherwise;*
- (ii) *where the services are provided by the supplier to any person on the direction of and on account of such registered person*
- (c) *subject to the provisions of section 41, the tax charged in respect of such supply has been actually paid to the Government, either in cash or through utilization of input tax credit admissible in respect of the said supply; and*
- (d) *he has furnished the return under section 39:*
- Provided that where the goods against an invoice are received in lots or instalments, the registered person shall be entitled to take credit upon receipt of the last lot or instalment:*
- Provided further that where a recipient fails to pay to the supplier of goods or services or both, other than the supplies on which tax is payable on reverse charge*

basis, the amount towards the value of supply along with tax payable thereon within a period of one hundred and eighty days from the date of issue of invoice by the supplier, an amount equal to the input tax credit availed by the recipient shall be added to his output tax liability, along with interest thereon, in such manner as may be prescribed:

Provided also that the recipient shall be entitled to avail of the credit of input tax on payment made by him of the amount towards the value of supply of goods or services or both along with tax payable thereon.

- (3) Where the registered person has claimed depreciation on the tax component of the cost of capital goods and plant and machinery under the provisions of the Income Tax Act, 1961, the input tax credit on the said tax component shall not be allowed.*
- (4) A registered person shall not be entitled to take input tax credit in respect of any invoice or debit note for supply of goods or services or both after the due date of furnishing of the return under section 39 for the month of September following the end of financial year to which such invoice or invoice relating to such debit note pertains or furnishing of the relevant annual return, whichever is earlier.*

Extract of the CGST Rules, 2017

36. Documentary requirements and conditions for claiming input tax credit.

- 1) The input tax credit shall be availed by a registered person, including the Input Service Distributor, on the basis of any of the following documents, namely,-*
 - (a) an invoice issued by the supplier of goods or services or both in accordance with the provisions of section 31;*
 - (b) an invoice issued in accordance with the provisions of clause (f) of sub-section (3) of section 31, subject to the payment of tax;*
 - (c) a debit note issued by a supplier in accordance with the provisions of section 34;*
 - (d) a bill of entry or any similar document prescribed under the Customs Act, 1962 or rules made thereunder for the assessment of integrated tax on imports;*
 - (e) an Input Service Distributor invoice or Input Service Distributor credit note or any document issued by an Input Service Distributor in accordance with the provisions of sub-rule (1) of rule 54.*
- 2) Input tax credit shall be availed by a registered person only if all the applicable particulars as specified in the provisions of Chapter VI are contained in the said document, and the relevant information, as contained in the said document, is furnished in FORMGSTR-2 by such person.*

Provided that if the said document does not contain all the specified particulars but contains the details of the amount of tax charged, description of goods or services, total value of supply of goods or services or both, GSTIN of the supplier and recipient and place of supply in case of inter-State supply, input tax credit may be availed by such registered person.¹

- 3) *No input tax credit shall be availed by a registered person in respect of any tax that has been paid in pursuance of any order where any demand has been confirmed on account of any fraud, willful misstatement or suppression of facts.*

37. Reversal of input tax credit in case of non-payment of consideration.

- 1) *A registered person, who has availed of input tax credit on any inward supply of goods or services or both, but fails to pay to the supplier thereof, the value of such supply along with the tax payable thereon, within the time limit specified in the second proviso to subsection(2) of section 16, shall furnish the details of such supply, the amount of value not paid and the amount of input tax credit availed of proportionate to such amount not paid to the supplier in FORM GSTR-2 for the month immediately following the period of one hundred and eighty days from the date of the issue of the invoice.*

Provided that the value of supplies made without consideration as specified in Schedule I of the said Act shall be deemed to have been paid for the purposes of the second proviso to sub-section (2) of section 16.

Provided further that the value of supplies on account of any amount added in accordance with the provisions of clause (b) of sub-section (2) of section 15 shall be deemed to have been paid for the purposes of the second proviso to sub-section (2) of section 16²

- 2) *The amount of input tax credit referred to in sub-rule (1) shall be added to the output tax liability of the registered person for the month in which the details are furnished.*
- 3) *The registered person shall be liable to pay interest at the rate notified under sub-section (1) of section 50 for the period starting from the date of availing credit on such supplies till the date when the amount added to the output tax liability, as mentioned in sub-rule (2), is paid.*
- 4) *The time limit specified in sub-section (4) of section 16 shall not apply to a claim for re-availing of any credit, in accordance with the provisions of the Act or the provisions of this Chapter, that had been reversed earlier.*

¹ Inserted by the Central Goods and Services Tax (Eight Amendment) Rules, 2018 w.e.f. 04.09.2018.

² Inserted by the Central Goods and Service Tax (Fifth Amendment), Rules, 2018 w.e.f. 13.06.2018.

Relevant circulars, notifications, clarifications issued by Government

1. Chapter Nineteen of the compilation of the GST Flyers as issued by the CBIC on 'Input Tax Credit Mechanism in GST'

Related Provisions of the Statute

Section or Rule	Description
Section 17	Apportionment of credit and blocked credits
Section 31	Tax invoice.
Section 34	Credit and debit notes
Section 39	Furnishing of returns.
Section 41	Claim of input tax credit and provisional acceptance thereof
Section 43A	Procedure for furnishing return and availing input tax credit
Section 49	Payment of tax, interest, penalty and other amounts
Schedule I	Activities to be treated as supply even if made without consideration
Rule 54	Tax invoice in special cases
Rule 86	Electronic Credit Ledger

16.1 Introduction

Chapter V of CGST Act deals with input tax credit. The availment or otherwise of Input Tax Credit forms the cornerstone in a GST regime. GST can be understood as a system of value-added tax on goods and / or services. It is these provisions of Input Tax Credit that make GST a value-added tax i.e., collection of tax at all points in the supply chain after allowing for credit of taxes paid on inputs / input services and capital goods. The invoice method of value added taxation has been followed in the GST regime too, viz., the tax paid at the time of receipt of goods or services or both would be eligible for set-off against the tax payable on supply of goods or services or both, based on the invoices with a special emphasis on actual payment of tax by the supplier. As on date, there is a debate going on between the tax payer and the Government as to whether the emphasis placed by the Statute on payment of taxes by the Supplier to enable a Recipient to avail credit, is fair or not and whether it adds on to the compliance burden or not. The procedures and restrictions laid down in these provisions are important to make sure that there is seamless flow of credit in the whole scheme of taxation without any misuse.

16.2 Analysis**(i) Relevant definitions:**

- (a) **Taxable person (2(107)):** Means a person who is registered or liable to be registered under section 22 or section 24. As such, the liability to pay tax devolves on every

'taxable person' whether or not registration has been sought. A plain reading of the input tax credit provisions makes it clear that input tax credit would be available only to a registered person and to a limited extent pre-registration credits are available under section 18(1).

In case taxes are paid after registration for past periods, the credit for period beyond 1 month from registration may not be available even if it is a bona fide error. This may not be the intention but law does not enable such credits. (However, credit for period beyond 1 month from registration only holds true in cases where a person applies for registration within a period of 30 days from the date on which he becomes liable to obtain registration)

- (b) **Input tax credit:** means the credit of "input tax" in terms of section 2(63).
- (c) **Input tax:** "Input tax" in terms of section 2(62) in relation to a registered person, means the Central tax, State tax, Integrated tax or Union territory tax charged on any supply of goods or services or both made to him and includes:
- integrated goods and service tax (IGST) charged on import of goods.
 - tax payable on reverse charge basis under IGST Act /SGST Act /CGST Act /UTGST Act.
 - but excludes tax paid as a composition levy.
- Section 9(3) and 9(4) of CGST Act (similarly section 5(3) and 5(4) of the IGST Act) levies tax on goods or services or both on reverse charge.
- Therefore, 'input tax credit' is the tax paid by a registered person under the Act whether as a forward charge or reverse charge for the use of such goods or services or both in the course or furtherance of his business.
- (d) **Electronic credit ledger:** The input tax credit as self-assessed in the return of registered person shall be credited to electronic credit ledger in accordance with section 41, to be maintained in the manner as may be prescribed. [Section 2(46) read with Section 49(2)].
- (e) **"Capital goods"** means goods, the value of which is capitalised in the books of account of the person claiming the input tax credit and which are used or intended to be used in the course or furtherance of business [Section 2(19)].
- (f) **Input:** "Input" in terms of section 2(59) means
- any goods,
 - other than capital goods,
 - used or intended to be used by a supplier
 - in the course or furtherance of business

- (g) **Input service:** “Input service” in terms of section 2(60) means
- any service
 - used or intended to be used by a supplier
 - in the course or furtherance of business.
- (h) **“Works Contract”** in terms of Section 2(119) means a contract for building, construction, fabrication, completion, erection, installation, fitting out, improvement, modification, repair, maintenance, renovation, alteration or commissioning of any immovable property wherein transfer of property in goods (whether as goods or in some other form) is involved in the execution of such contract;
- (ii) **Section 16**
- (a) **Registered person to avail credit:** Every registered person subject to Section 49 (payment of tax), shall be entitled to take credit of input tax charged on any supply of goods or services or both to him which are used or intended to be used in the course or furtherance of his business. The input tax credit is credited to the electronic credit ledger. Rule 36 of the Central Goods and Service Tax Rules, 2017 provides that input tax credit can be taken on the basis of any of the following documents:
- (i) Invoice issued under section 31 by supplier of goods or services.
 - (ii) Debit note issued under section 34 by supplier of goods or services.
 - (iii) Bill of entry or any similar documents under Custom Act, 1962.
 - (iv) Invoice prepared in respect of supplies made under reverse charge basis issued u/s 31(3)(f).
 - (v) Invoice/ Credit Note issued by ISD for distribution of credit in accordance with Rule 54(1) of CGST Rules, 2017.

It is important to observe the words ‘used by him’ and ‘in his business’ as appearing in section 16(1). These words refer to the registered taxable person in question and not the legal entity. So, input tax paid in a State must not be in relation to the business of a taxable person in another State, albeit belonging to the same person. For example, A Company has Branch-A which is a registered taxable person in Andhra Pradesh conducts conference in a hotel in Lonavla (Maharashtra) where CGST-SGST is charged by the hotel. This Company also has Branch-M which is a registered taxable person in Mumbai, Now the provisions of section 16(1) operate as follows:

- CGST-SGST charged by the hotel in Lonavla (Maharashtra) is ‘used in the business of Branch-A’ in Andhra Pradesh and not in the business of Branch-M in Mumbai.
- Hotel would not be aware about the above fact and would not resist to issue the bill in the name of Branch-M because both are branches of the same Company

- Since, CGST-SGST has been charged by the hotel, input tax credit would not be available to Branch-A as tax paid in Maharashtra is not a creditable tax in Andhra Pradesh
 - Branch-M may be compelled to forego the tax paid to the hotel. However, there may be an urge to save this loss by providing the GSTIN of Branch-M to the hotel. In fact, the Company is rightly required to obtain ISD registration in Maharashtra and distribute this credit entirely to Andhra Pradesh.
 - But, Branch-M in Mumbai cannot justify this input tax credit as it is not **'used by him'** in **'his business'** but it is 'used by another' in 'that others business'
 - Care should be taken to verify 'whose' business each input tax credit relates to;
 - If nexus is established between the services of the hotel and the 'business' of Branch-M, input tax credit may be availed by Branch-M. Nexus emerges if inter-branch supply of services occurs between Branch-M and Branch-A
 - Alternatively, based on the amount of credits of Branch-A lying as CGST + MGST credits, the company may decide to obtain ISD registration in the State of Maharashtra and transfer the credits as IGST from Maharashtra to Andhra Pradesh
- (b) **Wastage of inputs in the course of production:** Credit in respect of inputs that may have been wasted during the course of production of finished products does not cease to be *'used or intended to be used' in the course or furtherance of business*. As such, there is no restriction to read into the language of section 16 (1). In fact, the full extent of credit would be available whether the extent of wastage of inputs in the course of production of finished goods is within normal wastage norms or even exceeds that to be called abnormal wastage of inputs. Unless there is a diversion of inputs (in respect of which credit has been availed), there is no embargo on availment and retention of input tax credit. Section 17(5)(h) restricts credit on "goods lost" since these can no longer be used for the purpose of business but does not provide for restriction of credits on "loss of goods" which could be a process loss inherent to the nature of product on which credit has been availed. Therefore, "goods lost" must be given a completely different meaning as compared to "goods lost during production / process or a normal / abnormal loss".
- (c) **Input-Output nexus:** The erstwhile CENVAT Credit Rules, 2004 allowed for credits on input and input services used for manufacture of excisable goods or for rendering taxable services. The credit under GST law is available on procurements which are "used" or "intended to be used" in the course or furtherance of business. Hence, any procurements though not having any remote connection with the manufacturing or rendering of outward supplies, would also qualify for input tax credit so long as it is used or intended to be used for the purpose of business. Eg. Air Conditioner installed

in the cabin of the Managing Director, Maharashtra has no correlation with the car manufactured at the Company Plant in Gujarat but the credit of tax relating to such air conditioner would be available since the air conditioner has been installed for the purpose of business.

- (d) **Costing-pricing inter-relationship:** Credit may be availed in respect of inputs whose cost may not be included in the pricing of the product and consequently, not included in the transaction value – this may create a concern as to whether this credit is admissible or not. As explained by the Hon'ble Supreme Court in CCE, Pune v. Dai Ichi Karkaria 1999 (112) ELT 353, the nature of Modvat scheme is such that the cost of purchase of inputs lowered due to availment of credit, does not immediately, directly and proportionately impact the assessable value of the finished product manufactured using the inputs. The ratio of this judgement must be understood to continue to be applicable in the context of GST law, as well. As such, neither availment of credit nor its discontinuation can be alleged to have an immediate, direct and proportionate effect on the transaction value under section 15. However, the implications under Anti-Profiteering provisions of the GST Law should be borne in mind while deciding on the pricing and net benefit of tax due to introduction of GST.
- (e) **Time limit to avail the input tax credit:** A registered person is not entitled to avail input tax credit on tax invoice/ debit notes after the due date of furnishing of the return under section 39 for the month of September of the subsequent financial year or furnishing of the relevant annual return, whichever is earlier. In fact, not only is registration a pre-requisite (see, 'registered taxable person' shall be entitled to claim credit) but filing of return under section 39 is also a requirement. Input tax credit is a right that does not 'vest' until the last of conditions in section 16(2) are fulfilled. Until then, this right i.e., input tax credit is *inchoate* (or incomplete or in-formation) and not a vested right. Rights that are not yet vested can lapse by limitation unless effective steps to actualize those rights are taken by the person. And once the right stands vested, it becomes indefeasible except by operation of subsequent inherent conditions. In other words, input tax credit which is a right in law of the taxable person is not fully mature and is not available to the taxable person until all pre-conditions (steps to actualize available rights) have been taken. Section 16(2) lays down these steps that can be taken immediately or in course of time. And once all these steps are taken then the right i.e 'available' becomes a right that can be 'availed'. After the credit stands availed, it is available without any time limit. Section 18(4) provides a condition (known at the time of availing credit) that this credit will be reversed if the outward supplies become exempted. Other than this situation, the credit availed is permanently available to the taxable person. Now, in a situation where the credit that is 'available' is somehow delayed and 'not availed', it would still be available but not beyond the limitation prescribed in Section 16(4). Once the limitation prescribed in section 16(4) sets in, the credit which is 'not availed' by virtue of the limitation prescribed is proper in view of the

principle of reaching finality in respect of all 'available' credits that may 'not' be intended to be availed. Therefore in case of doubts one can avail the credit and then reverse under protest under intimation to revenue. This would ensure that the time limitation would not be the reason for non availment once clarity emerges from Courts.

Section 16(4) provides for time limit for availment of credit for Invoices and Debit Notes. Bill of Entry is not mentioned in Section 16(4) and hence it appears that there is no time limit for availment of credit in case of Bill of Entry. However, Table 8 of Form GSTR 9 (Annual Return format) suggests that credit related to bill of entry not availed within the due date will lapse.

It would be important to note that the due date for availing credit on debit notes is linked to the financial year to which invoice relating to such debit note pertains to and not the financial year in which the debit note has been issued.

Illustration

Document Type	Document Date	Due date for availing credit*
Invoice	05.07.2018	Returns for the month of September 2019
Debit Note	05.07.2018 (Debit Note relates to invoice raised on 05.03.2018)	Returns for the month of September 2018
Debit Note	05.12.2018 (Debit Note relates to invoice raised on 05.03.2018)	Returns for the month of September 2018 – Effectively, credit cannot be availed for debit notes issued after 6 months from the end of the financial year to which the invoice pertains to, though there is no time limit for issuance of Debit Note in Section 34 (unlike the time limit prescribed for Credit Notes under the said Section)

* assumed that Annual Returns have been filed after the filing of the returns for the month of September

- (f) **Deemed receipt of goods:** Section 16 permits a registered person to avail credit only after he has received the said goods or services or both. However, in case of bill to-ship to transactions (including where such goods are sent for job work), by which the registered person instructs his supplier to ship the goods to another person on his behalf, the date of receipt of goods by such another person shall be deemed to be the date of receipt of goods by the said registered person.

Therefore what exactly does 'received' mean in this context? Does it refer to actual receipt of goods at factory premises or even constructive receipt of goods would

suffice? Broadly, receipt of goods may be said to be complete when goods have been supplied as per the recipient's instructions and the supplier is discharged from any further liability on such goods. The delivery must be complete in all respects to the utmost satisfaction of the recipient. The point of acceptance in cases of pre requisite of quality control may have to be clear.

For example, an interesting scenario may be encountered when goods imported by a registered person are supplied directly to his customers in India from the port without bringing such imported goods (physically) to his factory premises. Would the importer still be entitled to ITC of IGST paid on imported goods although such goods were never received at his factory premises? The answer is 'Yes'. The importer, after fulfilling all the import formalities is deemed to have received the goods and thus, eligible to avail input tax credit of IGST paid on imports.

This scenario, i.e. in bill-to-ship-to model, where it is amended to include services also which deemed that goods are provided by recipient when the supplier delivers the goods to any other person on the direction of and on account the recipient shall be applicable in case of such services also. However, please note that this fiction for delivery of goods or services is not an attempt at encroaching upon the Place of Supply provisions of IGST Act but merely to satisfy the conditions for availment of credit in certain cases where someone else collects goods or enjoys services.

- (g) **Goods received in instalments:** If goods are received in instalments against a single invoice, credit can be availed upon receipt of last instalment of goods.

Illustration – A consignment of coal is to be dispatched from Kolkata to Mumbai using five trucks. An invoice was issued to the recipient on March 30, 2018. Four trucks reached the claimant by March 30, 2018 but the truck carrying the final lot of the consignment reached the recipient only on April 2, 2018. In this case, input tax credit for the entire consignment can be availed only in the month of April 2018.

- (h) **Receipt of Services:** The recipient can claim credit only upon receipt of services except a situation mentioned in Explanation to Section 16(2)(b). In the commercial world, while it is easy to demonstrate receipt of goods (by way of physical stock, e-way bill, GRN etc), the same is not to be in case of services which is an intangible in nature. Determination of actual receipt of services could be a formidable task especially when the contracting period for provision of service extends beyond a tax period but consideration is received in advance. .

Explanation to Section 16(2)(b) has been amended to include services. It has been stated that the registered person will be deemed to have received the services where the services are provided by the supplier to any person on direction of and on account of such registered person.

The person receiving any services may be different from the person who is liable to make the payment as the recipient under the law. The definition of recipient under the GST law has been defined to mean the person liable to make the payment. However, there are multiple cases where the payment is made by a particular person but the services are received by another person. In such a situation, the person liable to make the payment will be deemed to have received the services.

For instance, X is providing advisory services to Z for which the payment is agreed to be made by Y. In this situation, Y will be deemed to have received the services as per the new deeming fiction in the Explanation to Section 16(2). Thereby, Y will be allowed to avail input tax credit even though he is not in actual receipt of the services.

- (i) **Failure to pay to supplier of goods or service or both, the value of supply and tax thereon:** Where the recipient of goods or services or both have failed to pay the supplier within 180 days from date of invoice, input tax credit availed, in proportion to such unpaid consideration shall be added to the recipient's output tax liability along with interest as may be applicable. Such non-payment of the value of invoice must be disclosed in FORM-GSTR 2 filed for the month immediately following the expiry of 180 days from the date of issue of invoice. However, such input tax credit may be reclaimed as and when the unpaid amount (including taxes) is subsequently paid.

One may note that this condition shall not apply to supplies that are liable to tax under reverse charge and supplies made without consideration as specified in Schedule I. Conspicuous by its absence within this *carved out* provision is the import of goods. While reverse charge is excluded from the condition of having to make payment within 180 days, GST paid on import of goods does not fall within the ambit of reverse charge under section 9(3) or 9(4) of the CGST Act or Section 5(3) or Section 5(4) of the IGST Act although IGST paid on import of goods is akin to reverse charge. The question that now arises is - whether there can be reverse charge liability other than under section 9(3) and 9(4). The definition in section 2(98) does not permit such extended application. The privilege to prescribe pre-conditions for vesting of right to input tax credit belongs to section 16 and therefore, there is no other provision from where any overriding right to claim credit on goods imports may be borrowed or imputed. On the other hand, IGST paid under reverse charge on import of services is covered under Section 5(3) of the IGST Act as a result of which an importer of service would be entitled to credit of IGST paid even if the service provider remains unpaid beyond the said period of 180 days. Based on the above reasoning, credit of taxes paid on import of goods will not be available if the payment of value of goods is not made within 180 days. An alternative argument that is possible to take up is that the person who avails the credit is required to pay the value of supplies within 180 days from the date of issue of invoice. The term invoice has been defined to mean invoice raised under Section 31 and Section 31 provides that invoice can be issued by a registered person. Since the vendor outside India is not registered in India, the invoice raised by him is not an invoice in terms of

Section 31 and hence the criteria of 180 days is not applicable even in case of import of goods since the 'invoice' as per GST Laws is missing in this transaction.

One may however wonder the need for such a provision under the GST law, given the fact that payment of consideration is a private arrangement between the parties to the contract. The Government is needlessly meddling with contractual payment terms by dangling the sword of ITC reversal over the neck of the recipient of supply. The fact that the Government receives its tax when time of supply is triggered irrespective of when consideration is actually paid, adequately protects the interest of revenue thus failing to justify the need for such a provision.

It would be relevant to note that Section 15 of the CGST Act deals with valuation of supplies and provides for addition in the value of supply in case the price is not sole consideration or if the transacting parties are related. Such addition is made for GST purposes (to arrive at the tax payable) but commercially, such amount is neither recorded in the books nor paid by the transacting parties and hence in all such cases where additions are made to the value of supply, the recipient will be denied the credit since he does not make payment to the extent of such additions. The CGST Rules have accordingly been amended wef June 13, 2018 to provide that such additions made under Section 15(2)(b) will be deemed to have been paid by the recipient to the supplier.

- (j) **Capital goods on which depreciation is claimed:** Input tax credit shall not be allowed on the tax component of the cost of capital goods and plant and machinery if depreciation on such tax component has been claimed under the provisions of the Income Tax Act, 1961.

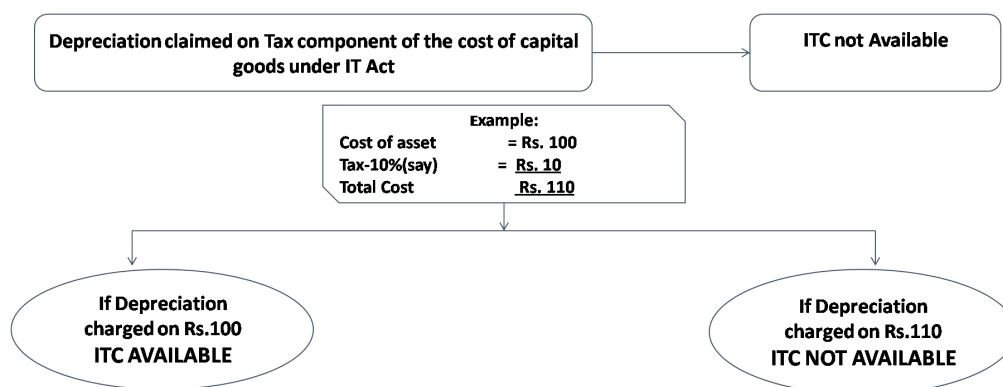

There may however, be instances where an assessee is unable to avail input tax credit on capital goods for various reasons, say for example, the department has objected to it. In such cases, assessee may decide to capitalize the tax component and avail depreciation on tax component also. Whenever the dispute relating to eligibility of input tax credit on capital goods is resolved, assessee may avail Input Tax Credit and correspondingly reverse the depreciation claimed under Income Tax Act, 1961 on tax

component. Similar provisions existed under CENVAT Credit Rules and the Hon'ble Gujarat High Court in the case Genus Electrotech Limited reported in 2013 (296) ELT 175 (Guj.) held that after reversal of entry for depreciation, assessee could avail credit. The ratio of this decision under the CENVAT Credit Rules, 2004 will equally hold good under the GST law since the provisions are similar. Although, there was no time limit for availing tax credit on capital goods under the CENVAT Credit Rules, 2004, under the GST law, credit cannot be availed after the due date of filing the returns for the month of September following the end of the financial year or the date of filing the annual return, whichever is earlier. It would be worthwhile to note that Rule 37(4) which provides for re-availing of input tax credit for an unrestricted period is applicable only in respect of ITC reversed earlier for non-payment of consideration to the supplier within 180 days and not for re-claim of ITC on account of reversal of depreciation as discussed above.

It may be interesting to note that Section 16(3) states that input tax credit shall not be allowed in cases where depreciation has been claimed on "the tax component of the cost of capital goods **and plant and machinery** under the provisions of the Income-tax Act, 1961." The use of the words plant and machinery in addition to 'capital goods' requires special attention. Capital Goods have been defined to mean goods used or intended to be used in the course or furtherance of business, the value of which has been capitalised in the books of account. Going by the above definition, 'Plant and machinery' in respect of which depreciation is to be claimed would *per se* fall within the ambit of capital goods as defined above. This special mention of 'plant and machinery' in addition to capital goods may be interpreted to mean that merely charging the value of plant and machinery (including the tax component thereof) to the Profit and Loss account could invalidate the claim of the registered person to input tax credit even though the asset (i.e., Plant and Machinery) has not been capitalised. The intention should be that what is not "revenue" in nature only can be capitalised and therefore whatever is not capitalised would be eligible. It appears that this contentious issue would only stand resolved over time.

In summary, among others the following facts are crucial for availment of Input tax credit:

- (a) The claimant should be registered under the GST Law to avail the input tax credit (except for certain exceptions covered under Section 18)
- (b) The goods and/ or services must be used "by him" in the course or furtherance "of his" business.
- (c) Possession of original tax Invoice/Supplementary Invoice/ Debit note/ ISD invoice/ Bill of Entry and other related documents is a must.
- (d) The said document must contain all the particulars prescribed / specified in Rule 46 of Central Goods and Service Tax Rules, 2017 relating to a Tax Invoice. It may be noted that the Tax Invoice or such other document can contain additional details other than those prescribed but NO LESS. For details of invoice, see Chapter VI of the CGST Rules. This requirement has been relaxed wef September 4, 2018. The registered person can avail input tax credit if the documents contain the following minimum details

- a. Amount of tax charged
 - b. Description of goods or services
 - c. Total value of supply of goods or services or both
 - d. GSTIN of the supplier and recipient
 - e. Place of supply in case of inter-State supply
- (e) Supplier of goods and/ or services must upload the details of such documents in the common portal i.e. GSTN. Subject to section 41 and 43A being claim of ITC and provisional acceptance thereof, the supplier must have remitted the tax charged on such supplies. The new return filing mechanism (Section 43A) may allow taking of input tax credit to the recipient in certain situations and subject to certain conditions even if payment of tax is not made by the supplier. So, payment of tax by the supplier has been made subject to the procedure in the new return filing mechanism which is yet to be notified.

CGST Amendment Act, 2017

Section 43A has been introduced to give effect to the revised return filing and credit availment mechanism. Currently, availment of credit is subject to Section 41 (provisional acceptance of credit) which is now being linked to revised return filing process i.e. Section 43A

- (f) Vesting condition for claiming input tax credit is the return u/s 39 and not the supply *per se*.
- (g) The claimant should have received the goods / services. Input tax credit in case of supplies in installment, would be on receipt of last installment of goods.
- (h) The law casts an obligation on the recipient of supply availing credit to effect payment to the supplier within a period of 180 days from the date of invoice. If such payment is not effected/ partially effected by the recipient to the supplier, Rule 37 obligates reversal/ proportionate reversal of input tax credit so availed leading to consequential levy of tax and interest.
- Proviso to section 16(2) provides that the taxable person shall be entitled to avail input tax credit after making payment of the amount towards value of supply of goods or services or both along with tax payable thereon. Further, Rule 37(4) provides that the time limit specified under section 16(4) shall not be applicable for such recredit.
- (i) Claim of depreciation on the GST component disqualifies a recipient of Capital goods and plant and machinery from availment of input tax credit.
- (j) ITC cannot be availed after the due date of filing the return for September month of the next financial year or on furnishing the Annual Return whichever is earlier.
- (k) No registered person is permitted to avail any input tax credit pursuant to an order of demand on account of fraud, willful misstatement, or suppression of fact.

Note: The last point is important as many of the cases in a routine manner the show cause notice would invoke these mala fide intentions and if not contested, the ITC would not be available to the receiver even if otherwise eligible.

16.3 Issues and Concerns

- (i) A consignment of coal is to be dispatched from Kolkata to Mumbai through five trucks for which the invoice was sent along with the first truck. Four trucks reached the claimant by March 30, 2018 but the truck carrying the final lot of the consignment falls down a gorge and is never received. Would this deny the input tax credit that should have otherwise been available on coal received on the first four lots? The answer is 'No'. The recipient in Mumbai needs to obtain a credit note from the supplier in Kolkata in respect of that lot which would never be received and accordingly avail ITC relating to the coal received at the business premises.
- (ii) Section 16 allows a recipient of supply to avail credit only when he has received the goods or services or both. For example, in an Annual Maintenance Contracts for machines entered into on November 1st, 2017, the supplier is under an obligation to render services arising over a period of 12 months (ending 31st October, 2018) but in respect of which an invoice is raised and consideration is received on the date of entering into the agreement i.e 1st November 2017 in this case. In such cases, the fate of input tax credit contained in the said invoice is left hanging in the balance considering the fact that input tax credit in respect of an invoice received during the year cannot be claimed after the due date for filing the return for the month of September of the succeeding year. In the given case, the receipt of service is said to be completed (i.e., AMC period ends) on October 31st, 2018, while the time limit for claiming credit is October 20th, 2018. Possible solution to overcome this situation could be to convert the AMC into Monthly / Quarterly Maintenance Contracts, if agreeable to the supplier. Alternatively, could it be interpreted that an AMC, is primarily an assurance which is received on the date of entering into the AMC and what follows is only a continuing obligation of the supplier and hence the service may be deemed to have been received on the date of commencement of the AMC. The above issue also arises in case of an insurance contract. It is possible for one to interpret or read down the law in such cases since every business operates on a concept of going concern. These issues would most certainly be put to test in the times to come.
- (iii) In case of a recipient who has reversed credit on account of non-payment of consideration within 180 days, can he avail credit in instalments as and when the payment is made to the supplier or should he reclaim the credit only when the entire amount including taxes has been paid to the supplier. Given that the third proviso to Section 16(2)(d) allows re-availment of credit on payment of 'the amount towards the value of supply of goods or services or both' and not 'an amount', reading strictly it may be construed that the entire amount would have to be paid for re-availment of credit earlier reversed. Consideration paid which is non-monetary form is also a consideration and for the scheme to work one needs to read harmoniously. Some experts argue that

the expression 'the amount towards the value of supply of goods or services or both' must be necessarily construed that it imply "whole of the value of supply". It may also be possible to understand that if the terms of payments envisage payment in part even after a period of 180 days that such proportionate could be availed from time to time depending on the amount of payment. It is a common practice that some deductions are there in the invoice without GST being deducted. Then can it be said that the whole consideration has not been paid and credit denied until the whole amount with taxes paid? The credit should be available for part payments, value deductions by customer without impacting the GST as well as non-monetary payments. These issues may be put to test in the days to come.

16.4 Comparative review

Aspect	Credit under erstwhile system	Input tax credit under GST
Definition of "capital goods"	Defined in Cenvat Credit Rules	Comparatively wider definition.
Definition of "input"	Defined in Cenvat credit Rules having inclusion and exclusion limbs.	Exhaustive definition and does not contain inclusion or exclusion limb.
Definition of "input services"	Defined in Cenvat credit Rules which has inclusion and exclusion limb.	Exhaustive definition and does not contain inclusion or exclusion limb.
Electronic credit ledger	Similar to CENVAT credit register maintained in Form RG23A	Electronic credit ledger required to be maintained for crediting and utilising input tax credit

While CENVAT Credit Rules identified three components for credit availment, namely Input, Input Services and Capital Goods, the GST law allows input tax credit on goods and services with goods being further classified into inputs and capital goods in certain cases.

Statutory Provisions- Effective from 1st July, 2017 to 31st January, 2019

17. Apportionment of credit and blocked credit

- (1) *Where the goods or services or both are used by the registered person partly for the purpose of any business and partly for other purposes, the amount of credit shall be restricted to so much of the input tax as is attributable to the purposes of his business.*
- (2) *Where the goods or services or both are used by the registered person partly for effecting taxable supplies including zero-rated supplies under this Act or under the Integrated Goods and Services Tax Act, and partly for effecting exempt supplies*

under the said Acts, the amount of credit shall be restricted to so much of the input tax as is attributable to the said taxable supplies including zero-rated supplies.

(3) *The value of exempt supply under sub-section (2) shall be such as may be prescribed, and shall include supplies on which the recipient is liable to pay tax on reverse charge basis, transactions in securities, sale of land and, subject to clause (b) of paragraph 5 of Schedule II, sale of building.*

(4) *A banking company or a financial institution including a non-banking financial company, engaged in supplying services by way of accepting deposits, extending loans or advances shall have the option to either comply with the provisions of sub-section (2), or avail of, every month, an amount equal to fifty per cent of the eligible input tax credit on inputs, capital goods and input services in that month and the rest shall lapse.*

Provided that the option once exercised shall not be withdrawn during the remaining part of the financial year.

Provided further that the restriction of fifty per cent. shall not apply to the tax paid on supplies made by one registered person to another registered person having the same Permanent Account Number

(5) *Notwithstanding anything contained in sub-section (1) of section 16 and subsection (1) of section 18, input tax credit shall not be available in respect of the following namely:*

(a) *motor vehicles and other conveyances except when they are used—*

(i) *for making the following taxable supplies, namely:—*

(A) *further supply of such vehicles or conveyances ; or*

(B) *transportation of passengers; or*

(C) *imparting training on driving, flying, navigating such vehicles or conveyances;*

(ii) *for transportation of goods;*

(b) *the following supply of goods or services or both—*

(i) *food and beverages, outdoor catering, beauty treatment, health services, cosmetic and plastic surgery except where an inward supply of goods or services or both of a particular category is used by a registered person for making an outward taxable supply of the same category of goods or services or both or as an element of a taxable composite or mixed supply;*

(ii) *membership of a club, health and fitness centre;*

(iii) *rent-a-cab, life insurance and health insurance except where—*

(A) *the Government notifies the services which are obligatory for an*

employer to provide to its employees under any law for the time being in force; or

(B) such inward supply of goods or services or both of a particular category is used by a registered person for making an outward taxable supply of the same category of goods or services or both or as part of a taxable composite or mixed supply; and

(iv) travel benefits extended to employees on vacation such as leave or home travel concession;

(c) works contract services when supplied for construction of an immovable property (other than plant and machinery) except where it is an input service for further supply of works contract service;

(d) goods or services or both received by a taxable person for construction of an immovable property (other than plant and machinery) on his own account, including when such goods or services or both are used in the course or furtherance of business;

Explanation. - For the purpose of clause (c) and (d), the expression "construction" includes re-construction, renovation, additions or alterations or repairs, to the extent of capitalization, to the said immovable property.

(e) goods or services or both on which tax has been paid under section 10;

(f) goods or services or both received by a non-resident taxable person except on goods imported by him;

(g) goods or services or both used for personal consumption;

(h) goods lost, stolen, destroyed, written off or disposed of by way of gift or free samples; and

(i) any tax paid in accordance with the provisions of sections 74, 129 and 130.

(6) The Government may prescribe the manner in which the credit referred to in sub-sections (1) and (2) may be attributed.

Explanation. For the purposes of this Chapter and Chapter VI, the expression 'plant and machinery' means apparatus, equipment and machinery fixed to earth by foundation or structural support that are used for making outward supply of goods or services or both and includes such foundation and structural supports but excludes

(i) land, building or any other civil structures,

(ii) telecommunication towers; and

(iii) pipelines laid outside the factory premises

Statutory Provisions- Effective from 1st February 2019 vide The Central Goods & Services Tax Amendment Act,2018

17. Apportionment of credit and blocked credit

(1) *Where the goods or services or both are used by the registered person partly for the purpose of any business and partly for other purposes, the amount of credit shall be restricted to so much of the input tax as is attributable to the purposes of his business.*

(2) *Where the goods or services or both are used by the registered person partly for effecting taxable supplies including zero-rated supplies under this Act or under the Integrated Goods and Services Tax Act, and partly for effecting exempt supplies under the said Acts, the amount of credit shall be restricted to so much of the input tax as is attributable to the said taxable supplies including zero-rated supplies.*

(3) *The value of exempt supply under sub-section (2) shall be such as may be prescribed, and shall include supplies on which the recipient is liable to pay tax on reverse charge basis, transactions in securities, sale of land and, subject to clause (b) of paragraph 5 of Schedule II, sale of building.*

Explanation.—For the purposes of this sub-section, the expression “value of exempt supply” shall not include the value of activities or transactions specified in Schedule III, except those specified in paragraph 5 of the said Schedule]

(4) *A banking company or a financial institution including a non-banking financial company, engaged in supplying services by way of accepting deposits, extending loans or advances shall have the option to either comply with the provisions of sub-section (2), or avail of, every month, an amount equal to fifty per cent of the eligible input tax credit on inputs, capital goods and input services in that month and the rest shall lapse.*

Provided that the option once exercised shall not be withdrawn during the remaining part of the financial year.

Provided further that the restriction of fifty per cent. shall not apply to the tax paid on supplies made by one registered person to another registered person having the same Permanent Account Number

(5) *Notwithstanding anything contained in sub-section (1) of section 16 and subsection (1) of section 18, input tax credit shall not be available in respect of the following namely:*

(c) *motor vehicles for transportation of persons having approved seating capacity of not more than thirteen persons (including the driver), except when they are used for making the following taxable supplies, namely:—*

(A) *further supply of such motor vehicles; or*

- (B) *transportation of passengers; or*
- (C) *imparting training on driving such motor vehicles;*
- (aa) *vessels and aircraft except when they are used—*
- (i) *for making the following taxable supplies, namely:—*
- (A) *further supply of such vessels or aircraft; or*
- (B) *transportation of passengers; or*
- (C) *imparting training on navigating such vessels; or*
- (D) *imparting training on flying such aircraft;*
- (ii) *for transportation of goods;*
- (ab) *services of general insurance, servicing, repair and maintenance in so far as they relate to motor vehicles, vessels or aircraft referred to in clause (a) or clause (aa):*
- Provided that the input tax credit in respect of such services shall be available—*
- (i) *where the motor vehicles, vessels or aircraft referred to in clause (a) or clause (aa) are used for the purposes specified therein;*
- (ii) *where received by a taxable person engaged—*
- (I) *in the manufacture of such motor vehicles, vessels or aircraft; or*
- (II) *in the supply of general insurance services in respect of such motor vehicles, vessels or aircraft insured by him;*
- (d) *the following supply of goods or services or both—*
- (i) *food and beverages, outdoor catering, beauty treatment, health services, cosmetic and plastic surgery, leasing, renting or hiring of motor vehicles, vessels or aircraft referred to in clause (a) or clause (aa) except when used for the purposes specified therein, life insurance and health insurance:*
- Provided that the input tax credit in respect of such goods or services or both shall be available where an inward supply of such goods or services or both is used by a registered person for making an outward taxable supply of the same category of goods or services or both or as an element of a taxable composite or mixed supply;*
- (ii) *membership of a club, health and fitness centre; and*
- (iii) *travel benefits extended to employees on vacation such as leave or home travel concession.*
- Provided that the input tax credit in respect of such goods or services or both shall be available, where it is obligatory for an employer to provide to its employees under any law for the time being in force.*

(c) works contract services when supplied for construction of immovable property, (other than plant and machinery), except where it is an input service for further supply of works contract service;

(d) goods or services or both received by a taxable person for construction of an immovable property (other than plant and machinery) on his own account, including when such goods or services or both are used in the course or furtherance of business;

Explanation. - For the purpose of clause (c) and (d), the expression "construction" includes re-construction, renovation, additions or alterations or repairs, to the extent of capitalization, to the said immovable property.

(e) goods or services or both on which tax has been paid under section 10;

(f) goods or services or both received by a non-resident taxable person except on goods imported by him;

(g) goods or services or both used for personal consumption;

(h) goods lost, stolen, destroyed, written off or disposed of by way of gift or free samples; and

(i) any tax paid in accordance with the provisions of sections 74, 129 and 130.

(6) The Government may prescribe the manner in which the credit referred to in sub-sections (1) and (2) may be attributed.

Explanation. For the purposes of this Chapter and Chapter VI, the expression 'plant and machinery' means apparatus, equipment and machinery fixed to earth by foundation or structural support that are used for making outward supply of goods or services or both and includes such foundation and structural supports but excludes

(i) land, building or any other civil structures,

(ii) telecommunication towers; and

(iii) pipelines laid outside the factory premises

Extract of the CGST Rules, 2017

38. Claim of credit by a banking company or a financial institution.

A banking company or a financial institution, including a non-banking financial company, engaged in the supply of services by way of accepting deposits or extending loans or advances that chooses not to comply with the provisions of sub-section (2) of section 17, in accordance with the option permitted under sub-section (4) of that section, shall follow the following procedure, namely,-

(a) the said company or institution shall not avail the credit of,-

- (i) the tax paid on inputs and input services that are used for non-business purposes; and
 - (ii) the credit attributable to the supplies specified in sub-section (5) of section 17, in FORM GSTR-2;
- (b) the said company or institution shall avail the credit of tax paid on inputs and input services referred to in the second proviso to sub-section (4) of section 17 and not covered under clause (a);
- (c) fifty per cent. of the remaining amount of input tax shall be the input tax credit admissible to the company or the institution and shall be furnished in FORM GSTR- 2;
- (d) the amount referred to in clauses (b) and (c) shall, subject to the provisions of sections 41, 42 and 43, be credited to the electronic credit ledger of the said company or the institution.

42. Manner of determination of input tax credit in respect of inputs or input services and reversal thereof

- 1) The input tax credit in respect of inputs or input services, which attract the provisions of sub-section (1) or sub-section (2) of section 17, being partly used for the purposes of business and partly for other purposes, or partly used for effecting taxable supplies including zero rated supplies and partly for effecting exempt supplies, shall be attributed to the purposes of business or for effecting taxable supplies in the following manner, namely,-
- a) the total input tax involved on inputs and input services in a tax period, be denoted as 'T';
 - b) the amount of input tax, out of 'T', attributable to inputs and input services intended to be used exclusively for the purposes other than business, be denoted as 'T1';
 - c) the amount of input tax, out of 'T', attributable to inputs and input services intended to be used exclusively for effecting exempt supplies, be denoted as 'T2';
 - d) the amount of input tax, out of 'T', in respect of inputs and input services on which credit is not available under sub-section (5) of section 17, be denoted as 'T3';
 - e) the amount of input tax credit credited to the electronic credit ledger of registered person, be denoted as 'C1' and calculated as-

$$C1 = T - (T1 + T2 + T3);$$
 - f) the amount of input tax credit attributable to inputs and input services intended to be used exclusively for effecting supplies other than exempted but including zero rated supplies, be denoted as 'T4';
 - g) 'T1', 'T2', 'T3' and 'T4' shall be determined and declared by the registered person at the invoice level in FORM GSTR-2;

- h) *input tax credit left after attribution of input tax credit under clause (g) shall be called common credit, be denoted as 'C2' and calculated as:*

$$C2 = C1 - T4;$$

- i) *the amount of input tax credit attributable towards exempt supplies, be denoted as 'D1' and calculated as*

$$D1 = (E \div F) \times C2 \text{ where,}$$

'E' is the aggregate value of exempt supplies during the tax period, and

'F' is the total turnover in the State of the registered person during the tax period:

Provided that where the registered person does not have any turnover during the said tax period or the aforesaid information is not available, the value of 'E/F' shall be calculated by taking values of 'E' and 'F' of the last tax period for which the details of such turnover are available, previous to the month during which the said value of 'E/F' is to be calculated;

Explanation: For the purposes of this clause, it is hereby clarified that the aggregate value of exempt supplies and the total turnover shall exclude the amount of any duty or tax levied under entry 84 of List I of the Seventh Schedule to the Constitution and entry 51 and 54 of List II of the said Schedule;

- j) *the amount of credit attributable to non-business purposes if common inputs and input services are used partly for business and partly for non-business purposes, be denoted as 'D2', and shall be equal to five per cent. of C2; and*
- k) *the remainder of the common credit shall be the eligible input tax credit attributed to the purposes of business and for effecting supplies other than exempted supplies but including zero rated supplies and shall be denoted as 'C3', where,-*

$$C3 = C2 - (D1 + D2);$$

- l) *the amount 'C3' shall be computed separately for input tax credit of central tax, State tax, Union territory tax and integrated tax;*
- m) *the amount equal to aggregate of 'D1' and 'D2' shall be added to the output tax liability of the registered person:*

Provided that where the amount of input tax relating to inputs or input services used partly for the purposes other than business and partly for effecting exempt supplies has been identified and segregated at the invoice level by the registered person, the same shall be included in 'T1' and 'T2' respectively, and the remaining amount of credit on such inputs or input services shall be included in 'T4'.

- 2) *The input tax credit determined under sub-rule (1) shall be calculated finally for the financial year before the due date for furnishing of the return for the month of September following the end of the financial year to which such credit relates, in the manner specified in the said sub-rule and-*

- a) where the aggregate of the amounts calculated finally in respect of 'D1' and 'D2' exceeds the aggregate of the amounts determined under sub-rule (1) in respect of 'D1' and 'D2', such excess shall be added to the output tax liability of the registered person in the month not later than the month of September following the end of the financial year to which such credit relates and the said person shall be liable to pay interest on the said excess amount at the rate specified in sub-section (1) of section 50 for the period starting from the first day of April of the succeeding financial year till the date of payment; or
- b) where the aggregate of the amounts determined under sub-rule (1) in respect of 'D1' and 'D2' exceeds the aggregate of the amounts calculated finally in respect of 'D1' and 'D2', such excess amount shall be claimed as credit by the registered person in his return for a month not later than the month of September following the end of the financial year to which such credit relates.

43. Manner of determination of input tax credit in respect of capital goods and reversal thereof in certain cases

1) Subject to the provisions of sub-section (3) of section 16, the input tax credit in respect of capital goods, which attract the provisions of sub-sections (1) and (2) of section 17, being partly used for the purposes of business and partly for other purposes, or partly used for effecting taxable supplies including zero rated supplies and partly for effecting exempt supplies, shall be attributed to the purposes of business or for effecting taxable supplies in the following manner, namely,-

- a) the amount of input tax in respect of capital goods used or intended to be used exclusively for non-business purposes or used or intended to be used exclusively for effecting exempt supplies shall be indicated in FORM GSTR-2 and shall not be credited to his electronic credit ledger;
- b) the amount of input tax in respect of capital goods used or intended to be used exclusively for effecting supplies other than exempted supplies but including zero rated supplies shall be indicated in FORM GSTR-2 and shall be credited to the electronic credit ledger;
- c) the amount of input tax in respect of capital goods not covered under clauses (a) and (b), denoted as 'A', shall be credited to the electronic credit ledger and the useful life of such goods shall be taken as five years from the date of the invoice for such goods:

Provided that where any capital goods earlier covered under clause (a) is subsequently covered under this clause, the value of 'A' shall be arrived at by reducing the input tax at the rate of five percentage points for every quarter or part thereof and the amount 'A' shall be credited to the electronic credit ledger;

Explanation.- An item of capital goods declared under clause (a) on its receipt shall not attract the provisions of sub-section (4) of section 18, if it is subsequently

covered under this clause.

- d) the aggregate of the amounts of 'A' credited to the electronic credit ledger under clause (c), to be denoted as 'Tc', shall be the common credit in respect of capital goods for a tax period:

Provided that where any capital goods earlier covered under clause (b) is subsequently covered under clause (c), the value of 'A' arrived at by reducing the input tax at the rate of five percentage points for every quarter or part thereof shall be added to the aggregate value 'Tc';

- e) the amount of input tax credit attributable to a tax period on common capital goods during their useful life, be denoted as 'Tm' and calculated as-

$$T_m = T_c \div 60$$

- f) the amount of input tax credit, at the beginning of a tax period, on all common capital goods whose useful life remains during the tax period, be denoted as 'Tr' and shall be the aggregate of 'Tm' for all such capital goods;
- g) the amount of common credit attributable towards exempted supplies, be denoted as 'Te', and calculated as-

$$T_e = (E \div F) \times T_r$$

where,

'E' is the aggregate value of exempt supplies, made, during the tax period,
and

'F' is the total turnover of the registered person during the tax period:

Provided that where the registered person does not have any turnover during the said tax period or the aforesaid information is not available, the value of 'E/F' shall be calculated by taking values of 'E' and 'F' of the last tax period for which the details of such turnover are available, previous to the month during which the said value of 'E/F' is to be calculated;

Explanation.- For the purposes of this clause, it is hereby clarified that the aggregate value of exempt supplies and the total turnover shall exclude the amount of any duty or tax levied under entry 84 of List I of the Seventh Schedule to the Constitution and entry 51 and 54 of List II of the said Schedule;

- h) the amount 'Te' along with the applicable interest shall, during every tax period of the useful life of the concerned capital goods, be added to the output tax liability of the person making such claim of credit.

- 2) The amount 'Te' shall be computed separately for central tax, State tax, Union territory tax and integrated tax.

Explanation: -For the purposes of rule 42 and this rule, it is hereby clarified that the aggregate value of exempt supplies shall exclude: -

- a) *the value of supply of services specified in the notification of the Government of India in the Ministry of Finance, Department of Revenue No. 42/2017-Integrated Tax (Rate), dated the 27th October, 2017 published in the Gazette of India, Extraordinary, Part II, Section 3, Sub-section (i), vide number GSR 1338(E) dated the 27th October, 2017;*
- b) *the value of services by way of accepting deposits, extending loans or advances in so far as the consideration is represented by way of interest or discount, except in case of a banking company or a financial institution including a non-banking financial company, engaged in supplying services by way of accepting deposits, extending loans or advances; and*
- c) *the value of supply of services by way of transportation of goods by a vessel from the customs station of clearance in India to a place outside India.*

Relevant circulars, notifications, clarifications issued by Government

- Chapter Nineteen of the compilation of the GST Flyers as issued by the CBIC on 'Input Tax Credit Mechanism in GST'

Related Provisions of the CGST Statute

Section or Rule	Description
Section 2(47)	Definition of 'Exempt Supply'
Section 2(119)	Definition of 'Works Contract'
Section 16	Eligibility and conditions for taking input tax credit
Section 18	Availability of credit in special circumstances
Section 74	Determination of tax not paid or short paid or erroneously refunded or input tax credit wrongly availed or utilised by reason of fraud or any wilful misstatement or suppression of facts.
Section 129	Detention, seizure and release of goods and conveyances in transit
Section 130	Confiscation of goods or conveyances and levy of penalty
Schedule II	Activities to be treated as supply of goods or supply of services
Rule 45	Conditions and restrictions in respect of inputs and capital goods sent to the job worker
Section 16 of IGST Act	Zero Rated Supply

17.1 Introduction

The input tax credit eligibility is based on the fact as to whether the goods or services or both are used for taxable supplies or exempt supplies. Where the goods or service or both are used for both taxable and exempted supplies, only proportionate credit is allowed to a registered person, Further, this section provides for a list of supplies that are ineligible for input tax credit.

17.2 Analysis

(a) Proportionate credit:

ITC based on usage in business

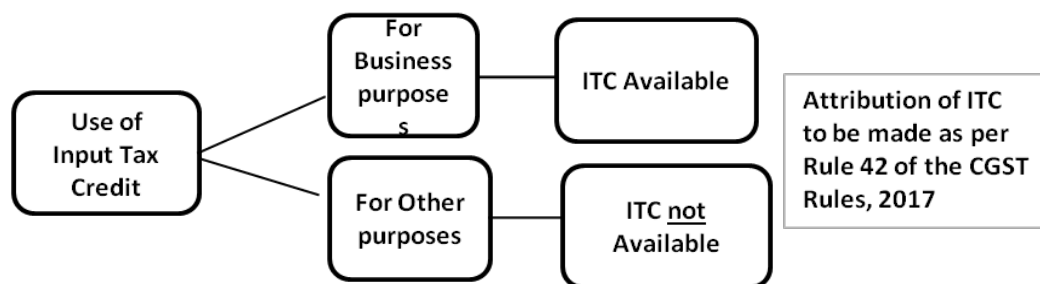

ITC based on use of Inputs

ITC on the Basis of use of Inputs

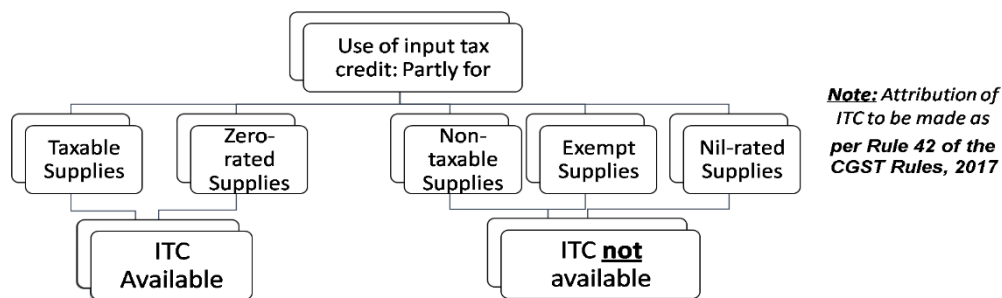

Alternative to apportionment between taxable & exempt supplies in case of **banking companies & financial institutions**:

- **Yearly option** to avail a standard rate of 50% of eligible ITC on inputs, capital goods and input services on a **monthly basis**

(b) **Definition of 'exempt supply'**: It is very interesting to note that although an exempt supply is defined in section 2(47), section 17(3) read with explanation (2) in rule 45 for purposes of input tax credit reversal includes the following transactions as well:

- tax paid under reverse charge,
- transaction in securities,

- sale of land and sale of building subject to clause (b) of Paragraph 5 of Schedule II.

Thus, in a way, exempt supply for the purpose of section 17(3) means all such transactions that come within the sweep and ambit of section 2(47) and such other transactions listed in section 17(3) – is this permissible under law ?

Please note that the value of supplies in respect of which the outward supplier is not liable to pay tax but the recipient is made liable to pay tax under Sections 9(3) and 5(3) of the CGST and IGST Act respectively, would be regarded as 'exempt supplies' for the limited purpose of determining net available input tax credit. Doubts have been raised whether such supplies should be included as exempt supplies by the recipient who pays the tax under reverse charge. In this context, it would be relevant to note that Section 17(3) identifies supplies attracting reverse charge to be an exempt supply in the hands of the supplier effecting such supplies and not in the hands of the recipient who avails such services liable under reverse charge.

Explanation added to Section 17(3) is an important amendment to allow assessee to avail full credit even if they are not paying GST if the activities or transactions are mentioned in Schedule III except sale of land and completed building.

For Eg. Sale of goods on high seas or merchant trading transactions will not entail any reversal of input tax credit as they have now been covered under Schedule III after the amendment.

CGST Amendment Act, 2018

An explanation has been added to Section 17(3) to provide that value of exempt supplies shall not include transactions listed under Schedule III (Transactions which are treated "neither as a supply of goods nor a supply of services") except sale of Land and Completed Building. Thus, no credit would be required to be reversed for engaging in transactions referred under Section Schedule III though no GST is paid on such transactions.

The above explanation will also cover two new entries which have been added to the said Schedule – Supply of Warehoused Goods before clearance for home consumption and Supply of Goods from one non-taxable territory to another without the goods entering India. No reversal of credit would be required for engaging in these transactions.

- (c) **Banking Company or financial institution including NBFC engaged in accepting deposits, extending loans or advances:** An option is made available to a Banking company or financial institution including NBFC engaged in accepting deposits, extending loans or advances that chooses not to comply with the provisions of sub-section (2) of section 17:

- (i) Refrain from availing input tax credit relating to 'non-business purposes' and those restricted u/s 17(5) – This needs to be reported in FORM-GSTR 2
- (ii) Avail full credit on inter-branch supply of services between distinct persons of the banking or NBFC company; and
- (iii) Avail 50% of 'all other' input tax credits. 'All other' credits refer to eligible input tax credit that would have been available u/s 16 before administering the restriction in this section.

(d) Ineligible Input Tax Credit – Input Tax Credit will not be available in respect of the following

This section commences with a non obstante clause "notwithstanding anything contained in sub section (1) of section 16 and sub section (1) of section 18". It clearly means that the provisions of section 17(5) overrides sections 16(1) and 18(1). Not satisfied with this restriction, the legislature uses the expression 'in respect of' appearing in section 17(5) which connotes a narrower meaning akin to "only".

Consider an illustration where input 'A' is converted into output 'B' (both being goods) and a certain quantity of output 'B' that are produced but not yet supplied are destroyed by fire. Now, is GST payable on output 'B' or is it sufficient, if input tax credit taken on input 'A' is reversed?. Destruction of a part of output 'B' does not satisfy the requirements of 'supply' and therefore, there is no question of payment of tax on the output that are destroyed by fire before they are supplied. This would have been the case under Central Excise law (as Central Excise Duty was payable on manufacture) but those principles do not find place in GST law. Under the GST laws, on destruction of output 'B', the only tax that remains to be paid is the proportionate credit availed on input 'A'. Recovery of input credit that was properly availed on 'A' used in the course or furtherance of business in the production of 'B' which was subsequently destroyed before being supplied renders the credit availed to fail the requirements of section 16(1). Credit is not an entitlement at the time of receipt of inputs but an entitlement on the condition of its participation in a taxable outward supply. It must be added here that, there is no question of reversal of input tax credit under clause (h) in respect of inputs forming part of normal (or even abnormal) wastage in the course of production of the output. Credit 'in respect of' inputs that fail to participate in a taxable outward supply are identified and recovered by this clause. Therefore, by this illustration, it becomes clear that the words 'in respect of' are not limited to the very articles that are disqualified from claim of input tax credit under this subsection but also credits 'in respect of' goods or services linked to the disqualified articles are also liable to be disqualified. The analysis of above provision in a pictorial form is summarised as follows:

Restrictions on ITC: Blocked credits under Sec 17(5)**(a) Motor Vehicles**

Note: Further, to come out of the restriction applicable to motor vehicles 'claiming' them to be for transportation of goods or transportation of passengers, registrations necessary under the motor vehicles' registration laws must also be in alignment with such a 'claim'. It would not suffice to merely claim motor vehicles which are duly registered for 'private use' to be used for transportation of goods or transportation of passengers. It may be a fact that a motor vehicle registered for private use, is in fact, used often for transportation of goods or transportation of passengers, it would still not escape the restriction because of the primary purpose of such a motor vehicle reported at the time of its registration.

Also note that rent-a-cab is a term that has been defined in Motor Vehicles Rules, 1989 and motor cab is defined in section 2(25) of the Motor Vehicles Act, 1988 to be limited to vehicles designed to transport 'less than 6' persons. Service tax law, however, expanded the meaning of 'cab' while imposing tax under the category of Rent-a-Cab Operator Services to include vehicles designed to seat more than 12 persons. In this section, rent-a-cab is not defined and it must be admitted to be an expression not of common usage. Now, the question arises as to whether the expansive meaning from the (now repealed) Finance Act, 1994 is to be borrowed or the meaning (now valid) Motor Vehicles Act/Rules is to be considered. It is a settled position of law that current law, would prevail over repealed law. As such, it would be limited to motor cabs designed to carry 'less than 6 persons'. Thus, input tax credit in respect of transport of persons in a bus or minivan (for more than 6 persons) would not be blocked and the restriction shall apply only in respect of cars used as cabs.

It would also be relevant to note that for availment of credit on motor vehicles used for transport of passengers, the vehicle should be used for making taxable outward supplies. On the other hand, credit on motor vehicles used for transport of goods, does not require taxable outward supplies to be effected. Hence, a company using a motor vehicle for site visit purposes may not be eligible to avail credit on such motor vehicle but a Company using a motor vehicle to transport goods from their warehouse to factory / site or from factory to customer location would be entitled to claim credit of taxes paid on such motor vehicle.

After effective date Clause (b) of Section 9 of CGST Amendment Act, 2018 replaces clause (a) of Section 17(5) regarding eligibility/ non-eligibility of input tax credit on vehicles is more specific. As per amended provisions, motor vehicles for transportation of persons having approved seating capacity of not more than thirteen person 13 persons (including the driver) are excluded from eligible input tax credit except motor vehicles are), Vessel and Aircraft if used for following specified purpose.:

- (a) Further supply of such vehicle or vessel or aircraft or
- (b) Transportation of passengers or
- (c) Imparting training on driving, flying, navigating, such vehicles or

- (d) Imparting training on navigating such vessels or
- (e) Imparting training on flying such aircraft

As per the amended provisions, ITC on motor vehicles with approved capacity of more than 13 persons (including the driver) shall be available. Further, credit of general insurance, servicing, repair and maintenance shall be available so far as it relates to motor vehicle, vessels or aircraft on which credit is available. Further, credit will also be available if the services are received by a taxable person engaged in manufacture of the motor vehicles or in supply of general insurance services in respect of motor vehicles, vessels or aircraft insured by him.

(b) Supply of goods and services being:

In the certain specified cases, credit is blocked unless they are used in making a further outward supply as such or as an element of a composite or mixed supply.

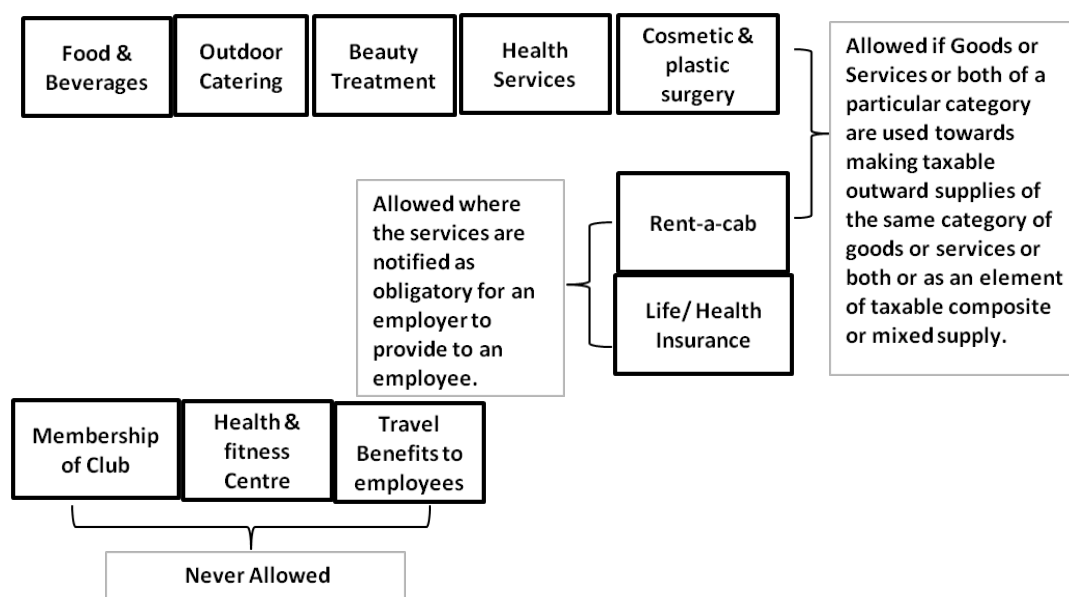

As per amended section 17(5), input tax credit of all above services shall be eligible if it is obligatory on the part of employer to provide the same to its employees under any law for the time being in force. For Eg Credit of GST paid on outdoor catering services used in factory may be allowed after effective date, as Factories Act made it compulsory to provide canteen services if factory has certain no of employees. Earlier, this credit was not allowed.

Note: Though credit is restricted in respect of the above supplies, credit would still be allowed if they are used for effecting further taxable supply of the same category; or as an element of a taxable composite or mixed supply. Often in a business scenario, it is extremely difficult to link up such inward supplies to taxable outward supplies. For instance – in a rent-a-cab

service – input tax credit would be allowed if the corresponding inward supply could be linked to an outward supply of the very same rent-a-cab service; but if rent-a-cab outward supply is provided free of cost then the question that arises is – whether input tax needs restriction or output supply is subject to valuation? Assume that in the very same example the rent-a-cab outward supply is provided by a hotel to its guest – say free drop to airport – what would be the position of input taxes ? The pertinent question would be whether it was for furtherance of business for which the obvious answer would be in affirmative as in business nothing is done for charity and the cost would have been included in the value of the other service or goods. Alternative views may arise due to the facility not being uniformly available to all guests. Readers are free to frame their views considering the circumstances.

It would not suffice to merely claim that these restricted supplies are used for further taxable supply in the absence of a clear link between the restricted inward supply and the taxable outward supply. Mere utilization of these restricted supplies for the benefit of the supplier in the course of an outward supply may validate availment of input tax credit on such restricted supplies.

Certain instances where the credits on aforementioned restricted categories can be attempted to be availed

Inward Supplies	Credit Eligibility
Food & Beverages or Outdoor Catering	<p>Corporate party organized by hiring an Event Manager. Event Manager is contracted to ensure all arrangements relating to food, guests, lighting, decoration, cab services for pick up and drop etc</p> <p>Event Manager uses the services of a caterer to serve food at the party and engages a rent-a-cab operator to pick-up and drop guests.</p> <p>(i) Credit to Event Manager for food and Rent-a-Cab services – Available since inward supplies have been used for making outward supplies</p> <p>(ii) Credit to Company – Available since they are availing composite supply of event management and not a standalone supply of various elements contained in organizing such event</p>
Renting or hiring of motor vehicles provided to Company for transport of female employees who work on night shift	Karnataka Shops and Establishment Regulations mandates every employer to ensure that cab facility is provided to female employees working during night shift. Any cab facility provided for transport of female employees is mandated by statute and credit of the same would be available to the employer.

Travel Benefits to Directors	Travel Benefits to employees have been specifically restricted from credit availment but nothing has been mentioned about the travel benefits extended to non-executive directors and hence the same should be available. Credits on transactions for “non business use” may not apply here since Company is accounting this as a business expenditure in their books of accounts.
------------------------------	--

Clause (b) of Section 9 of CGST Amendment Act, 2018 replaces clause (b) of Section 17(5) to bring out the following amendments:

1. Credit shall not be available for the supply of food and beverages, outdoor catering, beauty treatment, health services, cosmetic and plastic surgery, leasing, renting or hiring of motor vehicles, vessels or aircraft referred to in clause (a) or clause (aa) of Section 17(5) except when used for the purposes specified therein. In other words, renting or hiring of motor vehicles, vessels and aircraft are blocked only if the purchase of such motor vehicles, vehicles and aircrafts are blocked as per clause (a) of (aa). However, input tax credit in respect of such goods or services or both shall be available where an inward supply of such goods or services or both is used by a registered person for making an outward taxable supply of the same category of goods or services or both or as an element of a taxable composite or mixed supply.
2. Further, credit in respect of life insurance and health insurance will continue to be blocked.
3. ITC on membership of club, health and fitness centre will also be considered as blocked
4. Further, travel benefits extended to employees on vacation such as leave or home travel concession will also not be available.
5. The provisions have been amended so as to allow ITC in respect of goods or services or both specified above if it is made obligatory for an employer to provide such services under any law for the time being in force.
6. In all the above cases, the credit will be available if the goods or services are required to be provided by the employer through any obligation imposed under any law

Where steps are taken to include these inward supplies as an ‘element’ of an outward supply, then credit cannot be denied.

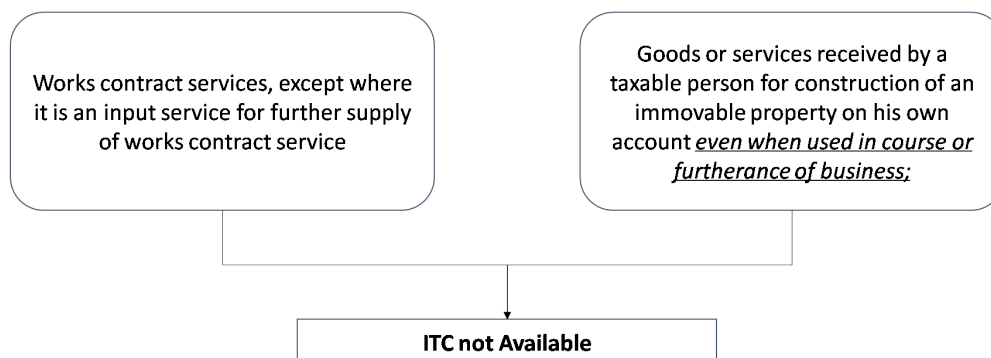
(c) Construction of Immovable Property (other than plant & machinery)

“Construction” includes re-construction, renovation, additions or alterations or repairs, to the extent of capitalization, to the said immovable property. Please note that ‘alterations’ and ‘repairs’ are also included in this definition if capitalized.

Note: Considering that ‘works contract services’ is not classified as a taxable outward supply in itself, the restriction would apply only in such of those cases where the corresponding inward supply of ‘works contract services’ is not used directly in a further taxable outward supply. Input tax credit attributable to ‘Works Contract Services’ (including on inward supply of goods or services) availed by builders / developers for providing outward supply of services, would be eligible for ITC. It is important to note that credit of GST paid on works contract services would be allowed only if the output supply is also works contract services.

In respect of inward supply of works contract resulting in immovable property for own use, the corresponding tax credits would be blocked if it is used “for” construction. Hence, costs directly related to construction would not enjoy any input tax credit, but costs which directly do not relate to construction would be entitled to credit.

Plant and machinery: means apparatus, equipment, machinery fixed to earth by foundation or structural support that are used for making outward supply of goods or services or both and includes such foundation and **structural** supports but excludes land, building or any other civil structures, telecommunication towers; and pipelines laid outside the factory premises. The definition of plant and machinery is also unique in including foundation and support which could be a works contract service for which credit is allowed but excludes ‘any other civil structure’. The intention appears to be put to rest the disputes in the past where foundation and structure which may include civil construction which are part of the plant and machinery would be eligible for credit. Specific exclusion like telecommunication towers may exclude some parts of other than the basic tower. These aspects may also be retested in time to come.

(d) Self-construction

Inward supply of goods or services for construction of an immovable property for ‘own use’ would also not be eligible for input tax credit. This restriction applies even when such

immovable property is used in the course or in furtherance of business. Understanding the scope of 'immovable property' is very important. Immovable property is well understood to be land and building but it also includes everything that is attached to or forming part of the land and rights-in-land. Credit is blocked on all inward supplies leading to the establishment of such immovable property. Inward supply of services from real estate agent, architect, interior decorators and contractors are all blocked as these are involved in the establishment of the immovable property. But, if inward supplies such as security, house-keeping and property maintenance are used after construction, then such credits are not blocked as these are received after establishment of the immovable property. One needs to note the fine line that the law draws to prevent indiscriminate extension of this credit blockage beyond the purpose for which it is specified.

Factors to be considered for deciding whether the credits on costs associated with works contract or construction of immovable property are available or not

- (i) If rent charged separately for bare shell and the fitouts – No Credit in respect of inputs used in construction of bare shell whereas credits could be available on fitouts related material;
- (ii) Accounting treatment in the books – Are the costs capitalized with the Building or separately disclosed in the fixed asset register? Separate capitalization – Credit would be available;
- (iii) Things which cannot be retrieved without damage to the goods – Immovable and hence no credit;
- (iv) HSN Code in the Bill – If classified under the category of construction – Then credit is may not be available. There is a settled principle of law that incorrect classification by the supplier should not lead to denial if in normal circumstances it would be eligible;
- (v) Separate PO and Invoice from the vendor to bifurcate between transactions on which one would avail credits and on transactions on which one would not avail credits;
- (vi) Accounting of transactions and assigning the Project / Cost Code.

Please note that every structure is not immovable property. Please examine if the structure is a 'means of production' or the 'location of production'. Steel structures for gantry crane to move about would not be building but part of the supports for the crane. This area requires some technical insight and cannot be dismissed based on visual inspection by an untrained eye.

(e) Not used in business

Since credit reversal is required whenever inputs are lost, stolen or destroyed, distinction is to be made between inputs 'lost' and 'loss' of inputs. As stated earlier, credit is not liable to be reversed in case of 'loss' of inputs that do not amount to inputs being 'lost'. The loss could be either normal or abnormal (as per industry standards). Reversal of credit is occasioned when there is any event that results in inputs being 'lost'.

Stocks given away as gifts or free samples appear to be covered by this clause (h), but it is important to note that the manner of giving away gifts or free samples is qualified with the word 'disposal'. Disposal has already been used once before in section 7(1)(a) which is not the same as 'sale' or 'transfer'. Therefore, it appears that gift or free samples given must be such that they are not by way of 'sale' or 'transfer' (or any other form of supply). From our earlier discussion, undervaluation of stocks given away for non-monetary consideration was concluded to be a taxable supply. Here 'disposal' by way of gift or free samples must necessarily be stocks 'not meant for supply' that are to be distributed for non-monetary consideration. Some examples of goods 'not meant for supply' are as follows:

- Prescription drug samples marked 'Physician's sample not to be sold'
- As per the Legal Metrology (Packaged Commodity) Rules, 2011 sale of packaged commodities by a manufacturer, importer or wholesale dealer to an Industrial consumer shall have the declaration 'Not for retail sale'.

It is also important to understand that a supply that is rightly taxable cannot be substituted based on its being given away as gift or free samples by mere reversal of relatable input tax credit. Meaning to say, prescription drugs supplied across the counter free of cost cannot be classified as 'free sample' merely because it is supplied for free. The supplier of such goods cannot exempt himself from payment of tax on such goods by claiming to have reversed input tax credit proportionate to goods supplied for free. It is only when stocks that are 'not meant for sale' for supply are 'disposed off', the words 'in respect of' manages to recover input tax credit relatable to the inputs used in the production of such stocks that no longer make a taxable supply.

Some experts argue that nothing done in business is free and therefore reversal of ITC would be sufficient as it is in course and furtherance of business. This matter may also be tested in time to come.

CGST Amendment Act, 2018

Multiple amendments have been made to Section 17(5) of the CGST Act. The implications of the same have been provided below

1. Credits relating to motor vehicles (MV)

Category of Service	MV with seating capacity of 14 or more	MV with seating capacity or 13 or less*	
		For Re-sale, Transport by Transport Operator, Driving School	Other Use
Credit on MV	Available	Available	Not Available
Credit on repair,	Available	Available	Not

insurance, servicing etc			Available
Credit on Renting, Leasing or Hiring	Available	Available	Not Available

* Similar conditions prescribed for Aircraft and Vessel. Additionally, Aircraft and Vessel used for transport of goods will also be eligible purchases for credit availment

2. The Current law disallows credit on Motor Vehicle and other conveyances which can include two wheelers. However, the amended provisions refers to disallowance of credit only in case of Motor Vehicles. Section 2(17) of the Motor Vehicles Act, 1939 defines the term Motor Cycle to mean “two-wheeled motor vehicle” and Section 2(18) of the said Act defines Motor Vehicle to exclude “vehicle having less than four wheels”. Based on the above, we can observe that Motor Vehicles do not include Motor Cycles / Two wheelers and hence credit of the will be available under the Amendment Act.
3. Other employee benefit related entries have been merged and continue restriction of credit on the same unless they are used for providing output services or have been provided based on an obligation arising out of any law. For all the entries in clause (b) of Section 17(5), the input tax credit will be available in respect of goods or services where it is obligatory for an employer to provide the same to its employees under any law.

(f) Reversal of Input tax credit - Computation of Exempt Turnover and Total Turnover in the State

Rule 42 requires common credits used for taxable and exempt supplies to be availed in the same proportion as that of the taxable supplies to the Total Turnover in the State.

Total Turnover in the State means

- (i) Value of all taxable supplies (other than inward supplies covered under reverse charge) made within the State
- (ii) Value of all exempt supplies made within the State
- (iii) Exports
- (iv) Inter State Supplies

but excludes CGST, SGST, IGST and Compensation Cess.

Exempt Turnover means

Supply of any goods or services or both

- (i) which attracts nil rate of tax or

- (ii) which may be wholly exempt from tax under section 11, or under section 6 of the Integrated Goods and Services Tax Act, 2017

and includes

- (i) non-taxable supply – Supplies not leviable to tax under GST. Eg: Alcohol
- (ii) supplies on which the recipient is liable to pay tax on reverse charge basis – it would be treated as exempt in the hands of the supplier and not recipient. Eg: Sponsorship Services by Educational Institution would be treated as exempt supplies in the hands of educational institution since it attracts GST under reverse charge;
- (iii) Transaction in securities – Value shall be 1% of the sale value;
- (iv) Sale of Land – Value shall be the same as adopted for stamp duty purposes;
- (v) Sale of Completed Building on which GST is not applicable (sale after receipt of occupancy certificate or after first occupation) – Value shall be the same as adopted for stamp duty purposes.

but excludes

- (i) Excise Duty levied under Entry 84 of List 1 of the Seventh Schedule to the Constitution of India [applicable on petroleum crude, high speed diesel, motor spirit (commonly known as petrol), natural gas aviation turbine fuel and tobacco and tobacco products];
- (ii) Excise Duty levied under Entry 51 of List 2 of the Seventh Schedule to the Constitution of India [applicable on alcoholic liquor for human consumption and opium, Indian Hemp and other Narcotic drugs and narcotics];
- (iii) VAT on sale of goods under Entry 54 of List 2 of the Seventh Schedule to the Constitution of India [applicable on petroleum crude, high speed diesel, motor spirit (commonly known as petrol), natural gas aviation turbine fuel and tobacco and tobacco products];
[Explanation to Rule 43 – Amendment effective from January 25, 2018]
- (iv) Supply of Services to Nepal and Bhutan against Indian Rupee covered under Notification No.42/2017 – IGST (Rate) dated 27.10.2017 [Explanation to Rule 43]
- (v) Interest / Discount received on deposits, loans etc (except for Banks and other Financial Institutions) [Explanation to Rule 43]
- (vi) Services by Transport of Goods by vessel from customs station to place outside India [Explanation to Rule 43]

Exemption from GST was provided on services of transport of goods by vessel / aircraft from customs station to place outside India but only transport of vessel is excluded from definition of exempt supplies and hence input tax credit would have to reversed on transport of goods by aircraft.

The value of activities or transactions specified in Schedule III other than sale of land and subject to clause (b) of Paragraph 5 of Schedule III, sale of building. This provision is yet to be notified. Thereby, the following supplies will not be categorized as exempt supplies for the purpose of reversal even though they may be considered as activities or transactions which are considered as neither supply of goods nor supply of services:

1. Services by an employee to the employer in the course of or in relation to his employment.
2. Services by any court or Tribunal established under any law for the time being in force.
3.
 - (a) the functions performed by the Members of Parliament, Members of State Legislature, Members of Panchayats, Members of Municipalities and Members of other local authorities;
 - (b) the duties performed by any person who holds any post in pursuance of the provisions of the Constitution in that capacity; or
 - (c) the duties performed by any person as a Chairperson or a Member or a Director in a body established by the Central Government or a State Government or local authority and who is not deemed as an employee before the commencement of this clause.
4. Services of funeral, burial, crematorium or mortuary including transportation of the deceased.
5. Actionable claims, other than lottery, betting and gambling.
6. Supply of goods from a place in the non-taxable territory to another place in the non-taxable territory without such goods entering into India.
7.
 - (a) Supply of warehoused goods to any person before clearance for home consumption;
 - (b) Supply of goods by the consignee to any other person, by endorsement of documents of title to the goods, after the goods have been dispatched from the port of origin located outside India but before clearance for home consumption.”

It is pertinent to highlight high sea sales and merchant trading sales as mentioned in point (6) and (7) above in the above list of activities or transactions. Both these transactions were opined to be non taxable supply before the amendment. Since, non-taxable supplies are covered within the definition of exempt supplies the aforesaid transactions would also have been classified within exempt supplies. As a result they would have entailed reversal of input tax credit before the amendment. However, after the amendment has been notified, they are mandatorily out of the purview of exempt supply for the purpose of reversal. Thereby any input tax credit attributable to these transactions will not be considered for the purpose of reversal.

On completion of the financial year, input tax credit shall be determined accurately based on actuals, in the same manner as provided in Rule 42. A 'true up' is required to be done on an annual basis (between the amounts reversed for each tax period during the year and the

amount determined at the end of the financial year) and any excess credit availed needs to be reversed with interest while short credit, if any, needs to be re-availed within 6 months from end of the financial year.

(g) Goods or services or both on which tax has been paid under Section 10

Section 10 depicts the conditions to be fulfilled for a person falling under composition scheme. One of the conditions state that a person opting for the composition scheme should not collect any taxes from the recipient. As no taxes are paid by the recipient, no input tax credit can be availed by them either. This clause within Section 17(5) casts the restriction upon the recipient to not avail any input tax credit for taxes paid under composition scheme.

(h) Goods or services or both received by a non resident taxable person except on goods imported by him

A non resident taxable person is a person who temporarily supplies any goods or services within India even though they are not a resident of the taxable territory. For these persons, a restriction has been cast in respect of the goods or services received within India. In respect of the goods or services received within India, no input tax credit can be availed by them. However, they are free to avail the input tax credit of the goods imported by them from outside India.

(i) Goods lost, stolen, destroyed, written off or disposed of by way of gift or free samples

When any goods are bought, input tax credit on it may be eligible. However, if the goods are treated in any one of the ways given above, then the input tax credit availed may have to be reversed. Ofcourse, if the goods are purchased with the intent of using it for any of the aforesaid purposes, then input tax credit may not be availed in the first place.

It may be noted here that all the above ways stated in respect of goods are exhaustive. Any goods which are treated in any other manner will not be restricted from input tax credit. Any inward supplies in respect of goods which are used for business promotion or exhibition may not attract any of the restrictive words given above. Thereby, input tax credit in respect of those may be considered as available. A short description of each of the words given above are depicted below:

- a. Lost – This can include goods getting lost as part of process loss due to any abnormal dysfunction. Ideally normal losses should not entail any reversal of input tax credit.
- b. Stolen – When any goods are found to be lower upon physical verification, it may be considered as stolen. This will require reversal of any input tax credit taken earlier
- c. Destroyed – Any goods which get destructed due to any natural calamity like flood, earthquake or a man made event like fire, water leakage etc. However, if the goods reach to a certain level of destruction that it cannot be possibly reversed, then this clause gets attracted.
- d. Written off – If any goods are having a certain value as per the books of accounts but

are completely written off due to any reason, this clause will get attracted. This can include goods getting written off due to obsolescence or lapse of time.

- e. Disposed off by way of gift or free samples – Any goods which are disposed through these two mechanisms will be covered here. Ideally gift is given out of natural love and affection and does not involve any business motive (at least not clearly evident). For instance, a shirt manufacturer giving his relative his brand of shirt during any occasion will be covered here.

The second instance of disposal covered here can be free samples. Any goods which are disposed as a free sample to enthruse the buyer to buy more in future can be covered here. The input tax credit on such goods are considered to be blocked by Section 17(5)(h). It may be noted that the free sample should only be in respect of the goods getting marketed. If lets us say a calendar, diary etc. is given a manufacturer to their dealers as part of brand promotion, the same will not be covered here. Ideally, input tax credit on this should be allowed on these goods assuming the manufacturer is not dealing in them.

Implications under GST in case of Expired Medicines

In case of Pharmaceutical Industry, the medicines carry expired date and it is the duty of the manufacturer to destroy the unsold medicines on the date of expiry. Accordingly, the manufacturer collects such unsold expired medicines from various levels in the supply chain and destroys the expired medicine based on the provisions of the Drugs and Cosmetics Act, 1940. It would be relevant to note that the manufacturer compensates the supply chain for loss due to expired medicine. Circular 72/2018 has been issued to highlight the implications under GST on such expired medicine. These implications have been discussed below by way of an example

Assumption

- Medicine purchased / imported at Rs 100 and GST paid Rs 5
- Medicine sold to Distributor at Rs 200 and GST charged Rs 10

Scenario	Clarification Issued – Options	Implications
Original Sale 2017-18 (till March 31, 2018) Expired Stock Returned By September 30, 2018	<u>Option 1</u> 1. Seller to issue credit note to Distributor for Rs 100 + 10 2. Distributor to reverse credit of Rs 10 3. Seller to reverse credit of Rs 5 (GST paid on procurement)	Seller to receive expired stock under credit note route (option 1) and thereby restrict credit reversal to the tax paid on procurement
	<u>Option 2</u> 1. Distributor to issue Invoice	

	<p>for Rs 100 + 10</p> <ol style="list-style-type: none"> 2. Seller to avail credit of the same 3. On destruction of goods, Seller to reverse credit of Rs 10 (GST paid on sales) 	
<p>Original Sale 2017-18 (till March 31, 2018)</p> <p>Expired Stock Returned after September 30, 2018</p>	<p>Option 1</p> <ol style="list-style-type: none"> 1. Seller to issue credit note to Distributor for Rs 100 + Rs 0 2. No implications on distributor and credit availed by them on original supply may not be questioned as per the clarification of the Circular which provides that credit notes can be issued even after 6 months from the end of the FY but from the perspective of the distributor, he has availed credit on stocks against which he does not have a corresponding output and hence issues on credit eligibility in the hands of distributor may arise. Hence, distributor can ask for compensation of Rs 10 credit lost by him 3. Seller to reverse credit of Rs 5 (GST paid on procurement) <p>Option 2</p> <ol style="list-style-type: none"> 1. Distributor to issue Invoice for Rs 100 + 10 2. Seller to avail credit of the same 3. On destruction of goods, Seller to reverse credit of Rs 10 (GST paid on sales) 	<p>Option 1 leads to reversal of credit of Rs 15 whereas Option 2 leads to reversal of credit of Rs 10.</p> <p>Effectively, the manufacturer is required to reverse credit on the selling price which can be substantial amount.</p> <p>This needs to be examined specifically in terms of Section 18 of Drugs and Cosmetics Act, 1940 which prohibits sale of Expired Stock</p>

* It is a wonder how 'expired medicines' can at all enjoy same HSN and 'medicines'. Surely, something has occurred that brings about this categorization as 'expired'. And when HSN cannot remain the same, inquiry is required into what is the 'object of supply'. Is it some other goods or when it is not any kind of goods, is it therefore a service (in GST terms)?

(j) Any taxes paid in accordance with the provisions of Sections 74, 129 and 130

Section 74 talks about payment of taxes in a situation where taxes is not paid or short paid or erroneously refunded or input tax credit wrongly availed or utilized by reason of fraud or willful misstatement or suppression of facts. If the supplier is making payment of taxes under forward charge due to the aforesaid reasons, no input tax credit will be available to the recipient. In case of reverse charge, if the recipient is making payment of taxes under this section, even the recipient will not be allowed to avail input tax credit.

Section 129 talks about detention, seizure and release of goods and conveyance in transit. Further, Section 130 mentions about confiscation of goods and/or conveyance and levy of penalty. In both the cases if any payment is made by any person under these sections, no input tax credit in respect of these will be available.

Through this point, input tax credit is proposed to be blocked wherever mens rea is proven/accepted. In such cases, since taxes had not been paid earlier due to any fraudulent intent, no input tax credit is allowed by the law.

17.3 Issues and Concerns

- (i) Sub-Sections (c) and (d) of Section 17(5) restricts input tax credit when received towards construction of immovable property. The term 'construction' used in Section 17 has been explained to includes re-construction, renovation, additions or alterations or repairs to an immovable property only to the extent it has been capitalised in the books of accounts. Would this mean that any renovation, additions or alterations or repairs to an immovable property which is not capitalised would still be an eligible input tax credit as long as it fulfils the conditions in Section 16 of the Act. For example, a service provider replaces broken windows in his office, the cost of which has not been capitalised in its books of accounts, instead the entire amount has been charged to the profit and loss account along with taxes. Would the company still be eligible to avail input tax credit since there is no restriction on availing the said tax credits either under Section 17(5) or under Section 16(3).
- (ii) Now the question arises as to whether input tax credit incurred on special purpose motor vehicles such as cranes, drilling and excavation vehicles such as bore well drilling lorries and bulldozers which cannot be claimed to be used in transportation of goods. Section 17(5) restricts input tax credit on Motor vehicles and other conveyances unless the same has been used in the transportation of goods or for effecting taxable supplies such as further supply of the motor vehicle, transportation of passengers or imparting training for driving such vehicles. The GST Act borrows the definition of a motor vehicle from section 2(28) of the Motor Vehicles Act, 1988 which is defined as "*any mechanically propelled vehicle adapted for use upon roads whether the power of propulsion is transmitted thereto from an external or internal source and includes a*

chassis to which a body has not been attached and a trailer; but does not include a vehicle running upon fixed rails or a vehicle of a special type adapted for use only in a factory or in any other enclosed premises or a vehicle having less than four wheels fitted with engine capacity of not exceeding thirty-five cubic centimeters;” In view of the above definition, a crane, borewell or a bulldozer can be said to be a motor vehicle. In the past cenvat regime where similar restriction existed, the credit was allowed. This aspect may be tested in time to come.

- (iii) The credit which is not specifically attributable to exempt or taxable supplies would be treated as common credit and would be subject to reversal of credits in the proportion of exempt supplies over total supplies. There could be circumstances where the credit is not related to an exempt or taxable supply and yet not common for the entire business but only a particular cost centre / project. Eg. XYZ Builders are engaged in construction of residential complexes and sale thereof. Currently, two projects at two different locations in the State of Uttar Pradesh are under execution. Project 1 – OC received and certain improvement cost incurred on which GST has been charged by the vendor. Project 2 – Under Construction. Credits of Projects 1 are not exclusively used for exempt nor exclusively used for taxable purposes. To the extent the credit relates to apartments sold before OC, these are for taxable purposes and to the extent the credit relates to apartments sold after OC, these are for exempt purposes. Since these are not exclusive to taxable or exempt supplies, these would be treated as common credits and their availment would depend on the turnover of the entire company and not merely Project 1. It would be important to note that Rule 6 of the CENVAT Credit Rules, 2004 allowed for maintenance of separate records for availment of credit and a tax payer would use this rule to reverse the credit related to Project 1 based on the turnover / area sold after OC of project 1.

17.4 Comparative Review

Aspect	Credit under old regime	Input tax credit under GST regime
Proportionate credit	No explicit distinction made between goods or services used for business and non-business	Specific distinction made between goods or services used for business and non-business
Works contract credit	Restriction to inputs only	Credit allowed when used for further supply of works contract
Credit on inputs used for construction of immovable property	Input or Input Service used for civil construction not eligible.	Restriction to both inputs and input services.
Credit related to works contract and	Plant and machinery not excluded from restriction of	Plant and machinery is excluded from restriction of

construction w.r.t plant and machinery	credit	credit unless depreciation has been claimed on the tax component.
--	--------	---

17.5 FAQs

Q1. Where goods or services or both received, is used for both taxable and non-taxable supplies, what would be the input tax credit entitlement for the registered person?

Ans. The input tax credit of goods or service or both used in respect of taxable supplies can only be availed by the registered person

Q2. Whether the taxable supply would include supplies on which tax is payable by recipient on reverse charge basis?

Ans. No.

17.6 MCQs

Q1. Which of the following is included for computation of taxable supplies for the purpose of availing credit?

- (a) Zero-rated supplies
- (b) Exempt supplies
- (c) Both
- (d) None of the above

Ans. (a) Zero Rated supplies

Statutory Provisions**18. Availability of credit in special circumstances**

- (1) *Subject to such conditions and restrictions as may be prescribed-*
- (a) *A person who has applied for registration under the Act within thirty days from the date on which he becomes liable to registration and has been granted such registration shall, be entitled to take credit of input tax in respect of inputs held in stock and inputs contained in semi-finished or finished goods held in stock on the day immediately preceding the date from which he becomes liable to pay tax under the provisions of this Act.*
 - (b) *A person, who takes registration under sub-section (3) of section 25 shall, be entitled to take credit of input tax in respect of inputs held in stock and inputs contained in semi-finished or finished goods held in stock on the day immediately preceding the date of grant of registration.*
 - (c) *Where any registered person ceases to pay tax under section 10, he shall be entitled to take credit of input tax in respect of inputs held in stock, inputs contained in semi-finished or finished goods held in stock and on capital goods on the day immediately*

preceding the date from which he becomes liable to pay tax under section 9

Provided that the credit on capital goods shall be reduced by such percentage points as may be prescribed

- (d) *Where an exempt supply of goods or services or both by a registered person becomes a taxable supply, such person shall be entitled to take credit of input tax in respect of inputs held in stock and inputs contained in semi-finished or finished goods held in stock relating to such exempt supply and on capital goods exclusively used for such exempt supply on the day immediately preceding the date from which such supply becomes taxable:*

Provided that the credit on capital goods shall be reduced by such percentage points as may be prescribed

- (2) *A registered person shall not be entitled to take input tax credit under sub-section (1), in respect of any supply of goods or services or both to him after the expiry of one year from the date of issue of tax invoice relating to such supply.*
- (3) *Where there is a change in the constitution of a registered person on account of sale, merger, demerger, amalgamation, lease or transfer of the business with the specific provision for transfer of liabilities, the said registered person shall be allowed to transfer the input tax credit which remains unutilized in his electronic credit ledger to such sold, merged, demerged, amalgamated, leased or transferred business in such manner as may be prescribed.*
- (4) *Where any registered person who has availed of input tax credit opts to pay tax under section 10 or, where the goods or services or both supplied by him become wholly exempt, he shall pay an amount, by way of debit in the electronic credit ledger or electronic cash ledger, equivalent to the credit of input tax in respect of inputs held in stock and inputs contained in semi-finished or finished goods held in stock and on capital goods, reduced by such percentage points as may be prescribed, on the day immediately preceding the date of exercising such option or, as the case may be, the date of such exemption:*
- Provided that after payment of such amount, the balance of input tax credit, if any, lying in his electronic credit ledger shall lapse.*
- (5) *The amount of credit under sub-section (1) and the amount payable under sub-section (4) shall be calculated in such manner as may be prescribed*
- (6) *In case of supply of capital goods or plant and machinery, on which input tax credit has been taken, the registered person shall pay an amount equal to the input tax credit taken on the said capital goods or plant and machinery reduced by such percentage points as may be prescribed or the tax on the transaction value of such capital goods or plant and machinery determined under section 15, whichever is higher:*

Provided that where refractory bricks, moulds and dies, jigs and fixtures are supplied as scrap, the taxable person may pay tax on the transaction value of such goods determined under section 15.

Extract of the CGST Rules, 2017

40. Manner of claiming credit in special circumstances.

(1) *The input tax credit claimed in accordance with the provisions of sub-section (1) of section 18 on the inputs held in stock or inputs contained in semi-finished or finished goods held in stock, or the credit claimed on capital goods in accordance with the provisions of clauses (c) and (d) of the said sub-section, shall be subject to the following conditions, namely, -*

a) *the input tax credit on capital goods, in terms of clauses (c) and (d) of sub-section (1) of section 18, shall be claimed after reducing the tax paid on such capital goods by five percentage points per quarter of a year or part thereof from the date of the invoice or such other documents on which the capital goods were received by the taxable person.*

b) *the registered person shall within a period of thirty days from the date of becoming eligible to avail the input tax credit under sub-section (1) of section 18, or within such further period as may be extended by the Commissioner by a notification in this behalf, shall make a declaration, electronically, on the common portal in FORM **GST ITC-01** to the effect that he is eligible to avail the input tax credit as aforesaid:*

Provided that any extension of the time limit notified by the Commissioner of State tax or the Commissioner of Union territory tax shall be deemed to be notified by the Commissioner.

c) *the declaration under clause (b) shall clearly specify the details relating to the inputs held in stock or inputs contained in semi-finished or finished goods held in stock, or as the case may be, capital goods—*

i. *on the day immediately preceding the date from which he becomes liable to pay tax under the provisions of the Act, in the case of a claim under clause (a) of sub-section (1) of section 18;*

ii. *on the day immediately preceding the date of the grant of registration, in the case of a claim under clause (b) of sub-section (1) of section 18;*

iii. *on the day immediately preceding the date from which he becomes liable to pay tax under section 9, in the case of a claim under clause (c) of sub-section (1) of section 18;*

iv. *on the day immediately preceding the date from which the supplies made by the registered person becomes taxable, in the case of a claim under clause (d) of sub-section (1) of section 18;*

- d) *the details furnished in the declaration under clause (b) shall be duly certified by a practicing chartered accountant or a cost accountant if the aggregate value of the claim because central tax, State tax, Union territory tax and integrated tax exceeds two lakh rupees;*
- e) *the input tax credit claimed in accordance with the provisions of clauses (c) and (d) of sub-section (1) of section 18 shall be verified with the corresponding details furnished by the corresponding supplier in FORM GSTR-1 or in FORM GSTR- 4 , on the common portal.*
- (2) *The amount of credit in the case of supply of capital goods or plant and machinery, for the purposes of sub-section (6) of section 18, shall be calculated by reducing the input tax on the said goods at the rate of five percentage points for every quarter or part thereof from the date of the issue of the invoice for such goods.*

41. Transfer of credit on sale, merger, amalgamation, lease or transfer of a business

- (1) *A registered person shall, in the event of sale, merger, de-merger, amalgamation, lease or transfer or change in the ownership of business for any reason, furnish the details of sale, merger, de-merger, amalgamation, lease or transfer of business, in FORM GST ITC-02, electronically on the common portal along with a request for transfer of unutilized input tax credit lying in his electronic credit ledger to the transferee:*
- Provided that in the case of demerger, the input tax credit shall be apportioned in the ratio of the value of assets of the new units as specified in the demerger scheme.*
- (2) *The transferor shall also submit a copy of a certificate issued by a practicing chartered accountant or cost accountant certifying that the sale, merger, de-merger, amalgamation, lease or transfer of business has been done with a specific provision for the transfer of liabilities.*
- (3) *The transferee shall, on the common portal, accept the details so furnished by the transferor and, upon such acceptance, the un-utilized credit specified in FORM GST ITC02 shall be credited to his electronic credit ledger.*
- (4) *The inputs and capital goods so transferred shall be duly accounted for by the transferee in his books of account.*

41A. Transfer of credit on obtaining separate registration for multiple places of business within a State or Union territory

- 1) *A registered person who has obtained separate registration for multiple places of business in accordance with the provisions of rule 11 and who intends to transfer, either wholly or partly, the unutilised input tax credit lying in his electronic credit ledger to any or all of the newly registered place of business, shall furnish within a period of thirty days from obtaining such separate registrations, the details in FORM GST ITC-02A electronically on the common portal, either directly or through a Facilitation Centre notified in this behalf by the Commissioner:*

Provided that the input tax credit shall be transferred to the newly registered entities in the ratio of the value of assets held by them at the time of registration.

Explanation.- For the purposes of this sub-rule, it is hereby clarified that the 'value of assets' means the value of the entire assets of the business whether or not input tax credit has been availed thereon.

- 2) The newly registered person (transferee) shall, on the common portal, accept the details so furnished by the registered person (transferor) and, upon such acceptance, the unutilised input tax credit specified in FORM GST ITC-02A shall be credited to his electronic credit ledger.

44. Manner of reversal of credit under special circumstances

- 1) *The amount of input tax credit relating to inputs held in stock, inputs contained in semi-finished and finished goods held in stock, and capital goods held in stock shall, for the purposes of sub-section (4) of section 18 or sub-section (5) of section 29, be determined in the following manner, namely,-*

- a) *for inputs held in stock and inputs contained in semi-finished and finished goods held in stock, the input tax credit shall be calculated proportionately on the basis of the corresponding invoices on which credit had been availed by the registered taxable person on such inputs;*
- b) *for capital goods held in stock, the input tax credit involved in the remaining useful life in months shall be computed on pro-rata basis, taking the useful life as five years.*

Illustration:

Capital goods have been in use for 4 years, 6 month and 15 days.

The useful remaining life in months= 5 months ignoring a part of the month

Input tax credit taken on such capital goods= C

Input tax credit attributable to remaining useful life= C multiplied by 5/60

- 2) *The amount, as specified in sub-rule (1) shall be determined separately for input tax credit of central tax, State tax, Union territory tax and integrated tax.*
- 3) *Where the tax invoices related to the inputs held in stock are not available, the registered person shall estimate the amount under sub-rule (1) based on the prevailing market price of the goods on the effective date of the occurrence of any of the events specified in subsection (4) of section 18 or, as the case may be, sub-section (5) of section 29.*
- 4) *The amount determined under sub-rule (1) shall form part of the output tax liability of the registered person and the details of the amount shall be furnished in FORM GST ITC03, where such amount relates to any event specified in sub-section (4) of section 18 and in FORM GSTR-10, where such amount relates to the cancellation of registration.*

- 5) *The details furnished in accordance with sub-rule (3) shall be duly certified by a practicing chartered accountant or cost accountant.*
- 6) *The amount of input tax credit for the purposes of sub-section (6) of section 18 relating to capital goods shall be determined in the same manner as specified in clause (b) of sub-rule (1) and the amount shall be determined separately for input tax credit of central tax, State tax, Union territory tax and integrated tax:*
- Provided that where the amount so determined is more than the tax determined on the transaction value of the capital goods, the amount determined shall form part of the output tax liability and the same shall be furnished in FORM GSTR-1.*

44A. Manner of reversal of credit of Additional duty of Customs in respect of Gold dore bar. -

The credit of Central tax in the electronic credit ledger taken in terms of the provisions of section 140 relating to the CENVAT Credit carried forward which had accrued on account of payment of the additional duty of customs levied under sub-section (1) of section 3 of the Customs Tariff Act, 1975 (51 of 1975), paid at the time of importation of gold dore bar, on the stock of gold dore bar held on the 1st day of July, 2017 or contained in gold or gold jewellery held in stock on the 1st day of July, 2017 made out of such imported gold dore bar, shall be restricted to one-sixth of such credit and five-sixth of such credit shall be debited from the electronic credit ledger at the time of supply of such gold dore bar or the gold or the gold jewellery made therefrom and where such supply has already been made, such debit shall be within one week from the date of commencement of these Rules.

Relevant circulars, notifications, clarifications issued by Government:

- Chapter Nineteen of the compilation of the GST Flyers as issued by the CBIC on 'Input Tax Credit Mechanism in GST'

Related Provisions of the Statute

Section or Rule	Description
Section 2(19)	Definition of 'Capital Goods'
Section 2(59)	Definition of 'Inputs'
Section 2(60)	Definition of 'Input Services'
Section 25	Procedure for registration
Section 9	Levy and collection
Section 10	Composition levy
Rule 44	Manner of reversal of credit under special circumstances

18.1 Introduction

Input tax credit is normally available to a registered person who engages in taxable outward supplies and such person not being a composition person. However, in certain cases, credit would be available on inputs held in stock, inputs contained in semi-finished and finished goods and on capital goods even though the supplier was unregistered or engaged in exempt supplies or was under the composition scheme on the date of procurement of such goods or services. Conversely, instances where input tax credit legitimately availed needs to be reversed has also been dealt with under this Section.

18.2 Analysis

Eligibility of input tax credit on inputs held in stock and contained in semi-finished and finished goods held in stock: The credit on inputs held in stock and inputs contained in semi-finished goods and finished goods held in stock is available in the following manner:

Supplier	Inputs	Input Services	Capital Goods	Stock to be considered as on
Liabe for registration (crosses the turnover of Rs 20 Lakhs) – Applies for registration within 30 days of becoming liable for registration and obtains registration	Available	Not Available	Not Available	Day immediately preceding the date from which he becomes liable to pay tax
Voluntary Registration	Available	Not Available	Not Available	Day immediately preceding the date of grant of registration
Composition Scheme to Regular Scheme	Available	Not Available	Available	Day immediately preceding the date from which supplier is liable to pay tax under regular scheme
Exempt Supplies become Taxable	Available	Not Available	Available (Only for capital goods used exclusively for exempt supplies)	Day immediately preceding the date from which exempt supplies become taxable

Note – The challenges on eligibility uniformly is before the Courts under Article 14, which may enable one to avail the credit in case the decisions are favourable..

Credit on inputs includes inputs and inputs contained in semi-finished and finished goods. Credit on input services is not available under any circumstance.

- Declaration in Form GST ITC-01 must be filed within thirty days from the date of becoming eligible to input tax credit. Rule 40 of Central Goods and Service Tax Rules, 2017 requires a declaration to be filed containing details of stocks and capital goods along with a certificate from a practicing Chartered Accountant or Cost Accountant where the aggregate credit of CGST, SGST/UTGST and IGST so claimed exceeds ₹ 2 lakhs.
- The supplier would not be entitled to credit of goods or services or both after expiry of 1 year from date of issue of tax invoice (this restriction applies even to capital goods though this may not have been the intention).
- The credit on capital goods shall be reduced by five percentage per quarter or part thereof from the date of invoice.
- Credits are subject to verification of details furnished by the supplier in GSTR-1 or GSTR-4 on the common portal only in case of conversion from composition to regular scheme or when exempt supplies become taxable supplies. Verification is not possible for new registration cases as the supplier was unregistered at the time of procurement.

Examples:

- (i) A person becomes liable to pay tax on 1st August 2017 and has obtained registration on 15th August 2017. Such person is eligible for input tax credit on inputs held in stock as on 31st July 2017.
- (ii) Mr. Ann applies for voluntary registration on 5th June 2017 and obtained registration on 22th June 2017. Mr. A is eligible for input tax credit on inputs in stock as on 21st June 2017.
- (iii) Mr. B, registered person was paying tax under composition rate upto 30th July 2017. However, w.e.f 31st July 2017. Mr. B becomes liable to pay tax under regular scheme. Mr. B is eligible for input tax credit on inputs held in stock as on closure of business hours on 30th July 2017.

Illustration (Rule 40): Manner of claiming credit in special circumstances

Akshay Steels Limited is a manufacturer of iron & steel. It procures raw materials and inputs such as iron ore, chemicals, gases, etc. and capital goods including plant & machinery, for the manufacture of such iron & steel. In this example, it has been assumed that iron & steel (which is the outward supply of Akshay Steels Ltd) is exempt from payment of taxes until 31-Mar-2020. Iron & steel become taxable with effect from 01-Apr-2020. The method of availment of input tax credits on inputs contained in stock and capital goods as on 31-Mar-2020 is covered by this illustration

Particulars	Amount (₹)
Value of inputs in stock on 31-Mar-2020	1,00,000
IGST @18%	18,000
All inputs were procured after 01-Jul-2019	
Value of inputs contained in semi-finished goods held in stock on 31-Mar-2020	4,00,000
CGST @ 6%	24,000
SGST @ 6%	24,000
All inputs contained in semi-finished goods were procured after 01-May-2019	
Value of inputs contained in finished goods held in stock on 31-Mar-2020	50,000
CGST @ 6%	3,000
SGST @ 6%	3,000
Only inputs worth ₹ 40,000 in finished goods were procured after 01-Apr-2019	
Capital Goods procured vide invoice dated 22.01.2020	20,00,000
IGST Paid @ 18%	3,60,000
Credit available in respect of inputs:	
CGST (Note 1)	26,400
SGST (Note 2)	26,400
IGST (Note 3)	18,000
Total credit available on inputs	70,800
Value of capital goods used exclusively in relation to exempted goods held on 31-Mar-2020	20,00,000
IGST @ 18%	3,60,000
Credit available in respect of capital goods:	
Date of invoice of capital goods	22-Jan-2020
Date from which the exempt goods become taxable	01-Apr-2020
No. of quarters from date of invoice	1

Percentage points to be reduced (5% per quarter) (Note 4)	5%
IGST paid on the capital goods used exclusively in relation to goods exempted up to 31-Mar-2020	3,60,000
ITC to be reduced by 5%	(18,000)
Credit (IGST) available on capital goods	3,42,000

Working notes:

Note 1: CGST credits on inputs in stock held on 31-Mar-2020:

a	ITC on the value of inputs		
b	ITC on the value of inputs contained in semi-finished goods: All inputs were acquired within 1 year prior to the effective date on which the goods become taxable. Hence, entire ITC would be allowed.	24,000	
c	ITC on the value of inputs contained in finished goods: Out of the total stock of ₹ 50,000/-, inputs totalling to ₹ 10,000/- are older than 1 year from the effective date on which the goods become taxable. Therefore, ITC to this extent stands disallowed. ITC on inputs contained in stock of ₹ 40,000 would be eligible. [Eligible credit = 40,000 * 6%]	2,400	
	CGST credit available on inputs		26,400

Note 2: SGST credits on inputs in stock held on 31-Mar-2020:

a	ITC on the value of inputs		
b	ITC on the value of inputs contained in semi-finished goods: <i>Refer Note 1</i>	24,000	
c	ITC on the value of inputs contained in finished goods: <i>Refer Note 1</i>	2,400	
	SGST credit available on inputs		26,400

Note 3: IGST credits on inputs on stock held on 31-Mar-2020:

a	ITC on the value of inputs: All inputs were acquired within 1 year prior to the effective date on which the goods become taxable. Hence, entire ITC would be allowed.	18,000	
b	Input tax credit on the value of inputs contained in semi-finished goods	-	
c	Input tax credit on the value of inputs contained in finished goods	-	
	IGST credit available on inputs		18,000

Note 4: Rule 40(1)(a) of the Central Goods and Service Tax Rules, 2017 provides that input tax credit on capital goods can be claimed after reducing 5% per quarter of a year or part thereof, from the date of invoice in respect of which capital goods are received. Therefore, the number of quarters is 1, being the first quarter of the year 2020. The reversal of credit would therefore be, to the extent of ₹ 18000 (5% of ₹ 3,60,000).

Illustration (Rule 42): Manner of determination of ITC in respect of inputs or input services and reversal thereof

Rule 42 of the Central Goods and Services Tax Rules, 2017

Sl. No	Particulars	Reference	CGST	SGST/UTGST	IGST
1	Total input tax on inputs and input services for the tax period May 2018	T	1,00,000	1,00,000	50,000
	Out of the total input tax (T):				
2	Input tax used exclusively for non-business purposes (Note 1)	T1	10,000	10,000	5,000
3	Input tax used exclusively for effecting exempt supplies (Note 1)	T2	10,000	10,000	5,000
4	Input tax ineligible under Section 17(5) (Note 1)	T3	5,000	5,000	2,500
	Total		25,000	25,000	12,500
	ITC credited to Electronic Credit Ledger (Note 1)	$C1 = T - (T1 + T2 + T3)$	75,000	75,000	37,500
	Input tax credit used exclusively for taxable supplies (including zero-rated supplies)	T4	50,000	50,000	25,000
	Common credit	$C2 = C1 - T4$	25,000	25,000	12,500
	Aggregate value of exempt supplies for the tax period May 2018 (Note 2 & 3)	E	25,00,000	25,00,000	25,00,000

Total Turnover of the registered person for the tax period May 2018 (Note 2)	F	1,00,00,000	1,00,00,000	1,00,00,000
Credit attributable to exempt supplies	$D1 = (E/F) * C2$	6,250	6,250	3,125
Credit attributable to non-business purposes	$D2 = C2 * 5\%$	1,250	1,250	625
Net eligible common credit	$C3 = C2 - (D1 + D2)$	17,500	17,500	8,750
Total credit eligible (Exclusive + Common)	G = T4 + C3	67,500	67,500	33,750

Note 1: T1, T2, T3 and T4 shall be determined as above and declared in Form GSTR-2 at the invoice level.

Note 2: If the registered person does not have any turnover for May 2018, then the value of Exempt Supplies (E) and Total Turnover (F) shall be considered for the last tax period for which such details are available

Note 3: Aggregate value excludes taxes

Note 4: The registered person is expected to make such computation for each tax period and reverse the same in the periodic returns being filed by such registered person. However, on completion of the financial year, input tax credit shall be determined accurately based on actuals, in the same manner as provided in Rule 42. A true up is required to be done on an annual basis (between the amounts reversed for each tax period during the year and the amount determined at the end of the financial year) and any excess credit availed needs to be reversed with interest while short credit, if any, needs to be re-availed within 6 months from end of the financial year.

It is to be noted that the registered person would be required to remit excess ITC claimed (as determined in Note 4 above) with interest calculated at for the period starting from the first day of April of the succeeding financial year till the date of payment. However, no interest can be claimed if, at the end of the financial year, it is found that short credit was availed.

Illustration (Rule 43): Manner of determination of ITC in respect of capital goods and reversal thereof in certain cases

Sl. No	Particulars	Reference	IGST
1	ITC on capital goods used exclusively for non-business purposes (Note 1)	T1	10,000

2	ITC on capital goods used exclusively for effecting exempt supplies (Note 1)	T2	10,000
	Total		20,000
3	ITC on capital goods used exclusively for taxable supplies (including zero-rated supplies) (Note 1)	T3	50,000
4	ITC on capital goods (other than T1, T2 and T3) (Annexure A)	A= b+f	3,90,000
5	ITC on capital goods whose residual life remain in beginning of tax period (Annexure A)	Tr	6,500
7	Aggregate value of exempt supplies for the tax period May 2018 (Note 2 & 3)	E	25,00,000
8	Total Turnover of the registered person for the tax period May 2018 (Note 2)	F	1,00,00,000
10	Credit attributable to exempt supplies	$T_e = \frac{(E/F) *}{Tr}$	1,625

Note 1: T1, T2 and T3 should be declared in Form GSTR-2. T3 (being ITC on capital goods used for taxable supplies) and A (being common credit in respect of capital goods) shall only be credited to the electronic credit ledger

Note 2: If the registered person does not have any turnover for May 2018, then the value of E and F shall be considered for the last tax period for which such details are available

Note 3: Aggregate value excludes taxes

Annexure A - ITC on capital goods whose residual life is remaining

Sl. No	Particulars	Reference	Amount
For May 2018			
1	Inward supply value of Machinery X	A	12,50,000
	IGST @ 12%	B	1,50,000
	Invoice Value		14,00,000
	Date of inward supply		12 April 2018
	Life of the capital goods (in months) - for GST purpose is 5 years	C	60
	ITC attributable for 1 month	$T_{m1} = b/c$	2500
2	Inward supply value of Machinery Y	E	20,00,000
	IGST @ 12%	F	2,40,000

	Invoice Value		22,40,000
	Date of inward supply		21 May 2018
	Life of the capital goods (in months) - for GST purpose is 5 years	G	60
	ITC attributable for May 2018 (1 month)	$Tm2 = f/g$	4000
	Aggregate of ITC on common credits	$Tr = Tm1 + Tm2$	6500

Rule 44 mandates credit reversal when a registered person switches from regular scheme to composition scheme or goods and services supplied by him become wholly exempt:

- Pay an amount by debiting electronic cash ledger / credit ledger, equivalent to input tax credit of -
 - Inputs held in stock
 - Inputs contained in semi-finished or finished goods held in stock and
 - Capital goods
- On the day immediately preceding the date of such switch over.
- Balance of input tax credit lying in the electronic credit ledger, after payment of the above said amount, shall lapse.
- Such amount is calculated in manner to be prescribed

Pay and Exit Scheme:

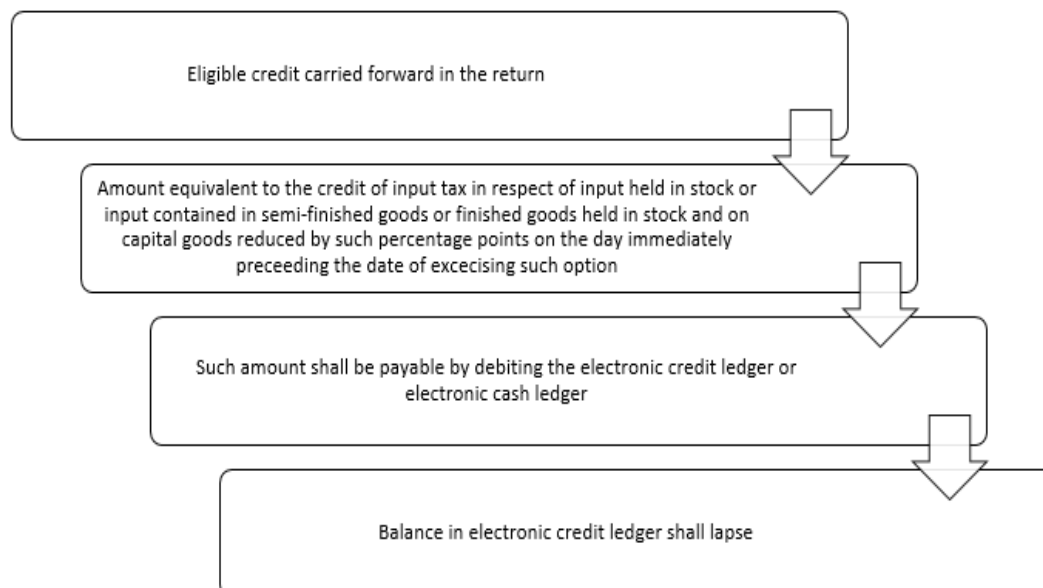

Illustration 1: Where input tax credit lapses

Sl. No	Particulars	Reference	Amount
1	Value of capital goods		1,00,000
	IGST @ 12%	A	12,000
	Invoice Value		1,12,000
2	Date of shift to composition scheme		01 April 2019 (Can be opted in Financial year beginning)
3	Date of inward supply and use of capital goods		01 September 2017
4	Period of use (days)		577
	Period of use (months)		19
5	Residual life in months	B	41
	(Considering full life as 5 years)		
6	ITC attributable to residual life (To be added to the output tax liability of the registered person)	$C = (A*B/60)$	8,200
5	Balance of ITC as on 31.03.2019		10,000
6	ITC utilized for capital goods for residual life		8,200
7	Balance ITC - would lapse		1,800

Illustration 2: Where input tax credit becomes payable

Sl. No	Particulars	Reference	Amount
1	Value of capital goods		1,00,000
	IGST @ 12%	A	12,000
	Invoice Value		1,12,000
2	Date of shift to composition scheme		1st April 2019
3	Date of inward supply and use of capital goods		01 September 2017
4	Period of use (days)		577
	Period of use (months)		19
5	Residual life in months	B	41
	(Considering full life as 5 years)		

6	ITC attributable to residual life	$C = (A*B/60)$	8,200
	(To be added to the output tax liability of the registered person)		
5	Balance of ITC as on 31.03.2019		1,500
6	ITC utilized for capital goods for residual life		8,200
7	Balance tax payable		6,700

Illustration 3: Where no payment is required

Sl. No	Particulars	Reference	Amount
1	Value of capital goods		1,00,000
	IGST @ 12%	A	12,000
	Invoice Value		1,12,000
2	Date of shift to composition scheme		1st April, 2023
3	Date of inward supply and use of capital goods		01 September 2017
4	Period of use (months)		67
	Period of use (years)		5 years 7 months
5	Residual life in months	B	-
	(Considering full life as 5 years)		
6	ITC attributable to residual life	$C = (A*B/60)$	0
	(No payment required)		

Input tax credit and change in constitution of registered person: The change in constitution of registered person due to sale, merger, demerger, amalgamation, lease or transfer or change in the ownership of business including transfer of liabilities provides for the following:

- (i) The registered person is allowed to transfer the input tax credit remaining unutilized in the electronic credit ledger .to such sold, merged, demerged, amalgamated, leased or transferred business.
- (ii) Rule 41 prescribes such credit transfer be made on the Common Portal in FORM GST ITC-02 and in case of demerger, credit to be transferred must be apportioned to the value of assets transferred in the arrangement to each such unit.

- (iii) A practicing Chartered Accountant or Cost Accountant to certify that the arrangement contains a specific provision for the transfer of liabilities.
- (iv) Details furnished in Form GST ITC-02 by the transferor would have to be accepted by the transferee on the Common Portal. Please refer to discussion on Registrations in case of such arrangements to examine the timing of seeking registration by transferee.
- (v) Transferee to duly account for the stocks & capital goods received in books of accounts.

The analysis of above provision in a pictorial form is summarised as follows:

ITC: Change in Constitution of registered Person

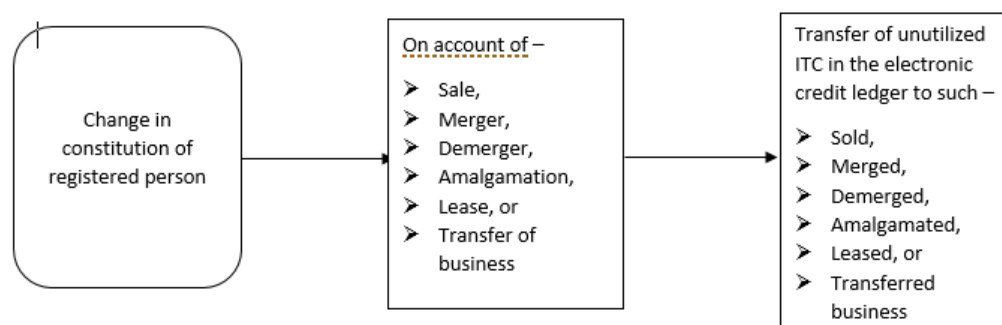

Supply of capital goods on which input tax credit is taken: The registered person shall pay an amount equal to the higher of:

- Input tax credit taken on such capital goods as reduced by such prescribed percentage points or
- the tax on the transaction value of such capital goods,

One striking difference becomes evident in Rule 40 in the manner of computation of ITC in respect of used capital goods under sub rule (1a) and sub rule (2). While sub rule (1a) deals with availment of input tax credit on capital goods after reducing “five percentage points **per quarter of a year** or part thereof”, sub rule (2) specifies computation of input tax credit by reducing “ five percentage points **for every quarter or part thereof** from the date of the issue of the invoice”.

From the above we may come to the following conclusion:

- For the purpose of sub-rule (1a), quarter shall mean a ‘calendar quarter’
- For the purpose of sub-rule (2), the quarter shall be computed from the date on the invoice.
- For example: a capital good purchased on 25th March, 2018 would be reduced by 5 percentage points for the quarter ending March 2018 for the purpose of sub-rule (1a) while the same assets would be reduced by 5 percentage points for the period ranging between 25.03.2018 to 24.06.2018 and so on.

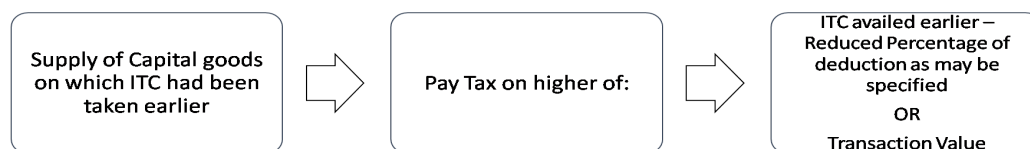
Supply of Capital goods on which ITC already taken

Please note that there is no saving clause in the event the taxable person entertained a *bona fide* view as to the non-taxability of certain supplies or availability of an exemption which is later overturned by a superior Court and the demand crystallizes. In this scenario, limitation of availment of input tax credit lands a double blow to this taxable person. That is, not only would GST have been paid on inputs, input services and capital goods on which no credit would have been availed (due to this *bona fide* view having been entertained) but also, the full extent of the output tax becomes payable (without any relief towards credit that would otherwise have been available) due to the decision of the superior Court. One needs to exercise caution while entertaining a view about non-taxability or exemption. At the same time, it is not permitted to take a hyper-conservative view – where even with the availability of a clear and absolute exemption, the taxable person chooses to pay GST in order to protect credit from the limitation. This option cannot be taken in view of the mandatory nature of such exemptions as clearly stated in explanation to section 11. It could lead to denial of credits as the supply was not taxable!

The difference between ‘taxable person’ and ‘registered person’ is important – they are two deliberately dissimilar phrases used in the law – and credit is allowed u/s 16(1) only to a ‘registered person’ whereas u/s 9(1) tax levied is payable by every ‘taxable person’ implying that the liability subsists even if not registered but credit is available only if registered.

Refractory bricks, moulds and dies, jigs and fixtures are supplied as scrap: Taxable person may pay tax on transaction value under section 15.

18.3 Issues and Concerns

It is important to note that unlike Rule 42 which mandates determination of the actual amount of reversal on the completion of the financial year, Rule 43 does not prescribe any re-computation at the end of the financial year. This could be presumed to be due to the fact that reversal of input tax credits under Rule 43 is based on number of tax periods unlike that of Rule 42. But considering the fact that reversal of common credits under Rule 43 is also based on the proportion of turnover of exempt supplies to the total turnover in the State for that tax period, due consideration should be given to the fact that any shortage of availment of ITC on account of any reason cannot be subsequently availed under Rule 43. On the other hand, any excess credit availed would promptly be subject to scrutiny by the proper officer.

18.4 Comparative review

Aspect	Credit under old regime	Input tax credit under GST regime
Credit on stock-in-hand	Rule 3(2) of CCR Rules, 2004	Specified persons in specified situations are eligible for input tax credit on stock
Credit on sale merger or transfer of business	Rule 10 of CCR Rules, 2004	Specific section covering the sale, merger etc
Reversal on goods becoming exempt	Rule 11(3) of CCR, 2004	To be reversed as per section 18(4)

Statutory Provisions

<p>19. Taking input tax credit in respect of inputs and capital goods sent for job work</p> <p>(1) <i>The “principal” shall, subject to such conditions and restrictions as may be prescribed, be allowed input tax credit on inputs sent to a job worker for job work.</i></p> <p>(2) <i>Notwithstanding anything contained in clause (b) of sub-section (2) of section 16, the “principal” shall be entitled to take credit of input tax on inputs even if the inputs are directly sent to a job worker for job-work without being first brought to his place of business.</i></p> <p>(3) <i>Where the inputs sent for job-work are not received back by the “principal” after completion of job-work or otherwise or are not supplied from the place of business of the job worker in accordance with clause (a) or clause (b) of sub-section (1) of section 143 within one year of being sent out, it shall be deemed that such inputs had been supplied by the principal to the job worker on the day when the said inputs were sent out:</i></p> <p><i>Provided that where the inputs are sent directly to a job worker, the period of one year shall be counted from the date of receipt of inputs by the job worker.</i></p> <p>(4) <i>The “principal” shall, subject to such conditions and restrictions as may be prescribed, be allowed input tax credit on capital goods sent to a job-worker for job-work.</i></p> <p>(5) <i>Notwithstanding anything contained in clause (b) of sub-section (2) of section 16, the “principal” shall be entitled to take credit of input tax on capital goods even if the capital goods are directly sent to a job worker for job-work without being first brought to his place of business.</i></p> <p>(6) <i>Where the capital goods sent for job-work are not received back by the “principal” within a period of three years of being sent out, it shall be deemed that such capital goods had been supplied by the principal to the job worker on the day when the said capital goods were sent out:</i></p>
--

Provided that where the capital goods are sent directly to a job worker, the period of three years shall be counted from the date of receipt of capital goods by the job worker.

- (7) *Nothing contained in sub-section (3) or sub-section (6) shall apply to moulds and dies, jigs and fixtures, or tools sent out to a job-worker for job-work.*

Explanation. —For the purpose of this section, “principal” means the person referred to in section 143

Extract of the CGST Rules, 2017

45. Conditions and restrictions in respect of inputs and capital goods sent to the job worker.

- (1) *The inputs, semi-finished goods or capital goods shall be sent to the job worker under the cover of a challan issued by the principal, including where such goods are sent directly to a job-worker.*
- (2) *The challan issued by the principal to the job worker shall contain the details specified in rule 55.*
- (3) *The details of challans in respect of goods dispatched to a job worker or received from a job worker or sent from one job worker to another during a quarter shall be included in FORM GST ITC-04* furnished for that period on or before the twenty-fifth day of the month succeeding the said quarter [or within such further period as may be extended by the Commissioner by a notification in this behalf:*

Provided that any extension of the time limit notified by the Commissioner of State tax or the Commissioner of Union territory tax shall be deemed to be notified by the Commissioner.]

- (4) *Where the inputs or capital goods are not returned to the principal within the time stipulated in section 143, it shall be deemed that such inputs or capital goods had been supplied by the principal to the job worker on the day when the said inputs or capital were sent out and the said supply shall be declared in FORM GSTR-1* and the principal shall be liable to pay the tax along with applicable interest.*

Explanation.- *For the purposes of this Chapter,-*

- (1) *the expressions “capital goods” shall include “plant and machinery” as defined in the Explanation to section 17;*
- (2) *for determining the value of an exempt supply as referred to in sub-section (3) of section 17-*
- (a) *the value of land and building shall be taken as the same as adopted for the purpose of paying stamp duty; and*
- (b) *the value of security shall be taken as one per cent. of the sale value of such security.*

Relevant circulars, notifications, clarifications issued by Government:

1. Chapter Nineteen of the compilation of the GST Flyers as issued by the CBIC on 'Input Tax Credit Mechanism in GST'
2. Chapter Twenty Seven of the compilation of the GST Flyers as issued by the CBIC on 'Job Work under GST'
3. Circular No. 38/2018 dated 26.03.2018 issued by CBIC being clarifications on issues related to Job Work

Related Provisions of the Statute:

Section or Rule	Description
Section 16	Eligibility and conditions for taking input tax credit
Section 143	Job work procedure
Rule 55	Transportation of goods without issue of invoice

19.1 Introduction

This provision relates to availment of credit of input tax on goods sent for job work.

19.2 Analysis**(i) Relevant Definitions:**

- **Job work:** Any treatment or process undertaken by a person on goods belonging to another registered person (section 2(68)).
- **Job worker:** A person who undertakes any treatment or process on goods belonging to another registered person.
- **Principal:** A person on whose behalf an agent carries on the business of supply or receipt of goods or services or both.

(ii) Entitlement of credit on inputs: The principal can take credit of input tax on inputs sent to job-worker subject to fulfilment of the following conditions:

- Rule 45 of Central Goods and Service Tax Rules, 2017 provides the following:
 - To issue a delivery challan for transfer of inputs to the job-worker including where they are sent directly (to maintain paper trail of transaction)
 - The details of delivery challans for goods dispatched to job worker or received from job worker or sent from one job worker to another during the quarter are to be included in Form GST ITC-04 to be furnished on or before 25th day of the month succeeding that quarter. Date of filing ITC-04 has however been extended from time to time.
 - Delivery challan is to contain all details as required in respect of an invoice prescribed in Rule 55 of Central Goods and Service Tax Rules, 2017. All delivery

challans issued in respect of inputs sent to a job-worker and those received back are to be reported in GSTR-1

- The inputs, after completion of job-work, are to be received back by the principal within 1 year of their being sent out.
- In case of non-receipt of the inputs within the time prescribed, the principal shall issue an invoice for the same and declare such supplies in his return for that particular month in which the time period of one year has expired.
- In case of direct supply, the period of 1 year shall be reckoned from the date the job worker receives such inputs.
- The credit of inputs can be taken even if inputs are sent directly to job-worker's premises without bringing it to principal's place of business.
- If the inputs are not received back within 1 year, it shall be deemed that such inputs had been supplied by principal to the job worker on the day when the said inputs were sent out.

(iii) Entitlement to credit on capital goods: The principal can take credit of input tax on capital goods sent to job-worker subject to the fulfilment of the following conditions:

- The capital goods, after completion of job-work, are received back by him within 3 years of their being sent out.
- The principal can take credit of capital goods even if such capital goods are sent directly to job-worker's place without bringing to principal's place of business.
- If the capital goods are not received back within 3 years, it shall be deemed that such capital goods had been supplied by principal to the job worker on the day when the said capital goods were sent out.
- Procedures listed in respect of inputs under Rule 45 of the Central Goods and Service Tax Rules, 2017 will equally apply to capital goods also (refer above).

Given that non-receipt of inputs or capital goods within a period of one year and three years respectively would be deemed to be a supply as on the date on which goods were originally dispatched to the job worker, it is preferred that a principal raises a tax invoice and supplies the goods against such invoice at the time of original supply, if he is certain that such goods would not be received within the period specified above. This would enable the principal from having to bear the burden of interest, as interest would be calculated from the date on which the goods were originally dispatched and not from the date on which the period of one year or three years, as the case may be, expires.

Some experts are of the view that unless the Principal is 'registered', the activity would not be 'job-work'. And when the supply – treatment or process – is not job-work, then it would also not be eligible to be classified under HSN 9988 in the Annexure – Scheme of Classification of Services. Although the nature of work performed is the same whether the Principal is registered or not, the classification of supplies would need to be based on another suitable

HSN code in chapter 99 because paragraph 3, Schedule II does refer to 'another person's goods' and not 'another registered person's goods'. Hence, due to the registration status of the Principal, the treatment or process may or may not qualify as job-work but in either case, the work of the supplier would continue to be 'treated as supply of services' though not under HSN 9988. It must be noted that while every manufacture may encompass 'process or job-work' every job-work need not necessarily result in manufacture. It is for this reason that in the rate notification manufacturing services has been separately mentioned for work carried out on "physical inputs owned by others".

Treatment of process undertaken may or may not result in manufacture (section 2(72)) where processing of raw material or inputs that results in the emergence of a new product. Whether it results in manufacture or not, the treatment or process would always be 'treated as supply of services' in view of the mandate specified in paragraph 3, schedule II.

Now, 'goods belonging to another' does not mean 100% of the goods required in the job-work must be provided by the Principal. It is common, and often inevitable, for the job-worker to apply his own goods. Goods required for job-work can generally be identified as primary, secondary and ancillary material. If the job-worker applies ancillary material in the course of carrying out the treatment or process, the transaction does not cease to be job-work. Similarly, if the Principal provides only ancillary material, it is not justifiable to regard the transaction as job-work. Hence, a reasonable construction of the definition of paragraph 3, schedule II requires the Principal to provide the 'primary material' at least to qualify a transaction to be termed as 'job work'. Although there are no infallible tests or undisputed guiding principle or no one-rule can be prescribed -the classification into primary-secondary-ancillary itself is a subjective matter. Reasonable construction is required based on the role, each component plays in relation to the finished product in terms of function and identity to determine 'goods belonging to another' correctly.

Please note that job-working must not be confused with repair or maintenance. Job-working creates the functionality of an article but repair or maintenance restores or improves the functionality already created and possessed by that article or thing.

As regards 'movement of goods' by Principal to job-worker, it is not a supply for the reason that the ingredients required to constitute supply (as detailed in the explanation of clause (a) to (c) under section 7(1)) are not satisfied. It is for this reason that section 19(3) and 19(6) is required to 'deem' this movement of goods to be a supply in the event of failure of job-worker to return processed goods within the permitted time (1 year for inputs and 3 years for capital goods, respectively). Further, 19(3) and 19(6) 'deem' it to be a supply not on the date of expiry of the permitted time to return them, but retrospectively on the date when the inputs / capital goods were originally sent 'for' job-work.

Deeming fiction is capable of providing a meaning that is otherwise not available to a work or phrase. Deeming fiction is used with great caution by the law-maker and when it is used, its construction must be with the same caution and seriousness. Hence, 'movement of goods' for

the purpose of job-work is not supply but is 'deemed' to be a supply by failure of a contingency or condition-subsequent.

It is section 16 and not section 19 that allows input tax credit, but section 19 permits availment of input tax credit even when the inputs (or capital goods) are not first received at the premises of the Principal but delivered directly to job-worker. Section 19 also does not deny or recover the input tax credit already availed by the Principal on the occasion of sending them to the job-worker. When movement of goods for job-work is not a supply, where is the need for a provision to permit continuation of credit that was already availed validly. Since credit has been availed, failure to use the inputs (or capital goods) as 'intended' under section 16(1) would cause a break-down of the credit scheme – to allow credit only when the said goods are subsequently supplied and are taxable. And for this reason, transfer of business assets on which credit availed is 'declared' to be supply in paragraph 1, schedule I and diversion for non-business use (in certain cases) is 'treated' as supply in paragraph 4(a) and 4(b), schedule II. But there is no provision to impute supply characteristics to 'movement of goods for job-work'. This responsibility is cast by section 19(3) and 19(6), respectively.

This can be contrasted with the 'time of supply' of goods sent-on-approval under section 31(7). Here, the date of acceptance by customer (or end of 6th month) is recognized as supply and hence registers 'time of supply'. It is interesting to note that there is deeming fiction employed here because none is required. In other words, 'sending goods on approval' is not a supply for the same reason that the ingredients required to constitute supply (as detailed in the explanation of clause (a) to (c) under section 7(1)) are not satisfied. And such a test can validly be applied for verifying whether 'movement of goods for job-work' is supply or not. By applying the same test to 'sending goods on approval', the 'time of supply' is not the date of sending them but the date of their acceptance by customer (or end of 6th month).

19.3 Comparative review

Aspect	Credit under erstwhile system	Input tax credit under CGST
Definition of "job work"	Defined in Cenvat Credit Rules to mean processing of material supplied to job worker to complete whole or part of manufacturing process	Defined to mean undertaking any treatment or process by a person on goods belonging to another registered person
Eligibility of Cenvat credit to principal manufacturer	Principal is eligible for Cenvat credit	Similar in CGST. Principal is eligible for Cenvat credit
Conditions for return of inputs and capital goods	For inputs – 180 days For capital goods – 2 years	For inputs – 1 year For capital goods – 3 years
Reversal of credit if inputs/capital goods not	Credit to be reversed	To be treated as deemed supply on the day when

returned within specified time		such inputs/capital goods are sent out
Re-credit if goods returned after specified time	Re-credit allowed	No such provision

19.4 FAQs

Q1. Whether the principal is eligible to avail input tax credit of inputs sent to job worker for job work?

Ans. Yes. The principal is eligible to avail the input tax credit on inputs sent to job worker for job work.

19.5 MCQs

Q1. The inputs sent to job work has to be received back within:

- (a) 1 year
- (b) 2 years
- (c) 180 days

Ans. (a) 1 year.

Q2. The principal is entitled to avail the credit on capital goods sent to job worker directly:

- (a) Yes
- (b) No
- (c) May be

Ans. (a) Yes.

Q3. If the capital goods sent to job worker has not been received within 3 years from the date of being sent:

- (a) Principal has to pay amount equal to credit taken on such capital goods
- (b) No need to pay amount equal to credit taken on such capital goods
- (c) It shall be treated as deemed supply of capital goods to the job worker
- (d) None of the above

Ans. (c) It shall be treated as deemed supply of capital goods to the job worker

Statutory provisions**20. Manner of distribution of credit by Input Service Distributor**

(1) *The Input Service Distributor shall distribute the credit of central tax as central tax or integrated tax and integrated tax as integrated tax or central, by way of issue of a document*

containing, the amount of input tax credit being distributed in such manner as may be prescribed.

(2) The Input Service Distributor may distribute the credit subject to the following conditions, namely:

- (a) the credit can be distributed to recipients of credit against a document containing such details as may be prescribed;
- (b) the amount of the credit distributed shall not exceed the amount of credit available for distribution;
- (c) the credit of tax paid on input services attributable to recipient of credit shall be distributed only to that recipient;
- (d) the credit of tax paid on input services attributable to more than one recipient of credit shall be distributed amongst such recipient(s) to whom the input service is attributable and such distribution shall be pro rata on the basis of the turnover in a State or turnover in a Union Territory of such recipient, during the relevant period, to the aggregate of the turnover of all such recipients to whom such input service is attributable and which are operational in the current year, during the said relevant period;.
- (e) the credit of tax paid on input services attributable to all recipients of credit shall be distributed amongst such recipients and such distribution shall be pro rata on the basis of the turnover in a State or turnover in a Union Territory of such recipient, during the relevant period, to the aggregate of the turnover of all recipients and which are operational in the current year, during the said relevant period.

Explanation –For the purposes of this section,

- (a) the “relevant period” shall be-
 - (i) if the recipients of credit have turnover in their States or Union Territories in the financial year preceding the year during which credit is to be distributed, the said financial year; or
 - (ii) if some or all recipients of the credit do not have any turnover in their States or Union Territories in the financial year preceding the year during which the credit is to be distributed, the last quarter for which details of such turnover of all the recipients are available, previous to the month during which credit is to be distributed.
- (b) the expression of ‘recipient of credit’ means the supplier of goods or services or both having the same Permanent Account Number as that of Input Service Distributor.
- (c) the term ‘turnover’ in relation to any registered person engaged in the supply of taxable goods as well as goods not taxable under this Act, means the value of

*turnover, reduced by the amount of any duty or tax levied **under entries 84 and entry 92A**³ of List I of the Seventh Schedule to the Constitution and entry 51 and 54 of List II of the said Schedule*

Extract of the CGST Rules, 2017

39. Procedure for distribution of input tax credit by Input Service Distributor

(1) An Input Service Distributor shall distribute input tax credit in the manner and subject to the following conditions, namely, -

- (a) the input tax credit available for distribution in a month shall be distributed in the same month and the details thereof shall be furnished in FORM GSTR 6* in accordance with the provisions of Chapter VIII of these rules;
- (b) the Input Service Distributor shall, in accordance with the provisions of clause (d), separately distribute the amount of ineligible input tax credit (ineligible under the provisions of sub-section (5) of section 17 or otherwise) and the amount of eligible input tax credit;
- (c) the input tax credit because central tax, State tax, Union territory tax and integrated tax shall be distributed separately in accordance with the provisions of clause (d);
- (d) the input tax credit that is required to be distributed in accordance with the provisions of clause (d) and (e) of sub-section (2) of section 20 to one of the recipients 'R1', whether registered or not, from amongst the total of all the recipients to whom input tax credit is attributable, including the recipient(s) who are engaged in making exempt supply, or are otherwise not registered for any reason, shall be the amount, "C₁", to be calculated by applying the following formula –

$$C_1 = (t_1 \div T) \times C$$

where,

"C" is the amount of credit to be distributed,

"t₁" is the turnover, as referred to in section 20, of person R₁ during the relevant period, and

"T" is the aggregate of the turnover, during the relevant period, of all recipients to whom the input service is attributable in accordance with the provisions of section 20;

- (e) the input tax credit on account of integrated tax shall be distributed as input tax credit of integrated tax to every recipient;
- (f) the input tax credit on account of central tax and State tax or Union territory tax shall
 - (i) in respect of a recipient located in the same State or Union territory in which the

³ Inserted vide The Central Goods and Services Tax Amendment Act, 2018 w.e.f. 01.02.2019

- Input Service Distributor is located, be distributed as input tax credit of central tax and State tax or Union territory tax respectively;
- (ii) in respect of a recipient located in a State or Union territory other than that of the Input Service Distributor, be distributed as integrated tax and the amount to be so distributed shall be equal to the aggregate of the amount of input tax credit of central tax and State tax or Union territory tax that qualifies for distribution to such recipient in accordance with clause (d);
 - (g) the Input Service Distributor shall issue an Input Service Distributor invoice, as prescribed in sub-rule (1) of rule 54, clearly indicating in such invoice that it is issued only for distribution of input tax credit;
 - (h) the Input Service Distributor shall issue an Input Service Distributor credit note, as prescribed in sub-rule (1) of rule 54, for reduction of credit in case the input tax credit already distributed gets reduced for any reason;
 - (i) any additional amount of input tax credit on account of issuance of a debit note to an Input Service Distributor by the supplier shall be distributed in the manner and subject to the conditions specified in clauses (a) to (f) and the amount attributable to any recipient shall be calculated in the manner provided in clause (d) and such credit shall be distributed in the month in which the debit note is included in the return in FORM GSTR-6*;
 - (j) any input tax credit required to be reduced on account of issuance of a credit note to the Input Service Distributor by the supplier shall be apportioned to each recipient in the same ratio in which the input tax credit contained in the original invoice was distributed in terms of clause (d), and the amount so apportioned shall be
 - (i) reduced from the amount to be distributed in the month in which the credit note is included in the return in FORM GSTR-6*; or
 - (ii) added to the output tax liability of the recipient where the amount so apportioned is in the negative by the amount of credit under distribution being less than the amount to be adjusted.
 - (2) If the amount of input tax credit distributed by an Input Service Distributor is reduced later for any other reason for any of the recipients, including that it was distributed to a wrong recipient by the Input Service Distributor, the process specified in clause (j) of sub-rule (1) shall apply, mutatis mutandis, for reduction of credit.
 - (3) Subject to sub-rule (2), the Input Service Distributor shall, on the basis of the Input Service Distributor credit note specified in clause (h) of sub-rule (1), issue an Input Service Distributor invoice to the recipient entitled to such credit and include the Input Service Distributor credit note and the Input Service Distributor invoice in the return in FORM GSTR-6* for the month in which such credit note and invoice was issued.

Relevant circulars, notifications, clarifications issued by Government:

1. Chapter Nineteen of the compilation of the GST Flyers as issued by the CBIC on 'Input Tax Credit Mechanism in GST'
2. Chapter Ten of the compilation of the GST Flyers as issued by the CBIC on 'Input Service Distributor in GST'

Related Provisions of the Statute

Section or Rule	Description
Section 2(61)	Definition of 'Input Service Distributor'
Section 16	Eligibility and conditions for taking input tax credit
Section 17	Apportionment of credit and blocked credits
Rule 54	Tax invoice in special cases
Rule 65	Form and manner of submission of return by an Input Service Distributor

20.1 Introduction

This Section sets forth the way input tax credit (of services) is distributed to supplier of goods or services or both of same entity having same PAN. Procedure for distribution is given in Rule 39 of Central Goods and Service Tax Rules, 2017.

20.2 Analysis

- (i) An ISD shall distribute the eligible ITC in accordance with Rule 39 elucidated in the following paras.
- (ii) Input Service Distributor (ISD) is an office of the supplier of goods or services or both where a document (like invoice) of services attributable to other locations are received (since they might be registered separately). Since the services relate to other locations the corresponding credit should be transferred to such locations (having separate registrations) as services are supplied from there. Care should be taken to ensure that an inter-branch supply of services should not be misinterpreted as a distribution by ISD. Please recollect that ISD cannot be an office that does any supply of its own but must be one that merely collects invoice for services and issues prescribed document for its distribution.
- (iii) ISD cannot normally be used in a situation where there is a liability to pay GST. It can only receive input tax credits on invoices related to input services and distribute such credits in the manner discussed below. An ISD cannot discharge tax liability under reverse charge. This would require obtaining another registration as a regular registered person and discharge RCM liability.

Examples hereunder are as per rules.

Illustration: Corporate office of XYZ company Ltd., is at New Delhi, having its business locations of selling and servicing of goods at New Delhi, Chennai, Mumbai and Kolkata. For example, if the software license and maintenance is used at all the locations, invoice indicating CGST and SGST is received at Corporate Office. Since the software is used at all the four locations, the input tax credit of entire services cannot be claimed at New Delhi. The same has to be distributed to all four locations. For that reason, the Delhi Corporate office has to act as ISD to distribute the credit.

Rule 39: Central Goods and Service Tax Rules, 2017

The example provided below illustrates the application of Rule 39 of the Central Goods and Service Tax Rules, 2017 for distribution of credits by an Input Service Distributor (ISD) in terms of Section 20.

Yoko Infotech Ltd. has its head office in Mumbai, for which it additionally has an ISD registration. The company has 12 units across India including its head office. It receives the following invoices in the name of the ISD at Mumbai, for the month of January 2018:

Invoice A: ₹ 100,000 @ **IGST** 18,000 issued by Peace Link Technologies (registered in Uttar Pradesh) for repairs executed in 3 units – **Bangalore, Kolkata, Gurgaon** (Note: Gurgaon location is not registered as it is engaged in making only exempt supplies);

Invoice B: ₹ 300,000 @ **CGST** 27,000, **SGST** 27,000 issued by M/s. Tec Force (registered in Pune) for repairs executed in 3 units – **Mumbai, Bangalore, Kolkata**;

Invoice C: ₹ 500,000 @ **IGST** 90,000 issued by M/s. Georgia Marketing (registered in Bangalore) for marketing services for the **company**;

Invoice D: ₹ 10,000 @ **CGST** 900 & **SGST** ₹900 issued by M/s. Gopal Coffee works (registered in Mumbai) for supply of beverages during the month to its **Mumbai unit**.

All taxes have been considered at 18% (CGST and SGST at 9% each).

The turnover of each of the units during the year 2016-17 is: Mumbai: 1 crore; Bangalore 2 crore; Kolkata 1 crore; Gurgaon 2 crore; each of the other 8 units: 50 lakhs, resulting in the aggregate turnover of the company in the previous financial year, of 10 crores.

Distribution of credits by the ISD:

Particulars	Invoice	Bangalore	Kolkata	Mumbai	Gurgaon	8 units	Total
Invoice A							
T/o in State	Note 1	2 crore	1 crore	-	2 crore	-	5 crore
Pro-rata ratio		40%	20%	-	40%	-	100%
Credit	18,000	7,200	3,600	-	7,200	-	18,000
Type	IGST	IGST	IGST	-	IGST	-	

Invoice B							
T/o in State	Note 2	2 crore	1 crore	1 crore	-	-	4 crore
Pro-rata ratio		50%	25%	25%	-	-	100%
CGST Credit	27,000						
• Distribution		13,500	6,750	6,750	-	-	27,000
Type	CGST	IGST	IGST	CGST	-	-	
SGST Credit	27,000						
• Distribution		13,500	6,750	6,750	-	-	27,000
Type	SGST	IGST	IGST	SGST	-	-	
Invoice C							
T/o in State	Note 3	2 crore	1 crore	1 crore	2 crore	0.5 * 8 crore	10 crore
Pro-rata ratio		20%	10%	10%	20%	5% * 8 units	100%
Credit	90,000	18,000	9,000	9,000	18,000	4,500 * 8 units	90,000
Type	IGST	IGST	IGST	IGST	IGST	IGST	
Invoice D							
Attributable to	Note 4	-	-	Yes	-	-	-
Credit (ineligible)	900	-	-	900	-	-	900
Type	CGST	-	-	CGST	-	-	
Credit (ineligible)	900	-	-	900	-	-	900
Type	SGST	-	-	SGST	-	-	
Credit of CGST, SGST and IGST on invoice		Total eligible credits distributed as CGST, SGST and IGST as applicable (Refer Note below)					
CGST	27,000	-	-	6,750	-	-	6,750

SGST	27,000	-	-	6,750	-	-	6,750
IGST	108,000	52,200	26,100	9,000	25,200	4,500 each (viz. total of 36,000)	148,500
TOTAL	162,000	52,200	26,100	22,500	25,200	36,000	162,000

It can be seen from the illustration that credit of CGST of ₹ 27,000 is distributed as CGST credit only to the extent of ₹ 6,750; likewise, credit of SGST of ₹ 27,000 is distributed as SGST credit only to the extent of ₹ 6,750. This is because, the intra-State service billed to the ISD is attributable to 1 unit in the same State as the ISD and 2 other units located in different State. Thus, the balance of CGST credit and SGST credit is distributed as IGST to such units. This is the reason why the credit of IGST lying with the ISD prior to distribution is only ₹ 108,000 while the credit of IGST that is distributed aggregates to ₹ 148,500.

Note 1: The credit of IGST should always be distributed as IGST credit to all the units to which the service is attributable, regardless of where they are located.

- The credits should be distributed only to those units to which the service is attributable. Given that the service mentioned in the case of Invoice A is attributable only to Bangalore, Kolkata and Gurgaon, the entire input tax credit applicable to the case should be distributed to the said 3 units, on a pro rata basis in the ratio of their respective 'Turnover in State' to the aggregate of the 3 'Turnover in State' (i.e., 2 Cr + 1Cr + 2 Cr). Further, no differentiation is made to whether the unit is registered or not, and therefore, credit attributable to the Gurgaon unit is distributed to that unit although it is not registered, which implies, it is a loss of credit.
- The 'turnover in State' is arrived at a value for the 'relevant period'. Since all 12 units were operational during the preceding financial year, the relevant period would be the preceding financial year.

Note 2: The credit of CGST and SGST should be distributed as IGST credit to all the units located outside the State in which the ISD is located, and as CGST and SGST respectively, in case of distribution of credit to a unit located in the same State as the ISD. Thus, the CGST and SGST credits are distributed as IGST credits to Bangalore and Kolkata, and as CGST & SGST respectively, to Mumbai.

- Given that the service supplied in terms of Invoice B is attributable only to Bangalore, Kolkata and Mumbai, the entire input tax credit applicable to the case should be distributed to the said 3 units, on a pro rata basis in the ratio of their respective 'Turnover in State' to the aggregate of the 3 'Turnover in State' (i.e., 2 Cr + 1Cr + 1 Cr).

Note 3: The credit of IGST is distributed as IGST to all the units to which the service is attributable.

- Invoice C relates to a supply of service that is attributable to all the units, and hence,

the credits would be distributed on a pro-rata basis of the 'Turnover in State' of each of the units, to the aggregate of 'Turnover in State' of all the 12 units, i.e., ₹10 Cr.;

- For convenience of presentation, only one column is shown to reflect the distribution to each of the 8 units, having the same 'turnover in State', and to which the same invoice is attributable.

Note 4: Given that the services for receipt of food and beverages would not be eligible input services, the taxes relating to Invoice D should be distributed as ineligible input tax (900 + 900), and the distribution must be done separately.

Since the service is wholly attributable to the Mumbai unit, the distribution is done only to such unit.

- (iv) **Distribution of credit where ISD and recipient are located in different States under CGST Act:** As per Rule 39(1)(e) and (f) of Central Goods and Service Tax Rules, 2017 ISD shall distribute as prescribed, credit of CGST as CGST or IGST and credit of IGST as IGST by issuing prescribed document mentioning the amount of credit distributed to recipient of credit located in different States.

Illustration: In the above illustration, if the corporate office of XYZ Ltd being an ISD situated in Delhi receives invoices indicating ₹ 4 lakhs of CGST in one service and ₹ 7 lakhs as of IGST in another case. It shall distribute CGST of ₹ 4 Lakhs IGST and credit of IGST of ₹ 7 Lakhs also as IGST to its locations at Chennai, Mumbai and Kolkata under a prescribed document containing the amount of credit distributed.

- (v) **Distribution of credit where ISD and recipient are located in different States under SGST Act:** ISD could distribute as prescribed credit of SGST as IGST only (and not as SGST of other State) by issuing a prescribed document containing the amount of credit distributed.

Illustration: In the above illustration, corporate office of XYZ Ltd., also received SGST of ₹ 6 Lakhs along with ₹ 4 Lakhs of CGST. It can distribute SGST credit as IGST to its locations at Chennai, Mumbai and Kolkata under a prescribed document containing the amount of credit distributed.

- (vi) **Distribution of credit where ISD and recipient are located within the State under CGST Act:** In cases where an entity has different registration within the same State by an entity, it may have to distribute credit to such location also similar to locations with different registrations outside the State. In order to enable the same, it is provided that ISD can distribute in the prescribed manner, credit of CGST as CGST and credit of IGST as IGST by issuing prescribed document mentioning the amount of credit distributed to recipient being a business vertical.

Illustration: ABC Ltd., having its office at Bangalore is having another business vertical in Mysore which is separately registered. In such a case, out of input tax credit of ₹ 4 lakhs of CGST, the credit attributable to ABC Ltd, Bangalore, shall be distributed to

Mysore location as CGST. Similarly out of input tax credit of ₹ 10 Lakh of IGST, the credit attributable to ABC Ltd, Bangalore shall be distributed to Mysore location as IGST.

- (vii) **Distribution of credit where ISD and recipient are located within the State under SGST Act:** Similar to the provisions of CGST as indicated supra under CGST Act, even under the SGST Act, it is provided that an ISD can distribute in the prescribed manner, credit of SGST and IGST as SGST (of the same State and not other State) and IGST respectively, by issuing a prescribed document mentioning the amount of credit distributed to recipient being a business vertical.

Illustration: In the same example of ABC Ltd., above the input tax credit say ₹ 6 lakhs of SGST shall be distributed as SGST.

- (viii) **Conditions to distribute credit by ISD:** The conditions to distribute the credit by ISD are as follows:
- Credit to be distributed to recipient under prescribed documents containing prescribed details. Such document should be issued to each of the recipient of credit.
 - Credit distributed should not exceed the credit available for distribution.
 - Tax paid on input services used by a particular location (registered as supplier), is to be distributed only to that location.
 - Credit of tax paid on input service used by more than one location who are operational is to be distributed to all of them based on the pro rata basis of turnover of each location in a State to aggregate turnover of all such locations who have used such services.

Note: The period to be considered for computation is the previous financial year of that location. If it does not have any turnover in the previous financial year, then previous quarter of the month to which the credit is being distributed.

- (ix) For a detailed discussion on Tax invoice or Credit note to be issued by an ISD reference maybe made to Chapter VII. The said Chapter VII clearly indicates the particulars to be included in such a document.

Illustration 1: A Ltd as an ISD has input service credit of ₹ 35 lakhs used by more than one locations, to be distributed among recipients locations X, Y and Z. The turnover of X, Y, Z in preceding financial year, is ₹ 10 crores, ₹ 15 crores and ₹ 5 crores respectively. The credit of ₹ 5 lakhs pertains to input service received only by Z. The credit attributable to X, Y, Z are as follows:

Particulars	Amount (in ₹)
Total Credit to be distributed as ISD	35 Lakhs
Credit of service used only by Z location	5 Lakhs

Credit available for distribution for all units	30 Lakhs
Credit distributable to X 10 crores / 30 crores * 30 Lakhs	10 Lakhs
Credit distributable to Y 15 crores / 30 crores * 30 Lakhs	15 Lakhs
Credit distributable to Z 5 crores / 30 crores * 30 Lakhs = 5 Lakhs Credit directly attributable to Z = 5 Lakhs	10 Lakhs

Illustration 2: Distribution of input tax credit by an ISD to its units is shown as under:

M/s XYZ Ltd, having its head Office at Delhi, is registered as ISD. It has three units in different State namely 'Delhi', 'Jaipur' and 'Gujarat' which are operational in the current year. M/s XYZ Ltd furnishes the following information for the month of July 2018 & asks to distribute the credit to various units.

- (i) CGST paid on services used only for Delhi Unit: ₹ 300000/-
- (ii) IGST, CGST & SGST paid on services used for all units: ₹ 1200000/-
- (iii) Total Turnover of the units for the Financial Year 2017-18 are as follows:-

Unit	Turnover (₹)
Delhi	5,00,00,000
Jaipur	3,00,00,000
Gujarat	2,00,00,000
Total	10,00,00,000

Solution: Computation of Input Tax Credit Distributed to various units: -

Particulars	Total Credit Available	Delhi	Jaipur	Gujarat
		Credit distributed to all Units		
CGST paid on services used only for Delhi Unit.	300000	300000	0	0
IGST, CGST & SGST paid on services used in all units- Distribution on pro rata basis to all the units which are operational in the current year (Refer Note1)	1200000	600000	360000	240000
Total	1500000	900000	360000	240000

Note 1: Credit distributed pro rata basis based on the turnover of all the units are as under: -

- (a) Unit Delhi: $(50000000/100000000)*1200000 = ₹ 600000$
- (b) Unit Jaipur: $(30000000/100000000)*1200000 = ₹ 360000$
- (c) Unit Gujarat: $(20000000/100000000)*1200000 = ₹ 240000$

Relevant period for distribution of credit:

- (a) If the recipient of credit has turnover in their State in preceding financial year of the year in which credit is distributed – Such financial year.
- (b) If some or all recipients do not have any turnover in their State in preceding financial year of the year in which credit is distributed – Last quarter for which details of such turnover of all the recipients are available, previous to the month during which credit is to be distributed.

The analysis of above provision in a pictorial form is summarised as follows:

Input Service Distributor – Sec. 20.

- ITC is distributed to supplier of goods or services or both of same entity having the same PAN as the ISD
- Common Services used at for

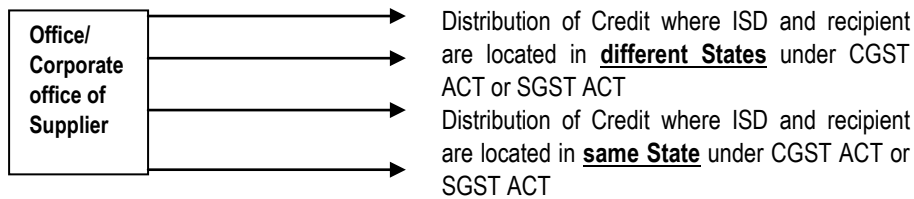

Input Service Distributor

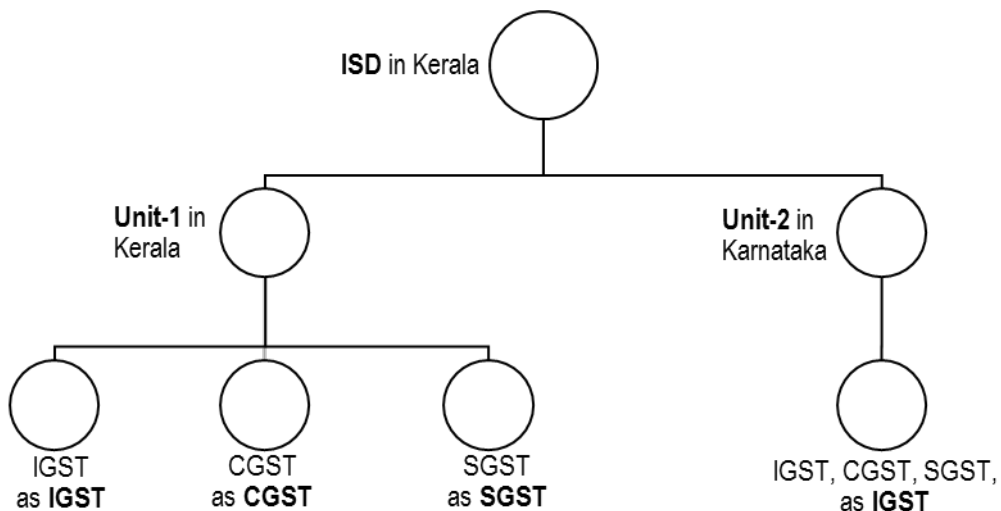

Illustration 3: Consider an example where a Company has a Branch-M in Mumbai and a Branch-D in Delhi. This Company is also incorporated in Delhi. Branch-M incurs various expenses that are supply of services in Delhi where CGST-SGST is liable to be charged in Delhi by that supplier. Obviously, credit of this tax cannot be availed by Branch-D because the underlying expense is not 'in relation to business' of Branch-D because it is exclusively in relation to business of Branch-M. When credit cannot be claimed by Branch-D and Branch-M does not want to forego this credit, the option available is for Branch-M to obtain ISD registration in Delhi. Now, in exactly, the same manner, if Branch-M incurs expenses in Maharashtra (say in Nasik), the implications would be that credit not allowable to Branch-M for these supplies and Branch-D is eligible to obtain ISD registration in Maharashtra, if credit is not to be foregone.

From this example, the following questions arise for careful consideration:

Question	Response
(i) Is ISD registration required in 'all but one' States for a registered taxable person? (All but one may all States/UT other than Home State)	Yes. If tax charged by the supplier is not IGST but CGST-SGST of the host-State where supplies are taking place, then a registered taxable person would require ISD registration in each those host-States except home-State
(ii) Is ISD registration an entity-level office in a given State or is it a registered taxable persons-specific office in other States (outside the home State of that registered taxable person)?	Yes, ISD is an entity-level office because section 2(61) defines ISD as "... means an office of the supplier which receives tax invoice...." It does not say it is an "office of the registered taxable person which receives tax invoice...."
(iii) Will ISD registration be required for each registered taxable person in 'all but one' States? (All but one may all States/UT other than Home State)	No. One entity-level ISD registration in all States will suffice for credit distribution requirement of all registered taxable persons having same PAN
(iv) Can an ISD distribute credit of taxes paid in that State alone (whether IGST or CGST-SGST) to registered taxable persons in all other States or only to that State for whose benefit the ISD registration was obtained?	Since ISD is an entity-level registration, one ISD in a State can distribute credit to all registered taxable persons in all other States having same PAN. Further, this ISD can also distribute credit to separately registered business verticals in that same State
(v) When GSTIN registration is obtained in	Yes, GSTIN registration does not permit

one State, is there any need to also obtain ISD in the same State or is GSTIN and ISD registrations mutually exclusive in a given State?	distribution of credit. If taxes are paid that is not related to the business of that registered taxable person in that State, then for want of 'nexus', credit cannot be availed by him. And to save from loss of credit, ISD registration is the only option to distribute this credit whichever registered taxable person (called 'recipient of credit') satisfies this nexus test.
(vi) Can a Company who has independent operations in all 29 States and 2 UTs and is therefore registered in all 31 locations also be required to have 31 ISD registrations?	Yes, the Company could opt to do so.. This is because each registered taxable person stated to be truly independent of other business (of registered taxable persons) and receives supplies in those host-States where CGST-SGST paid in those host-States is to be distributed to the relevant home-State
(vii) Is it possible, when GSTIN registration is already available in any given State, for the Company to completely avoid ISD registration?	No, for the reasons stated in (vi) & (i) above, it would not be possible to avoid ISD registration
(viii) If a Company, to avoid ISD compliances, decides to avoid ISD registration in every State where it is already having GSTIN registration?	It is possible that a Company may consider the possibility of doing so subject to loss of legitimate credits which could have been availed as an ISD
(ix) If a Company were to instruct all registered taxable persons in a State who may have credit loss in other States misdirect the suppliers into issuing tax invoice with GSTIN of that State?	Yes, it is possible for a Company to misdirect a supplier. This supplier would only look for genuine GSTIN and similarity of name. It is not the supplier's responsibility to examine 'nexus' while issuing tax invoice
(x) Is ISD registration, therefore, necessary in every State where this 'nexus' test cannot be fulfilled by each registered taxable person?	Yes, as explained in (vii) above, ISD registration is necessary in every State where 'nexus' test is not fulfilled
(xi) Therefore, if multiple ISD registrations or GSTIN-plus-ISD registrations are unavoidable (as explained above), is there any solution to resolve this multiplicity of monthly and quarterly	Yes, only if 'link is established between the 'no nexus' supplies in a State and the registered taxable person in that same State. If no such 'nexus' exists, credit claim by registered taxable person becomes

compliances?	improper. If nexus is established, please examine valuation of inter-branch supply of services is as per proviso to Rule 28 or as per Rule 30 of Central Goods and Service Tax Rules, 2017 relating to Valuation.
--------------	---

ISD is not merely a matter of compliance but involves great revenue implications to a registered taxable person. Compliance would also not be nominal. So, this is yet another indicator that the business model that has been in place until now has reached end-of-life and a new model needs to be examined. Please consider the following example of a CA in practice with branches in 3 States where the facts are as follows:

Common facts for consideration:	
Head office	Maharashtra
Branch offices	West Bengal and Delhi
Client base	All 3 States
Skills based	Distributed in all offices, based on the assignment, staff from all offices join to complete the assignment
Completion	Sign-off only by Partners who are in Maharashtra and West Bengal

Business models and their comparison are as follows:

Criteria	Under Erstwhile Law	Under GST Law – A	Under GST Law – B
ST (GST) registration	Centralized at Mumbai	All 3 branches	All 3 branches
Billing to clients	From all 3 offices	From Mumbai only	From all 3 offices
Internal billing	None	Branches issue tax invoice to HO at 'cost plus 10%' as per Rule 30 of Central Goods and Service Tax Rules, 2017 relating to Valuation	Every branch including HO to bill each other for their respective contribution on 'revenue split' or 'proportion of contribution' method
ST credit of branches	Availed at Mumbai due to centralized registration (ISD registration not required)	Branches and HO avail input tax credit on tax invoices issued by respective suppliers	Branches and HO avail input tax credit on tax invoices issued by respective suppliers including internal bills

ST credit at HO	Mumbai credits, entity-level credits and branch-specific credits	HO retains credit of all entity-level credits and avails credit of tax invoice issued by branches	HO retains credit of all entity-level credits
Loss, cost or risk	None	IGST outflow on non-credit costs included in valuation and 10% mark-up. Non-credit costs of branches are salaries, depreciation, etc.	Nexus risk on credits: <ul style="list-style-type: none"> entity-level costs like audit fee central vendor bills like data-telecom, travel, etc. Administrative challenge in assignment-level billing allocation
Mitigation	NA	Branch to invoice HO on 30 th in respect of client-level billings due on 1 st of next month so that the incremental IGST outflow from HO to branches is recovered quickly	GST does not impose any 'one-to-one' correlation of credits. Entity-level credit can be contended to be allowed in HO. Assignment-level billing allocation left to each branch to self-regulate

There is no doubt that the above are not recommendations but case for comparative illustration regarding application of the law to a business and to highlight that it is impossible to continue the erstwhile business model in GST, at least in many sectors.

The illustrations considered in this section are matters to be considered for discussion/deliberations only and are not views envisaged. The reader may or may not agree with the views in the discussion in this Chapter/section.

20.3 Comparative review

These provisions are similar to the provisions contained in the Rule 7 of CENVAT credit rules for distribution of credit of input service by an ISD.

It appears that the distribution of credit among the recipients prescribed in CENVAT credit Rules has been continued in proposed GST law. The conditions for distribution of credit for each recipient also appear to be continued as before.

20.4 FAQs

Q1. Whether CGST and IGST credit can be distributed by ISD as IGST credit to units located in different States?

Ans. Yes. CGST credit can be distributed as IGST and IGST credit can be distributed as IGST by an ISD for the units located in different States.

Q2. Whether SGST credit can be distributed as IGST credit by an ISD to units located in different States?

Ans. Yes. ISD can distribute SGST credit as IGST for the units located in different States.

Q3. What are the conditions to be fulfilled by ISD to distribute the credit?

Ans. The conditions to be fulfilled by ISD to distribute credit are:

- (a) Credit distributed to recipient under prescribed documents, which is issued to each of the recipient of credit.
- (b) Credit distributed should not exceed the credit available for distribution.
- (c) Tax paid on input services used by a particular location (registered as supplier), to be distributed only to that location.
- (d) Credit of tax paid on input service used by more than one location who are operational is to be distributed to all of them based on the pro rata basis of turnover of each locations in a State to aggregate turnover of all such locations who have used such services.

Q4. What are the documents through which the credit can be distributed by ISD?

Ans. An ISD can distribute credit to its recipient units by way of an ISD invoice prescribed in Rule 54 of the CGST Rules, 2017

Q5. How to distribute common credit among all the units of a ISD?

Ans. The common credit used by all the units can be distributed by ISD on pro rata basis i.e. based on the turnover of each unit to the aggregate turnover of all the units to which credit is distributed.

20.6 MCQs

Q1. The ISD may distribute the CGST and IGST credit to recipient outside the State as_____

- (a) IGST
- (b) CGST
- (c) SGST

Ans. (a) IGST

Q2. The ISD may distribute the CGST credit within the State as _____

- (a) IGST
- (b) CGST
- (c) SGST
- (d) Any of the above.

Ans. (b) CGST

Q3. According to the condition laid down for distribution of credit, ISD can distribute _____

- (a) Credit in excess of credit available
- (b) Only certain percentage of total credit available
- (c) Credit equal to the total credit available for distribution.
- (d) All of the above.

Ans. (c) Credit equal to the total credit available for distribution.

Q4. The credit of tax paid on input service used by more than one supplier is _____

- (a) Distributed among the suppliers who used such input service on pro rata basis of turnover in such State.
- (b) Distributed equally among all the suppliers
- (c) Distributed only to one supplier.
- (d) Cannot be distributed.

Ans. (a) Distributed among the suppliers who used such input service on pro rata basis of turnover in such State.

Statutory provisions

21. Manner of recovery of credit distributed in excess

Where the Input Service Distributor distributes the credit in contravention of the provisions contained in section 20 resulting in excess distribution of credit to one or more recipients of credit, the excess credit so distributed shall be recovered from such recipient(s) along with interest, and the provisions of section 73 or 74, as the case may be, shall mutatis mutandis apply for determination of amount to be recovered

Related Provisions of the Statute

Section or Rule	Description
Section 2(61)	Definition of 'Input Service Distributor'
Section 20	Manner of distribution of credit by Input Service Distributor
Section 73	Determination of tax not paid or short paid or erroneously

	refunded or input tax credit wrongly availed or utilised for any reason other than fraud or any wilful misstatement or suppression of facts.
Section 74	Determination of tax not paid or short paid or erroneously refunded or input tax credit wrongly availed or utilised by reason of fraud or any wilful misstatement or suppression of facts
Rule 65	Form and manner of submission of return by an Input Service Distributor

Relevant circulars, notifications, clarifications issued by Government:

1. Chapter Nineteen of the compilation of the GST Flyers as issued by the CBIC on 'Input Tax Credit Mechanism in GST'
2. Chapter Ten of the compilation of the GST Flyers as issued by the CBIC on 'Input Service Distributor in GST'

21.1 Introduction

The CGST Act clearly lays down that credit distribution is not 'to self', that is, a registered taxable person cannot distribute credit to himself. Each registered person being a distinct person u/s 25, must distribute to another registered taxable person but having the same PAN to whom the credit is most accurately attributable. And the consequence of incorrect distribution, due to inadvertence or misapplication of the provisions, are discussed here.

21.2 Analysis

(i) Excess Credit distributed in contravention of provision:

Excess credit distributed to one or more recipient of credit in contravention of ISD provision under Section 20 is recoverable from the recipient of such credit along with Interest. The recovery would be under the provisions of Section 73 or 74.

Example-1 Total Credit Available to ISD is 15,00,000/- & the credit distributed to all the units is ₹ 16,50,000/- (i.e. Delhi 10,00,000, unit Jaipur ₹ 4,00,000 & unit Gujarat ₹ 2,50,000). What will be the consequences?

Solution: The excess credit of 1,50,000 (₹ 16,50,000- ₹ 15,00,000) distributed would be recovered from the recipient along with interest and the provisions of section 73 or 74 shall apply mutatis mutandis for effecting such recovery.

Example-2 Total Credit Available to ISD is ₹ 15,00,000/- & the credit should have been distributed equal to all the units as all units had equal turnover, however credit distributed in violation of Section 21, as under:

Delhi ₹ 7,00,000, Jaipur ₹ 6,00,000, Gujarat ₹ 2,00,000.

What will be the consequences?

Solution: The excess credit of ₹ 2,00,000 (₹ 7,00,000- ₹ 5,00,000) shall be recovered from Delhi and ₹ 1,00,000 (₹ 600,000 – ₹ 5,00,000) shall be recovered from Jaipur along with interest and the provisions of section 73 or 74 shall apply mutatis mutandis for effecting such recovery.

The analysis of above provision in a pictorial form is summarised as follows:

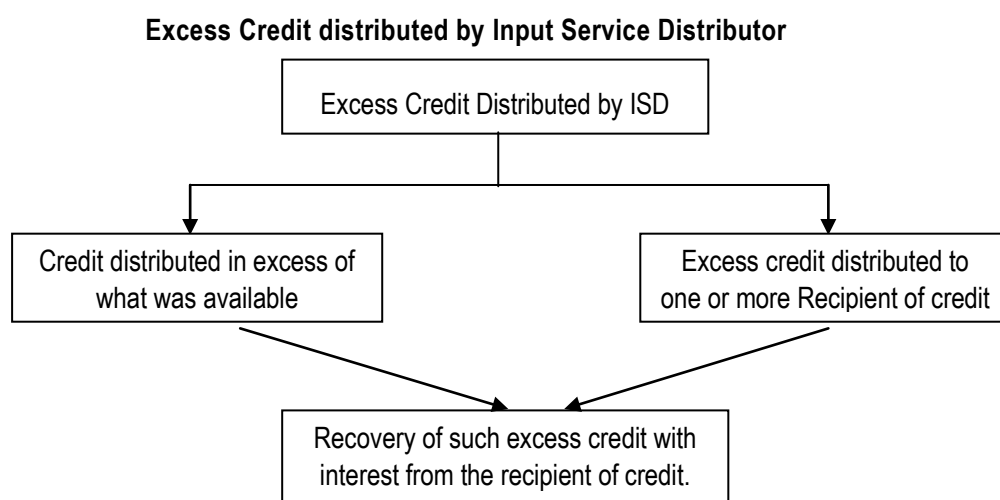

21.3 Comparative review

Earlier recovery provision was specified in Rule 14 of CENVAT Credit Rules. The CENVAT credit taken or utilized wrongly or has been erroneously refunded, was recovered along with interest under the provisions of sections 11A and 11AB of the Excise Act or sections 73 and 75 of the Finance Act.

Earlier, there was no specific provision for excess distribution of credit by ISD. Now specific provision is provided in the GST law providing for recovery of amount along with interest. Further, the relevant period for recovery of excess amount distributed is also provided in GST law.

21.4 FAQs

Q1. Whether the excess credit distributed could be recovered by the department?

Ans. Yes. Excess credit distributed could be recovered along with interest from recipient by the department.

Q2. What are the consequences of credit distributed in contravention of the provision of the Act?

Ans. The credit distributed in contravention of the provision of the Act is to be recovered from the unit to which it is distributed along with interest.