

FAQ and MCQ on Revised Model GST Law



The Institute of Chartered Accountants of India
(Set up by an Act of Parliament)
New Delhi

© The Institute of Chartered Accountants of India

All rights reserved. No part of this publication may be reproduced, stored in a retrieval system, or transmitted, in any form, or by any means, electronic, mechanical, photocopying, recording, or otherwise without prior permission, in writing, from the publisher.

DISCLAIMER:

The views expressed in this book are of the author(s). The Institute of Chartered Accountants of India may not necessarily subscribe to the views expressed by the author(s).

The information cited in this book has been drawn from various sources. While every effort has been made to keep the information cited in this book error free, the Institute or any office of the same does not take the responsibility for any typographical or clerical error which may have crept in while compiling the information provided in this book.

First Edition : February, 2017

Committee/Department : Indirect Taxes Committee

E-mail : idtc@icai.in

Website : www.icai.org; www.idtc.icai.org

Price : ₹ 200/-

ISBN : 978-81-8441-

Published by : The Publication Department on behalf of the Institute of Chartered Accountants of India, ICAI Bhawan, Post Box No. 7100, Indraprastha Marg, New Delhi - 110 002.

Printed by : Sahitya Bhawan Publications, Hospital Road, Agra - 282 003.

Foreword

The robust development in GST like passing of the 101st Constitutional Amendment (GST) Act, Creation of GST Council and its Secretariat, regular nine meetings of GST Council to discuss various issues relating to GST including broad contours of the GST rate structure, threshold exemption and parameters for composition scheme, details for compensation to States on implementation of GST, examination of draft model GST law, draft IGST law and the Compensation Law and administrative mechanism for GST, all reveals that the much-awaited GST implementation is just a step ahead for spurring growth, competitiveness, indirect tax simplification and greater transparency.

Appreciating the increasing changes and complexities taking place in the field of GST and its expected implementation from July 2017, the Indirect Taxes Committee of ICAI has come with the publication named “*FAQ and MCQ on Revised Model GST Law*”. This novel initiative of the Committee provides a comprehensive coverage of GST in question answer format as an easy & lucid way to understand the law. This would be further updated on passing of the Act and Rules in the near future.

We heartily appreciate CA. Madhukar N. Hiregange, Chairman, CA. Sushil Kumar Goyal, Vice-Chairman and other members of the Indirect Taxes Committee for developing this publication. We are sure that this publication would prove to be very useful in understanding the upcoming law and gaining a zeal for exploring the subject further.

We welcome the members to a fruitful and enriching experience.

CA. M. Devaraja Reddy

President, ICAI

CA. Nilesh Shivji Vikamsey

Vice-President, ICAI

Date: 6.2.2017

Place: New Delhi

Preface

The budget estimated revenue of Indirect Taxes of ₹ 9,31,579 crores out of total tax revenue estimated of the Central Government of ₹19,11,579 crores in the year 2017-18 exhibits that indirect taxation is a pivotal source of revenue of Centre. The States are also collecting more than 4 lakhs crores as VAT which is their main source of revenue. The Goods of and Services Tax (GST), a major taxation reform to be levied on supply of goods and/or services is likely to be passed in this Budget Session of the Parliament after release of Revised Model GST Law by Government on November 26th 2016. Therefore, the need of hour is to embrace the knowledge of professionals like Chartered Accountants.

Taking these facts into account, the Indirect Taxes Committee of ICAI has developed “FAQ and MCQ on Revised Model GST Law” with an aim to simplify the understanding of Revised Model GST. Section wise question and answer will enable reader to comprehend the Law vigorously and precisely.

We would like to express our sincere gratitude and thank to CA M. Devaraja Reddy, President, ICAI and CA. Nilesh Vikamsey, Vice-President, ICAI, for their guidance and encouragement to the initiatives of the Committee. Further, we must also thank Study Group on Indirect Taxes at Andhra Pradesh, Bangalore, Ernakulam, Chennai, Mumbai, Bhubaneswar, Guwahati, Kolkata, Pune, Ahmedabad, Delhi, Surat, Indore, Kanpur, Jaipur, Patna, Telangana and our Secretariat for their contribution in this publication and CA. Kapil Vaish and CA. Bimal Jain for reviewing the same.

We encourage reader to make full use of this learning opportunity. Interested members may visit website of the Committee www.idtc.icai.org and join the IDT update facility. We request to share your feedback at idtc@icai.in to enable us to make this publication more value additive and useful.

We welcome the Members to a fruitful and enriching learning experience.

CA. Madhukar Narayan Hiregange

Chairman
Indirect Taxes Committee

CA. Sushil Kumar Goyal

Vice-Chairman
Indirect Taxes Committee

Date: 6.02.2017

Place: New Delhi

CONTENTS

Chapter No.	Chapter Name	Page No.
CGST/SGST Law		
I	Preliminary	1
II	Levy of, and Exemption from, Tax	3
III	Time and Value of Supply	12
IV	Input Tax Credit	29
V	Registration	37
VI	Tax Invoice, Credit and Debit Notes	53
VII	Returns	68
VIII	Payment of Tax	92
IX	Transfer of Input Tax Credit	108
X	Refunds	109
XI	Accounts and Records	119
XII	Job Work	124
XIII	Electronic Commerce	135
XIV	Assessment	142
XV	Audit	152
XVI	Demands and Recovery	155
XVII	Inspection, Search, Seizure and Arrest	173
XVIII	Offences and Penalties	181

XIX	Prosecution and Compounding of Offences	195
XX	Appeals and Revision	204
XXI	Advance Ruling	223
XXII	Presumption as to Documents	230
XXIII	Liability to Pay in Certain Cases	232
XXV	Transitional Provisions	242
IGST Law		
I	Principles for Determining Supply of Goods and/or Services in the course of Inter-State Trade or Commerce	285
II	Levy and Collection of Tax	289
III	Place of Supply of Goods and/or Services	292
IV	Input Tax Credit	308
V	Apportionment of Tax and Settlement of Funds	310
VI	Zero Rated Supply	312
VII	Transitional Provisions	314

Chapter I

Preliminary

FAQ

Meaning and Scope of Supply (Section 3)

Q1. What are different types of supplies covered under the Supply definition?

Ans. Supplies include all forms of supply of goods and/or services such as sale, transfer, barter, exchange, license, rental, lease or disposal made or agreed to be made for a consideration by a person in the course or furtherance of business. It also includes Importation of services, for a consideration whether or not in the course or furtherance of business

Supplies made without consideration - Schedule I

Determining what is to be treated as goods / services - Schedule II

Activities or Transactions neither Supply of goods nor Supply of services - Schedule III & IV

Q 2. What are different forms of supply of goods?

Ans. Indicative list of supply of goods viz., sale, transfer, barter, exchange, license, rental, lease or disposal made or agreed to be made for a consideration by a person in the course or furtherance of business.

Q 3. What is Composite Supply and taxability of such supply?

Ans. Supplies involving two or more goods or services or any combination thereof, naturally bundled for supply in the ordinary course of business, wherein one of the components having essential character is known as principle supply. This composite supply shall be taxable at the rate applicable to principle supply.

For Example: In a natural bundle of supply of goods and insurance service on transportation, supply of goods is the essential supply and the rate applicable to such goods would be applicable for this composite supply.

Q 4. What is Mixed Supply and taxability of such supply?

Ans. A supply involving two or more supplies of goods or services or any combination thereof made for a single price and which is not a composite supply, is defined to be a mixed supply (i.e. not naturally bundled or there is no one principle supply in the mix of supplies). Whole supply would be taxable at the highest rate applicable for the components of such mixed supply.

For Example: A supply of a package consisting of canned foods, sweets, chocolates,

cakes, dry fruits, aerated drink and fruit juices when supplied for a single price is a mixed supply. Each of these items can be supplied separately and is not dependent on any other. It shall not be a mixed supply if these items are supplied separately. Highest rate of GST for the commodities in the mixed supply would be applied for the entire supply.

Q 5. Does Import of services get covered under the definition 'supply'?

Ans. Yes, Imports of services get covered under Section 3(1) (b) of the Revised Model GST Law read with Para 4 of Schedule I.

MCQ

Meaning and Scope of Supply (Section 3)

Q 1. What does Supply include?

- (a) Goods
- (b) Services
- (c) Goods or Services
- (d) Goods and Services
- (e) Goods and / or Services

Ans. (e) *Goods and / or services*

Q 2. What are different types of supplies covered under the Supply definition?

- (a) Supplies made with consideration
- (b) Supply made without consideration
- (c) Supplies covered under schedules
- (d) All of the above

Ans. (d) *All of the above.*

Q 3. What are different forms of supply of goods?

- (a) Sale
- (b) Transfer
- (c) Barter
- (d) Specified in Section 3 of the CGST Act.

Ans. (d) *Specified in Section 3 of the CGST Act.*

Chapter II

Levy of, and exemption from, tax

FAQ

Levy and Collection of Central/State Goods and Services Tax (Section 8)

- Q 1. What are the taxes that could get levied on an intra-state transaction?
Ans. CGST and SGST will be levied on an intra-state transaction as per Section 8 of CGST/SGST Act read with Section 4 of the IGST Act, 2016.
- Q 2. On what value CGST/SGST be levied?
Ans. CGST / SGST shall be levied on the value of the transaction as determined under Section 15 of the CGST / SGST Act.
- Q 3. Is there any maximum rate prescribed under CGST/SGST?
Ans. Yes, rate shall be notified by Central/State Government not exceeding 14%. So the maximum GST rate for any Goods/Service that could be prescribed together is $14+14 = 28\%$.
- Q 4. Who shall decide the rate to be notified?
Ans. Central/State government shall decide the rates of CGST/SGST on recommendation of the GST Council.
- Q 5. Who is responsible to pay the GST?
Ans. Generally, the supplier of goods / services is liable to pay GST. However, in certain cases, to be prescribed by Central/State Government, the responsibility will be on the recipient of supply. This is popularly known as reverse charge mechanism.
- Q 6. Is reverse charge mechanism applicable only to services?
Ans. No, Reverse charge applies to supplies of both goods and services.
- Q 7. Will CGST/SGST be levied on Imports?
Ans. Imports will not be liable to CGST/SGST as imports are covered under 'inter-State' transaction.

Composition Scheme (Section 9)

Q 8. Who shall be granted permission to opt for Composition levy?

Ans. Section 9 (1) specifies persons who are eligible to opt for Composition Levy.

Q 9. What is the threshold limit for opting to pay tax under composition scheme?

Ans. A supplier whose aggregate turnover in the preceding financial year did not exceed ₹ 50 lakhs.

Q 10. What is the rate applicable under composition levy?

Ans. Supplier opting for Composition levy shall pay a tax calculated on turnover at the rate as may be prescribed, but shall not less than 2.5% in case of manufacturer and 1% in case of other suppliers.

It may be noted that 2.5% and 1% would be in CGST as well as SGST Law each hence, effective rate would be 5% and 2% respectively. Further, composition scheme is not available on Services and inter-state outward supplies.

Q 11. Can taxable persons be eligible to opt for composition scheme only for one out of 3 business verticals?

Ans. No, composition scheme would be applicable for all business verticals/ registrations, which are separately held by the person with same PAN.

Q 12. Can Composition scheme be availed if taxable person effects inter-State outward supplies of goods?

Ans. No, a taxable person making interstate outward supplies of goods is ineligible for composition scheme.

Q 13. Can the taxable person under Composition Scheme claim input tax credit?

Ans. No, taxable person under composition scheme is ineligible to claim input tax credit

Q 14. Can a person receiving supplies from a taxable person who is under composition scheme, claim composition tax as input credit?

Ans. No, a person opting for composition scheme shall not collect any tax from the recipient of supplies. Hence, recipient of supplies is ineligible to claim any credit on supplies received from a taxable person who is under composition scheme.

Q 15. Can tax under Composition levy be collected from Customers?

Ans. No, suppliers opting for Composition levy cannot collect tax on supplies

Q 16. How to compute 'aggregate turnover' to determine eligibility for composition scheme?

Ans. As per section 2 (6) of the Model CGST/SGST Law, aggregate turnover includes the aggregate value of all taxable supplies, exempt supplies, export of goods and/ or services and inter-State supplies of a person having same PAN, to be computed on all India basis and excludes taxes, if any charged under CGST/SGST and IGST Act as the case may be.

Aggregate turnover does not include value of inward supplies on which tax is payable on reverse charge basis and the value of inward supplies.

Q 17. What does a person having the same PAN mean?

Ans. Person having same PAN means all the entities across India having the same PAN.

Q 18. What happens when the turnover during the year 2017-18 cross ₹ 50 lakhs after registration was granted as a composition dealer?

Ans. As per Sec 9 (2), the registration of a dealer whose turnover crosses ₹ 50 lakhs under Composition shall stand withdrawn from the day he crosses the limit.

Q 19. Can a person making supplies through electronic commerce operator get registered under composition scheme?

Ans. No, a person who makes supplies through electronic commerce operator and required to collect tax under Section 56 is not eligible to get registration under composition scheme.

Q 20. What are the penal consequences if a taxable person violates the condition and is not eligible for payment of tax under the composition scheme?

Ans. If the proper officer has reasons to believe that a taxable person was not eligible to pay tax under composition scheme, shall in addition to tax payable under the Act can demand penalty as well. Provisions of Sec 66 or 67 (as the case may be) would apply for determination of tax and penalty.

Taxable Person (Section 10)

Q 21. Who is taxable person?

Ans. Taxable person means a person who is registered or who is liable to be registered under Schedule V of the Revised Model GST Law

Q 22. Can all registered establishments covered under one PAN be called one taxable person?

Ans. No. Each establishment registered or required to be registered would be considered as a separate taxable person, though covered under a common PAN. Each of such

establishment would be considered as separate persons for the purpose of Revised Model GST Law.

Q 23. Any limit for compulsory registration?

Ans. Person is required to be registered if the aggregate turnover exceeds ₹.20 lacs in a financial year. In case of person located in specified North - Eastern States and Hill States, said limit stands reduced to ₹.10 lacs.

Q 24. Should a person dealing exclusively in supply of exempted/not taxable goods/services required to obtain registration?

Ans. No, such person need not obtain a registration.

Q 25. Who are the persons liable to be registered irrespective of their turnover limits?

- Ans.
1. Persons making any inter-State taxable supply
 2. Casual taxable persons
 3. Persons who are required to pay tax under reverse charge
 4. Non-resident taxable persons
 5. Persons who are required to deduct tax
 6. Persons who are required to collect tax under Section 56
 7. Person supplying on behalf of other person whether as agent or otherwise
 8. Input service distributor
 9. Person supplying goods through electronic commerce operator.
 10. Person supplying online information and database access or retrieval services from a place outside India to a person in India, other than a registered taxable person.
 11. Such other person or class of persons as may be notified by the Central Government or a State Government on the recommendation of the Council

MCQ

Levy and Collection of Central/State Goods and Services Tax (Section 8)

Q 1. What are the taxes that could get levied on an intrastate transaction?

- (a) CGST
- (b) SGST

- (c) Both the above
- (d) IGST

Ans. (c) Both the above

Q 2. Is there any maximum rate prescribed under IGST?

- (a) 14%
- (b) 28%
- (c) 26%
- (d) 30%

Ans. (b) 28%.

Q 3. Who is responsible to pay the GST?

- (a) Person supplying
- (b) Person receiving
- (c) Both the above could be liable
- (d) None

Ans. (c) Both the above could be liable. Generally, the person supplying is liable to pay GST, except in certain cases, to be prescribed by Central/State government, the responsibility is transferred on the recipient of supply, popularly known as reverse charge mechanism.

Q 4. What are the supplies for which reverse charge mechanism could apply?

- (a) Inward Supply of Goods/Services
- (b) Outward Supply of Goods/Services
- (c) Both the above
- (d) None of the above

Ans. (a) Inward Supply of Goods/Services

Q 5. What are the taxes levied on Imports?

- (a) CGST
- (b) SGST
- (c) IGST
- (d) Customs duty and IGST under Section 3 of Customs Tariff Act, 1975

Ans. (d) Customs duty and IGST under Section 3 of Customs Tariff Act, 1975

Composition Scheme (Section 9)

Q 6. Who among the following can opt for composition?

- (a) Person engaged in the supply of services
- (b) Person making any supply of goods which are not leviable to tax under this Act;
- (c) Person making any inter-State outward supplies of goods;
- (d) Who makes any supply of goods through an electronic commerce operator
- (e) None of the above

Ans. (e) *None of the above*

Q 7. What is the threshold limit of turnover in previous year for opting to pay tax under composition scheme?

- (a) ₹ 20 lacs
- (b) ₹ 10 lacs
- (c) Not exceeding ₹ 50 lacs
- (d) None of the above

Ans. (c) *Not exceeding ₹ 50 lacs*

Q 8. What is the rate applicable for a composition dealer, being manufacturer?

- (a) Not exceeding 2.5%
- (b) 5%
- (c) 0%
- (d) No composition for manufacturer

Ans. (a) *Not exceeding 2.5% (For CGST as well as SGST each)*

Q 9. What is the rate applicable for a composition dealer, being a person other than manufacturer?

- (a) Not exceeding 1%
- (b) 2%
- (c) 0%
- (d) None of the above

Ans. (a) *Not exceeding 1% (For CGST as well as SGST each)*

Q 10. Can composition tax be less than 1%?

- (a) Yes

- (b) No
- (c) Can't Say
- (d) Central/State Government to decide

Ans. (b) No

Q 11. Can taxable persons be eligible to opt for composition scheme only for one out of 3 business verticals?

- (a) Yes
- (b) No
- (c) Can't Say
- (d) Central/State Government to decide

Ans. (b) No

Q 12. Can Composition scheme be availed if taxable person effects interstate supplies?

- (a) Yes
- (b) No
- (c) Can't Say
- (d) Central/State Government to decide

Ans. (b) No

Q 13. Can the taxable person under Composition Scheme claim input tax credit?

- (a) Yes
- (b) No
- (c) Can't Say
- (d) Central/State Government to decide

Ans. (b) No

Q 14. Can the customer who buys from a taxable person who is under composition scheme claim composition tax as input credit?

- (a) Yes
- (b) No
- (c) Can't Say
- (d) Central/State Government to decide

Ans. (b) No

Q 15. Can Composition tax be collected from Customers?

- (a) Yes
- (b) No
- (c) Can't Say
- (d) Central/State Government to decide

Ans. (b) No

Q 16. Which of the following are considered for calculating aggregate turnover?

- (a) Taxable supplies
- (b) Exempt Supplies
- (c) Both of the above
- (d) Non-taxable supplies

Ans. (c) Both the above.

Q 17. What happens when the turnover during the year 2017-18 cross ₹ 50 lakhs after registration was granted as a composition dealer?

- (a) He can continue under composition for that year
- (b) He will have to pay tax for whole of the turnover in that year
- (c) He will not be eligible for composition on turnover after crossing ₹ 50 lacs
- (d) None of the above

Ans. (c) He will not be eligible for composition on turnover after crossing ₹ 50 lacs

Q 18. Can a person making supplies through electronic commerce operator get registered under composition scheme?

- (a) Yes
- (b) No
- (c) Can't say
- (d) Government to decide

Ans. (b) No

Taxable Person (Section 10)

Q 19. Every supplier shall be liable to be registered under Revised Model GST Law in the State from where he makes a taxable supply of goods and/or services if his aggregate turnover in a financial year.....:

- (a) ₹ 10 lacs
- (b) Exceeds ₹ 20 lacs
- (c) ₹ 50 lacs
- (d) No limit for registration

Ans. (b) Exceeds ₹ 20 lacs

Q 20. Which of the following persons are not required to be compulsorily registered, irrespective of the threshold limits provided under Revised Model GST Law?

- (a) Casual Dealer
- (b) Person making sale of taxable goods
- (c) Persons who are required to pay tax under reverse charge
- (d) Non-resident taxable persons,

Ans. (b) Person making sale of taxable goods

Q 21. Should a person dealing exclusively in supply of exempted/not taxable goods/services is required to obtain registration?

- (a) Yes
- (b) No
- (c) Can't say
- (d) Government to decide

Ans. (b) No.

Chapter III

Time and Value of Supply

FAQ

Time of supply of goods (Section 12)

Q 1. How are the provisions relating to 'time of supply' relevant under Revised Model GST Law?

Ans. The provisions relating to time of supply of goods / services are relevant in ascertaining the time to remit the taxes on a particular transaction involving supply of goods / services under Revised Model GST Law. This Law provides separate provisions for time of supply of goods and services viz., Section 12 for time of supply of goods and Section 13 for time of supply of services.

Q 2. What will be the time of supply of goods, generally?

Ans. Generally, in terms of Section 12, the time of supply of goods shall be the earliest of the following:

- (a) Date of issue of invoice; or
- (b) Due date of issue of invoice under section 28; or
- (c) Date on which supplier receives the payment

Q 3. What will be the date on which supplier receives the payment to ascertain the time of supply of goods?

Ans. In terms of the Explanation 2 appended to Section 12(2), the date on which supplier receives the payment shall be the earliest of the following dates:

- (a) Date on which payment is entered in books of accounts of the supplier; or
- (b) Date on which payment is credited to the bank account.

Q 4. What will be the time of supply where multiple invoices are issued for a single consignment involving supply of goods?

Ans. The time of supply of goods shall be the date of issuance of invoice; or due date for issuance of invoice or receipt of payment by the supplier. In the event, the supplier has not received the payment in case of multiple invoices issued for a single consignment of supply, the time of supply shall be ascertained with reference to the date of issuance of such invoices since the provisions relating to time of supply of goods does not prescribe date of receipt of goods by the recipient as one of the factors to ascertain the time of supply of goods.

Q 5. What will be the time of supply where tax is liable to be paid under reverse charge mechanism?

Ans. In case of tax liable to be paid under reverse charge mechanism, the time of supply shall be the earliest of the following:

- (a) Date of receipt of goods by the recipient; or
- (b) Date on which the payment is entered in the books of accounts of the recipient; or
- (c) Date on which payment is debited in the bank account of the recipient; or
- (d) Date immediately following thirty days from the date of issue of invoice by the supplier.

Where the time of supply cannot be ascertained as above, the date when the date of entry in the books of accounts of the recipient shall be the time of supply of goods.

Q 6. What will be the time of supply in case of supply of vouchers?

Ans. In terms of Section 12(4), time of supply of vouchers shall be the earliest of the following:

- (a) date of issue of voucher, if the supply is identifiable at that point; or
- (b) date of redemption of voucher, in all other cases.

Eg: Mr. A buys vouchers from Amazon India of worth ₹ 1,000/- dated December 01, 2016. Mr. A gifts such vouchers to Mr. B who redeems such vouchers for purchase of goods from Amazon India on January 31, 2017. – Time of supply is the date of issue of vouchers viz., December 01, 2016.

Q 7. What is time of supply of goods with respect to escalation in price after the issuance of invoice Eg: Invoice is issued for ₹ 5,000 on June 22, 2016 by the supplier. Subsequently, due to variation in price the recipient pays scenario 1: ₹ 5,500/- and scenario 2: ₹ 8,000/-. Further, the Date on which payment is entered in books of accounts of the supplier is June 30, 2016 and Date on which payment is credited to the bank account is June 28, 2016 . Date of issue of invoice pertaining to ₹ 500/ and ₹ 3000/- is July 3,2016. Due date of issue of invoice under section 28 is July 1 ,2016

Ans. In terms of the proviso to Section 12(b) of the Revised Model GST Law, the time of supply with respect to the amount received in excess upto ₹ 1,000/- of the amount indicated in tax invoice, the time of supply shall be the date of issue of invoice. Where the amount received exceeds ₹ 1,000/-, the time of supply of goods shall be the earliest of the following (in case where the invoice is already issued):

- (a) Date of issue of invoice; or
- (b) Due date of issue of invoice under section 28; or

(c) Date on which supplier receives the payment, which in terms of the Explanation 2 appended to Section 12(2), shall be the earliest of the following dates:

- Date on which payment is entered in books of accounts of the supplier; or
- Date on which payment is credited to the bank account.

Accordingly, the time of supply in each of the scenarios given in the example would be as follows:

Scenario 1: The time of supply of goods with respect to the amount of ₹. 500/- received in excess shall be the date of invoice June 22, 2016.

Scenario 2: The time of supply with respect to the amount of ₹ 3,000/- (₹ 8000 - ₹ 5000) would be as follows:

Date of issue of invoice	July 3,2016
Due date of issue of invoice under section 28	July 1 ,2016
Date on which payment is entered in books of accounts of the supplier	June 30, 2016
Date on which payment is credited to the bank account	June 28, 2016
Time of Supply of Goods	June 28,2016

Q 8. What would be the date of payment for ascertaining time of supply of goods?

Ans. The date of payment as referred in provisions relating to time of supply of goods and shall be the earliest of the following:

- (a) date when the payment entry in relation to supply of goods is recorded in books of accounts; or
- (b) date on which the payment is credited to suppliers bank account.

Q 9. What would be the 'due date of issuance of invoice' with reference to the provisions relating to time of supply of goods?

Ans. Section 28(1) of the Model CGST/SGST Law prescribes the time at which the tax invoice should be issued. Accordingly, the due date for issuance of invoice would be as follows:

- (a) Supply involves movement of goods – It is provided that the tax invoice should be issued before or at the time of removal of goods for supply to the recipient. As such, it is inferred that the date of removal of goods shall be the 'due date of issuance of invoice';
- (b) Any other case – delivery of goods or making available thereof. As such, it is inferred that the date on which goods are delivered to the recipient or the date on which goods are made available to the recipient is the 'due date of issuance of invoice'.

Proviso to Section 28(1) of the Model CGST/SGST Law also empowers the Central / State Government to prescribe by notification, categories of goods and/or supplies in respect of which the tax invoice shall be issued within the time prescribed. In such a scenario, the last date within which the invoice should be issued will be the 'due date of issuance of invoice'.

Q 10. What would be the time of supply where composite supply involves supply of goods as principal supply?

Ans. The general provisions relating to time of supply of goods are applicable where composite supply involves goods as principal supply. Accordingly, the time of supply of such composite supply shall be the earliest of the following:

- (a) Date of issue of invoice; or
- (b) Due date of issue of invoice under Section 28; or
- (c) Date on which supplier receives the payment.

Q 11. Time of supply in case of continuous supply of goods?

Ans. In terms of Section 2(30) of the Revised Model GST Law, 'continuous supply of goods' is defined to mean a supply of goods which is provided, or agreed to be provided, continuously or on recurrent basis, under a contract, whether or not by means of a wire, cable, pipeline or other conduit, and for which the supplier invoices the recipient on a regular or periodic basis.

The Revised Model GST Law, does not provide any specific provisions for ascertaining the time of supply in case of 'continuous supply of goods'. Accordingly, the time of continuous supply of goods, in terms of Section 12 shall be the earliest of the following:

- (a) Date of issue of invoice; or
- (b) Due date of issue of invoice; or
- (c) Date on which supplier receives the payment.

Q 12. Time of supply in case of supply of goods by e-commerce entities?

Ans. The Revised Model GST Law, does not provide separate provisions for ascertaining the time of supply of goods by e-commerce entities. Accordingly, in terms of Section 12 shall be the earliest of the following:

- (a) Date of issue of invoice; or
- (b) Due date of issue of invoice; or
- (c) Date on which supplier receives the payment

Time of supply of services (Section 13)

Q 13. How to ascertain the time of supply of services?

Ans. In terms of Section 13, the time of supply of services shall be the earliest of the following:

- (a) Date of issue of invoice; or
- (b) Due date of issue of invoice under Section 28; or
- (c) Date on which supplier receives the payment, which in terms of the Explanation 2 appended to Section 13(2), shall be the earliest of the following dates:
 - Date on which payment is entered in books of accounts of the supplier; or
 - Date on which payment is credited to the bank account

Illustration:

Date of invoice	December 31, 2016	Time of supply of services shall be December 10, 2016
Due date of issue of invoice under Section 28	December 15, 2016	
Advance payment received by way of cheque and the entry for receipt of payment is recorded books of accounts	December 10, 2016	
Amount credited to bank account of supplier	December 12, 2016	

Q 14. What is time of supply of service with respect to escalation in price after the issuance of invoice. Eg: Invoice is issued for ₹ 5,000 on June 22, 2016 by the supplier. Subsequently, due to variation in price the recipient pays scenario 1: ₹ 5,500/- and scenario ₹ 8,000/- .Further, the Date on which payment is entered in books of accounts of the supplier is June 30, 2016 and Date on which payment is credited to the bank account is June 28, 2016 . Date of issue of invoice pertaining to ₹ 500/ and ₹ 3000/- is July 3,2016. Date of Supply of Service July 1,2016. Due date of issue of invoice under section 28 is July 30, 2016

Ans. In terms of the proviso to Section 13(2)(b) of the Revised Model GST Law, the time of supply of service with respect to the amount received in excess upto ₹ 1,000/- of the amount indicated in tax invoice, the time of supply shall be the date of issue of invoice. Where the amount received exceeds ₹ 1,000/-, the time of supply of services shall be the earliest of the following (in case where the invoice is already issued):

- (a) Date of issue of invoice; or

- (b) Due date of issue of invoice under section 28; or
- (c) Date on which supplier receives the payment, which in terms of the Explanation 2 appended to Section 13(2), shall be the earliest of the following dates:
- Date on which payment is entered in books of accounts of the supplier or
 - Date on which payment is credited to the bank account

Accordingly, the time of supply in each of the scenarios given in the example would be as follows:

Scenario 1: The time of supply of service with respect to the amount of ₹. 500/- received in excess shall be the date of invoice June 22, 2016.

Scenario 2: The time of supply of service with respect to the amount of ₹ 3,000/- (₹ 8000 - ₹ 5000) would be as follows:

Date of issue of invoice	July 3, 2016
Due date of issue of invoice under section 28	July 30, 2016
Date on which payment is entered in books of accounts of the supplier	June 30, 2016
Date on which payment is credited to the bank account	June 28, 2016
Time of Supply of Service	June 28, 2016

Q 15 Whether the advances received prior to provision of service are liable to tax under Revised Model GST Law?

Ans. In terms of Section 13 of the Revised Model GST Law, the time of supply of services refers to the date on which payment is received by the supplier. Accordingly, the service provider should remit the applicable taxes on such advances in the month in which the money is received even where the services are not supplied / provided.

Q 16. What kind of supply of goods / services are liable to tax under reverse charge mechanism under Revised Model GST Law?

Ans. Section 2(87) of Revised Model GST Law defines 'reverse charge' to mean the liability to pay tax by the recipient of supply of goods or services instead of the supplier of such goods or services in respect of such categories of supplies as notified under sub-section (3) of Section 8.

Section 8(3) of the Revised Model GST Law, empowers the Central / State Government to specify categories of supply of goods and / or services which are liable to tax under the reverse charge mechanism and the tax thereon shall be paid by the recipient of such goods and / or services.

Accordingly, under the GST regime, tax is liable to be paid under reverse charge mechanism on such categories of goods and services, which will be notified.

Q 17. What would be the time of supply of services where the tax is required to be paid under reverse charge mechanism?

Ans. In terms of Section 13(3), the time of supply of services for remittance of tax under reverse charge mechanism shall be the earliest of the following:

- (a) Date of payment; or
- (b) Sixty days from the date of issuing invoice by the supplier

Further, where it is not possible to determine the time of supply under clause (a) or (b), the time of supply shall be the date of entry in the books of account of the recipient of supply

Q 18. Whether the date of completion of service would be relevant for determining time of supply?

Ans. Section 13 of the Revised Model GST Law, does not refer to the date of completion of provision of service. However, it refers to the due date of issuance of invoice. In terms of Section 28, a registered taxable person supplying taxable services shall, before or after the provision of service but within a period prescribed in this behalf, issue a tax invoice, showing the description, value, the tax payable thereon and such other particulars as may be prescribed.

Q 19. What would be the date of payment for ascertaining time of supply of services?

Ans. The date on which the supplier receives the payment as referred in Explanation 2 to Section 13(2) relating to time of supply of services shall be the earliest of the following:

- (a) date when the payment entry in relation to supply of services is recorded in books of accounts; or
- (b) date on which the payment is credited to suppliers bank account.

It is pertinent to mention that, in terms of Explanation to Section 13 (3) relating to time of supply of services in case of *reverse charge*, the date on which the payment is made shall be the earliest of the following:

- (a) the date on which the payment is entered in the books of accounts of the recipient or
- (b) the date on which the payment is debited in his bank account.

Q 20. Time of supply of services under reverse charge mechanism where the supplier of service is associated enterprises?

Ans. In case of associated enterprises located within India, the time of supply in terms of Section 13(3) shall be the earliest of the following:

- (a) Date of payment; or
 (b) Sixty days from the date of issuing invoice by the supplier; or

Where, it is not possible to determine the time of supply under clause (a) or (b), the time of supply shall be the date of entry in the books of account of the recipient of supply

Where associated enterprises is located outside India, the time of supply shall be the earliest of the following dates:

- (a) Date of entry in the books of accounts of the recipient; or
 (b) Date of payment.

Illustration :

Time of Supply of Services under Reverse Charge in case of Associated Enterprises and Associated Enterprises as:

Particulars	Non-associated enterprises	Associated Enterprises
Date on which payment is entered in books of accounts of recipient	28.09.2017	28.09.2017
Date on which payment is debited to bank account of recipient	30.09.2017	30.09.2017
Date of issuance of invoice by supplier	23.08.2017	23.08.2017
Sixty days from the date of issuing invoice	21.10.2017	21.10.2017
Date of entry in the books of accounts of the recipient	24.08.2017	24.08.2017
Time of supply	28.09.2017	24.08.2017

Q 21. What does associated enterprises referred to in Section 13(3) of the Revised Model GST Law mean?

Ans. In terms of Section 2(13), the 'associated enterprises' shall have the meaning assigned to it in Section 92A of the Income Tax Act, 1961.

Q 22. What would be the 'due date of issuance of invoice' with reference to the provisions relating to time of supply of services?

Ans. A registered taxable person supplying services, in terms of Section 28(2) shall issue the tax invoice before or after the provision of service but within a period prescribed in this behalf. Accordingly, the last date within which the invoice should be issued will be the 'due date of issuance of invoice'.

The proviso to Section 28(2) empowers the Central / State Government to specify the categories of service in respect of which any other document issued in relation to supply shall be deemed to be a tax invoice. In such a scenario the last date within which such other document should be issued will be the 'due date of issuance of invoice'.

Q 23. What would be the time of supply in case of works contract?

Ans. In terms of entry (f) to clause 5 of Schedule II, the works contract under the GST regime should be treated as supply of service. Accordingly, in terms of Section 13, the time of supply of services shall be the earliest of the following:

- (a) Date of issue of invoice; or
- (b) Due date of issue of invoice under Section 28; or
- (c) Date when the payment entry in relation to supply of services is recorded in books of accounts; or
- (d) Date on which the payment is credited to suppliers bank account.

Q 24. What would be the time of supply where composite supply involves supply of services as principal supply?

Ans. The general provisions relating to time of supply of services are applicable where composite supply involves services as principal supply. In terms of Section 13, the time of supply of services shall be the earliest of the following:

- (a) Date of issue of invoice; or
- (b) Due date of issue of invoice under Section 28; or
- (c) Date when the payment entry in relation to supply of services is recorded in books of accounts; or
- (d) Date on which the payment is credited to supplier's bank account.

Q 25. Time of supply in case of continuous supply of services?

Ans. 'Continuous supply of services' in terms of Section 2(31) of the Revised Model GST Law, means a supply of services which is provided, or agreed to be provided, continuously or on recurrent basis, under a contract, for a period exceeding three months with periodic payment obligations and includes supply of such service as the Central or a State Government may, whether or not subject to any condition, by notification, specify. Accordingly, in terms of Section 13, the time of supply of services shall be the earliest of the following:

- (a) date of issue of invoice; or

- (b) due date of issue of invoice under Section 28; or
- (c) date when the payment entry in relation to supply of services is recorded in books of accounts; or
- (d) date on which the payment is credited to suppliers bank account.

Q 26. Time of supply where services are supplied online?

Ans. The Revised Model GST Law, does not provide separate provisions for ascertaining the time of supply of service where such services are supplied online. Accordingly, in terms of Section 13, the time of supply of services shall be the earliest of the following:

- (a) Date of issue of invoice; or
- (b) Due date of issue of invoice under Section 28; or
- (c) Date when the payment entry in relation to supply of services is recorded in books of accounts; or
- (d) Date on which the payment is credited to suppliers bank account.

Q 27. Time of supply of services in case of import of services?

Ans. In terms of Section 3(1) of the Revised Model GST Law, supply includes import of services for a consideration whether or not in the course or furtherance of business. Accordingly, the recipient of services would be liable to pay tax on import of service.

The Revised Model GST Law does not provide separate provisions for ascertaining the time of supply in case of import of services. Accordingly, time of supply of services under RCM provisions would be applicable as provided under Sec 13(3) of the Revised Model GST Law.

Change in Rate of Tax in respect of supply of goods or services (Section 14)

Q 28. Does Section 14 of Revised Model GST Law apply to both goods and services?

Ans. Yes. Section 14 of Revised Model GST Law is common for supply of goods and supply of services and is applicable when there is change in the rate of tax.

Q 29. Does section 14 override section 12 and Section 13?

Ans. Yes. Section 12 and Section 13 are general provisions governing time of supply of goods and services. Section 14 is a specific provision, which is applicable when there is change in the rate of tax

Q 30. How do we determine the rate of tax in case there is change in the tax rates?

Ans. Three important events need to be considered – Date of raising invoice, receipt of payment and completion of supply. If any of the two events occur before the change in rate of tax then the old rate will apply else the new rate will apply.

Illustration – Rate of GST on Supply made on or after September 1, 2017 increased from say 18% to 20% then the tax to be applied on supplies will be as under

Before – Event occurred before September 1, 2017

After – Event occurred on or after September 1, 2017

Supply Provided	Invoice issued	Payment received	GST Rate
Before	After	After	20%
Before	Before	After	18%
Before	After	Before	18%
After	Before	After	20%
After	Before	Before	18%
After	After	Before	20%

Q 31. I have received the payment but I have not deposited the cheque in the bank account. What is the date of receipt of payment?

Ans. The date of receipt of payment is date of entry in the books or date of credit in the bank account whichever is earlier.

Further, the date of receipt of payment shall be the date of credit in the bank account when such credit in the bank account is after four working days from the date of change in the rate of tax.

Q 32. What is the rate of GST to be charged on advances received before the change in rate of tax if the supply is completed after the change is rate of tax?

Ans. If the invoices is also raised before the change in rate of tax then the old rate will apply even though the supply is complete after the change in rate of tax. Else, the new rate will apply.

Q 33. If 95% of the work is complete before the change in rate of tax but invoice can be raised only after completion of supply then what is the rate of tax to be applied?

Ans. Assuming the supply is completed after the change in rate of tax, new rate will apply.

Q 34. In case of Construction Contracts, builders remit taxes on receipt of payment or completion of slabs as provided in the contract. What will the impact due to change in the tax rates?

Ans. For payments received before the change in rate of tax, if invoices are also raised before the change in rate of tax, old rate will apply. Else the new rate will apply.

For slab completion before the change in rate of tax, if invoices are also raised before the change in rate of tax, old rate will apply. Else the new rate will apply.

Q 35. Will I be required to pay GST at the new GST rate on Debtors outstanding as on the date of change in the rate of tax?

Ans. If the supply was complete for such outstanding balances before the change in rate of tax then old rate will apply. Else the new rate will apply.

Q 36. I have raised the invoice with old rate of tax but now I am required to remit the taxes based on new rate of tax. Can I recover the additional tax payable by me from my customer?

Ans. Yes. You can raise a supplementary invoice / debit note to recover the additional tax from the customer.

Q 37. Will the customer be able to take credit of additional taxes referred at Q 36?

Ans. If the customer is entitled to claim the credit of original taxes then he will be entitled to avail the credit of the additional taxes as well subject to conditions for availment of credit.

Q 38. Will this provision apply even when the rate of tax decreases?

Ans. Yes. This provision is applicable under both circumstances – Increase in rate of tax and decrease in rate of tax.

Value of Taxable Supply (Section 15)

(Note – Valuation Rules referred was issued under Model GST Law and may be revised in near future)

Q 40. Does Section 15 apply to both goods and services?

Ans. Yes. Section 15 is common for supply of goods and supply of services.

Q 41. Are there separate valuation provisions for CGST, SGST and IGST?

Ans. No. Section 15 is common for all three taxes.

Q 42. Will the valuation rules provided in Section 15 apply to IGST payable on import of goods?

Ans. No. Customs Law will be applicable for valuation of imported goods.

Q 43. Will the Customs Valuation apply to IGST payable on import of services?

Ans. No. Customs Law will be applicable only for valuation of imported goods. Section 15 will apply for valuation of import of services

Q 44. Is reference to Valuation Rules required in all cases?

Ans. No. Reference to Valuation Rules is required only when the buyer and seller are not related or price is not the sole consideration for the transaction.

Q 45. What is to be done if there are certain factors affecting price though the transaction is not covered by section 15(4)?

Ans. Valuation Rules will be issued to value the supply in various scenarios.

Q 46. Can the value of supplies be a deemed value?

Ans. Section 15(5) empowers the Government to prescribe the value of certain supplies which may or may not be linked to the transaction value.

Q 47. When will the buyer and supplier be treated as related?

Ans. The relationship will be examined based on the provisions of Section 2(84) which defines the term "related persons".

Q 48. If the related parties transact at arm's length price, can the valuation still be questioned?

Ans. The valuation between related parties can be questioned. If the parties are able to prove that the relationship has not influenced the price then the transaction value will be treated as the value of supply on which tax will have to be discharged.

Q 49. What is the meaning of the term "Price is not the sole consideration"?

Ans. When the buyer indirectly compensates the seller for the supply of goods / services, price is not the sole consideration. Eg. Buyer discharges the loan of seller which was payable to a third party.

Q 50. Can any additions be made to Transaction Value?

Ans. Yes. Section 15 provides for five additions which can be made to the transaction value.

Q 51. Should the transaction value include the GST tax or exclude the GST tax?

Ans. Transaction Value exclude the taxes payable under GST. However, taxes, cesses etc. applicable under any other law will be included in the transaction value for computation of taxes under GST.

Q 52. Will the flight tickets booked by client for travel of Chartered Accountants to facilitate an outstation audit be liable to GST?

Ans. Expenses incurred by the recipient in relation to supplies made by supplier of goods / services is to be included in the transaction value. Hence, the value of flight booked will have to be included by Chartered Accountant on their invoice for computation of transaction value.

Q 53. Will discounts given to customers be allowed as deduction from transaction value?

Ans. Discounts can be classified into two:

- Discount at the time of Sale – Allowed as a deduction provided if the discount is recorded on the face of invoice.
- Post-Sale Discount – If such discount is based on the arrangement entered into before or at the time of supply and the same can be linked to the relevant invoice then the same is allowed as a discount provided the recipient reverses the tax credit related to such discount.

Q 54. Quantity discounts are not recorded on the face of the invoice. Can the Quantity discounts be claimed as deduction while computing GST?

Ans. Quantity Discounts are allowed based on the volume / value of purchases made by the customer for a particular period. The discount is allowed at the end of a particular period based on the pre agreed rates entered into between the supplier and the recipient. The supplier is in a position to link discount with each invoice and hence the same will be allowed as a deduction. However, the recipient needs to reverse credit to the extent of such discount.

Q 55. Can the transaction value be questioned if supplier and recipient's relationship come into existence after entering into a contract/arrangement to supply goods or services?

Ans. The laws assume that the relationship between the contracting parties prima facie has influenced the price at which the transaction is being carried out. Since the relationship did not exist on the date the prices were finalized (i.e. entering into the contract), the transaction value should be accepted.

Q 56. Will GST be applicable on any interest charged for payment after the credit period?

Ans. Interest, Penalty or Late fee charged from the customer would also be liable to GST.

Q 57. In certain cases, the selling price of the final product is less since subsidy is received from Government. Are subsidies received from Government required to be included in the transaction value?

Ans. Subsidies provided by Central / State Governments are not required to be included in the transaction value.

Q 58. Are subsidies received from Private Enterprises on procurement of Eco Friendly capital goods required to be included in the transaction value?

Ans. Subsidies directly linked to the price of the supply is required to be added. Since, the price of supply is not directly linked to the subsidy given on capital goods, the same is not required to be included.

Q 59. Will the Customs duty paid by Customs House Agent on behalf of the client also be required to be included in the transaction value?

Ans. Presently, the aforementioned expenses are treated as reimbursements as pure agent and hence not liable to service tax. Even, in terms of Rule 8 of the Valuation Rules provided under Model GST Law, the expenses borne on behalf of the client as pure agent will be excluded from the value of the taxable service.

Further, we will have to wait for the valuation rules to be issued under Revised Model GST to decide on treatment of such expenses.

MCQ

Change in Rate of Tax in respect of supply of goods or services (Section 14)

Q 1. There was increase in tax rate from 20% to 24% w.e.f. 1.6.2017. Which of the following rate is applicable when services provided after change in rate of tax in June 2017 but invoice issued and payment received in April 2017

- (a) 20%
- (b) 24%
- (c) 30%
- (d) None of above

Ans. (a) 20%

Q 2. There was increase in tax rate from 20% to 24% w.e.f. 1.6.2017. Which of the following rate is applicable when services provided and invoice raised after change in rate of tax in June 2017 but payment received in April 2017

- (a) 20%
- (b) 24%
- (c) 30%
- (d) None of above

Ans. (b) 24%

Q 3. There was increase in tax rate from 20% to 24% w.e.f. 1.6.2017. Which of the following rate is applicable when invoice was issued after change in rate of tax in June 2017 but payment received and services provided in April 2017

- (a) 20%
- (b) 24%

- (c) 30%
- (d) None of above

Ans. (a) 20%

Q 4. There was reduction in tax rate from 24% to 20% w.e.f. 1.6.2017. Which of the following rate is applicable when invoice was issued after change in rate of tax in June 2017 but payment received and services provided in April 2017

- (a) 20%
- (b) 24%
- (c) 30%
- (d) None of above

Ans. (a) 20%

Value of Taxable Supply (Section 15)

Q 5. The value of supply of goods and services shall be the

- (a) Transaction value
- (b) MRP
- (c) Market Value
- (d) None of above

Ans. (a) *Transaction value*

Q 6. The value of supply should *include*

- (a) Any taxes, duties, cesses, fees charged by supplier separately
- (b) Interest, late fee or penalty for delayed payment of any consideration for any supply
- (c) Subsidies directly linked to the price except subsidies provided by the Central and State Government
- (d) All of the above

Ans. (d) *All of the above*

Q 7. When can the transaction value be rejected for computation of value of supply?

- (a) When the buyer and seller are related and price is not the sole consideration
- (b) When the buyer and seller are related or price is not the sole consideration
- (c) It can never be rejected
- (d) When the goods are sold at very low margins

Ans. (b) *When the buyer and seller are related or price is not the sole consideration*

Q 8. What deductions are allowed from the transaction value?

- (a) Discounts offered to customers
- (b) Packing Charges
- (c) Amount paid by customer on behalf of the supplier
- (d) Freight charges incurred by the supplier for CIF terms of supply

Ans. (a) Discounts offered to customers

Q 9. If the goods are supplied to related parties then how should the taxable person ascertain the value of supplies?

- (a) Seek the help of the GST officer
- (b) Check the prices at which goods are sold to unrelated person
- (c) Identify the prices at which goods are sold by the unrelated person to his customer
- (d) Refer the Rules which will be prescribed for this purpose

Ans. (d) Refer the Rules which will be prescribed for this purpose

Chapter IV

Input Tax Credit

FAQ

Eligibility and conditions for taking input tax credit (Section 16)

Q 1. Whether capital goods are not inputs?

Ans. The definition of input as per section 2(52) means any goods other than capital goods used or intended to be used by a supplier in the course or furtherance of business. Therefore, the capital goods are not inputs. Capital goods is defined as per section 2(19) to mean goods the value of which is capitalized in the books of account of the person claiming the credit and which are used or intended to be used in the course or furtherance of business.

Q 2. What is the mode of credit? Is it on receipts of inputs, or on the basis of the documents or both?

Ans. Section 16(2) states that the taxable person shall be entitled to the credit of input tax, if all the following four conditions are satisfied:

- The receiver is in possession of tax invoice or debit note or any other tax paying documents
- The receiver has received the goods and or services
- The supplier has paid output taxes to the appropriate government
- The receiver has furnished the monthly return.

Q 3. Whether Input tax credit on Capital Goods is allowed in one installment?

Ans. Yes, under the Revised Model GST Law the input tax credit on capital goods is allowed in one installment except in respect of pipelines and telecommunication tower fixed to earth by foundation or structural support including foundation and structural support thereto.

Q 4. One of the conditions to claim credit is that the receiver is in possession of tax invoice or debit note or any other tax paying documents. What are the taxpaying documents?

Ans. The taxpaying documents can be bill of entry, supplementary invoice, running bill etc.

Q 5. What is the time limit within which the recipient of service is liable to pay the value of supply with taxes to the supplier of service to avail the input tax credit?

Ans. The time limit is three months from the date of issue of invoice by the supplier of service within which the recipient is liable to pay the value of supply along with taxes to the supplier of service to avail the input tax credit.

Q 6. In case the amount is paid partly to the supplier of service, whether full taxes can be adjusted first? If no, then whether it has to be calculated proportionately?

Ans. The time limit is three months from the date of issue of invoice by the supplier of service within which the recipient is liable to pay the value of supply along with taxes to avail the input tax credit. Where the amount is paid partly, then it can be calculated proportionately to avail the input tax credit.

Q 7. One of the conditions to claim credit is that the receiver has received the goods and or services. Is there any provision for deemed credit in case of transfer of document of title before or during the movement of goods?

Ans. Explanation to section 16(2) states that it is deemed that the taxable person has received the goods where the goods are delivered by a supplier to a recipient or any other person on the direction of taxable person whether acting as agent or otherwise, before or during movement of goods either by way of transfer of documents of title to goods or otherwise.

Q 8. Whether the taxable person can avail the benefits of input tax credit and depreciation on the tax component of capital goods?

Ans. Section 16(3) states that input tax credit shall not be allowed on the tax component if the depreciation on the tax component is claimed under the provision of Income Tax Act, 1961 by the taxable person.

Q 9. What is the maximum time limit to claim the Input tax credit?

Ans. A taxable person shall not be entitled to take input tax credit in respect of any supply of goods or services after the earlier of following two events:

- Filing of the return under section 34 for the month of September following the end of financial year to which such invoice or invoice relating to such debit note pertains
- Furnishing of the relevant annual return

Apportionment of credit and blocked credits (Section 17)

Q 10. Is proportionate credit for capital goods allowed for business and non-business purpose under the Revised Model GST Law?

Ans. In terms of section 17(1) of the Revised Model GST Law, the goods used by the registered taxable person partly for the purpose of any business and partly for other purposes, the amount of credit shall be restricted to so much of the input tax as is attributable to the purposes of his business. Implying, proportionate credit for capital goods is allowed for business and non-business purpose under the Revised Model GST Law.

Q 11. Is there any option to the Banking Company or a Financial Institution engaged in accepting deposits or extending loans or advances with respect to availment of input tax credit?

Ans. Yes, there is an option either to avail eligible input tax credit to the extent of taxable supplies including zero rated supplies or avail every month an amount equal to fifty percent of eligible input tax credit on inputs, capital goods and input services in that month.

Q 12. Whether the above option can be withdrawn in between the financial year?

Ans. The option once exercised by the Banking Company or a Financial Institution cannot be withdrawn during the remaining part of the financial year.

Q 13. Whether input tax credit available on taxable goods, which are given as free as, gift under the sales promotion?

Ans. Section 17(4) (g) states that input tax credit shall not be available in case of goods lost, stolen, destroyed, written off or disposed by way of gift or free samples.

Q 14. Whether input tax credit is allowed on inputs, which become waste and is sold as scrap?

Ans. Section 17(4) (g) states that input tax credit shall not be available in case of goods lost, stolen, destroyed, written off or disposed by way of gift or free samples. Therefore, input tax paid on taxable goods which becomes waste and is sold as scrap is not eligible.

Q 15. Whether Input destroyed/pilfered and shortage also is covered?

Ans. Section 17(4) (g) states that input tax credit shall not be available in case of goods lost, stolen, destroyed, written off or disposed by way of gift or free samples. Therefore

input tax paid on taxable goods, which are destroyed/ pilfered, and shortage is not eligible.

Q 16. Whether Input tax credit is available in respect of Input tax paid on use of mobile phones/laptops/as given to employees?

Ans. Yes, provided that the mobile phones/laptops as given to employees is used for providing taxable supply used in or in relation to the supply of taxable goods.

Q 17. Whether input tax paid on Motor vehicle and other conveyances which is used for courier agency, outdoor catering, pandal and shamiana and tour operator is eligible?

Ans. The input tax credit shall not be available in respect of Motor Vehicle and other conveyances except when they are used for further supply of such vehicles or conveyances or transportation of passengers or imparting training or for transportation of goods. Therefore, input tax credit shall be available when it is used by courier agency, outdoor catering, pandal and shamiana and tour operator as it can be considered as transportation of goods/ transportation of passengers.

Q 18. If any goods and services are to be purchased by a company as per mandatory legal requirement for benefit of employees will input tax credit be available for health insurance for all employees as per Factories Act?

Ans. Section 17(4) (b)(iii) states that input tax credit of rent a cab, life insurance, health insurance will be eligible where the Government notifies such services are obligatory for an employer to provide to its employees under any law for the time being in force.

Q 19. Whether taxes paid on change of interiors of service apartment is eligible for input tax credit?

Ans. The input tax credit is not available on goods or services received by a taxable person for construction of an immovable property on his own account other than plant and machinery even when used in course or furtherance of business. The word "construction" includes reconstruction, renovation, additions or alterations or repairs to the extent of capitalization to the said immovable property. If the cost of interiors is capitalized towards the cost of immovable property then it forms part of the cost of immovable property (Service apartment) and accordingly taxes paid on change of interiors of service apartment is not eligible for input tax credit.

Q 20. Whether input tax credit can be availed in case of goods which are detained and seized by the department when the goods are in transit under section 89 or there is confiscation of goods and or conveyances and levy of penalty under section 90 of the CGST Law?

Ans. No input tax credit cannot be availed by the taxable person in case of goods which are detained and seized by the department when the goods are in transit as specified

under section 89 of the CGST Law, or if there is confiscation of goods and or conveyances and there is levy of penalty under section 90 of the CGST Law

Availability of Credit in special circumstances (Section 18)

Q 21. Whether input tax credit can be availed on input services and capital goods when there is application for new registration or during voluntary registration under section 18?

Ans. No, input tax credit cannot be availed on the input services and capital goods as section 18(1) and section 18(2) states that input tax credit shall be available only on the stock held (inputs, inputs contained in semi-finished goods or finished goods) on the day immediately preceding the date from which he becomes liable to pay tax or preceding the date of grant of registration.

Q 22. What is the difference between the availment of credit in case of Compulsory Registration and Voluntary Registration?

Ans. In case of application for compulsory registration the input tax credit on stocks can be availed on the day immediately preceding the date from which he becomes liable to pay tax under the provisions of this Act and in case of application for voluntary registration the input tax credit on stocks can be availed on the day immediately preceding the date of grant of registration under the provisions of the Revised Model GST Law.

Q 23. In case of change of scheme from composition scheme to Regular scheme whether input tax credit on capital goods is eligible.

Ans. Under the Revised Model GST law the composition dealer is not entitled for input tax credit and the permission of scheme stand withdrawn from the day on which aggregate turnover exceed fifty lakh rupees. As per section 18(3) of the Revised GST Law, the taxable person is entitled for input tax credit even on capital goods on the day immediately preceding the date from which he becomes liable to pay tax under the Regular scheme. The credit of capital goods shall stand reduced by such percentage as may be prescribed.

Q 24. When an exempt supply becomes taxable supply then in such case credit on inputs and capital goods exclusively used for such exempted supply is eligible. What about input tax credit pertaining to capital goods used for both taxable and exempt supply?

Ans. Section 18(4) states where an exempt supply of goods or services by a registered taxable person becomes a taxable supply the input tax credit in respect of capital goods exclusively used for such exempt supply on the day immediately preceding the date from which it becomes taxable shall be eligible subject to reduction by such percentage points as may be prescribed. Therefore, based on the analysis of the above section input tax credit reduction pertaining to capital goods used for both taxable and exempt supply is not applicable.

Q 25. When there is change in the constitution of registered taxable person without specific provision of transfer of liabilities is it possible to transfer unutilized input tax credit?

Ans. No, because section 18(6) states that when there is change in constitution of the business with the specific provision of transfer of liabilities then in that instance it is possible to transfer unutilized input tax credit.

Q 26. Where a supplier transfers a running business as a whole either due to sale, merger, amalgamation of such business, whether the portion of the un-availed input tax credit in the hands of the supplier can be claimed immediately by the Recipient?

Ans. There is no specific provision as specified in the Revised Model GST Law but it can be analyzed that the recipient should be registered dealer under the Revised GST law and if he is not registered then fresh application should be made for registration and it has to be intimated to the department of such un-availed excess input tax credit.

Q 27. In case of switchover from taxable to exempt transactions or from Regular to composition whether input tax credit is fully restricted?

Ans. Based on Section 18(7) of the Revised Model GST Law the taxable person should pay the input tax credit already availed to the extent of credit in stock and on capital goods as reduced by percentage as prescribed and balance input tax credit in electronic credit ledger will lapse. The taxable person can pay by way of debit to electronic credit ledger or electronic cash ledger. Therefore in case of switchover the input tax credit is fully restricted.

Q 28. Whether Input tax credit availed on capital goods is to be reversed in case of supply of such capital goods?

Ans. As per Section 18(10) of CGST Law, in case of supply of capital goods or plant and machinery, on which input tax credit has been taken, registered taxable person shall pay an amount equal to

- The Input tax credit taken on the said capital goods or plant and machinery reduced by the percentage points as may be specified in this behalf or
- the tax on the transaction value of such goods whichever is higher

Q 29. Whether Input tax credit availed on refractory bricks, moulds and dies, jigs and fixtures is to be reversed in case of supply of such goods?

Ans. As per Section 18(10) of CGST Act, in case of supply of such goods as scrap the registered taxable person shall pay the tax on the transaction value of such goods.

Recovery of Input Tax credit and Interest thereon (Section 19)

Q 30. Whether recovery provisions can be initiated in case of wrong availment of credit?

Ans. Based on section 19 of the CGST Act if the credit has been taken wrongly, the same shall be recovered from the registered taxable person along with the interest in accordance with the provisions of this Act.

Taking input tax credit in respect of inputs sent for job work (Section 20)

Q 31. What is the time limit beyond which the inputs/capital goods sent for job work shall be treated as supply?

Ans. If the inputs/capital goods are sent to job worker the principal is entitled for input tax credit subject to the condition that, such goods / capital goods are returned within one year/three year respectively from the date of inputs/Capital goods sent to job worker. In case the goods sent for job works are not returned within specified time then such goods sent for job work shall be treated as supply.

Q 32. Whether the principal is entitled to take input tax credit even when the principal has not received the goods and directly sent to job worker by the vendor?

Ans. Yes, the principal is also entitled to take input tax credit even when the principal has not received the goods and are directly sent to job worker by the vendor.

Q 33. Whether time limit of one year or three years in case of goods sent for job work is applicable to moulds and dies, jigs and fixtures or tools sent out to job worker.

Ans. The time limit of one year or three years is not applicable to moulds and dies, jigs and fixtures or tools sent out to job worker.

Manner of distribution of credit by the Input service distributor (Section 21)

Q 34. Whether the Input service distributor and the recipient situated in different states should have same PAN or different PAN number?

Ans. Explanation 2 to Section 21(3) states that recipient of credit means supplier of goods and or services having the same PAN as that of Input Service Distributor. Therefore, the distributor and the recipient situated in different states should have same PAN number.

Q 35. What is the manner in which Input Service Distributor should distribute the credit where distributor and recipient are located in different states?

Ans. The distribution of credit to be done in following manner:
CGST, as CGST and IGST

SGST, as SGST and IGST

IGST, as IGST or CGST

Q 36. What is the manner in which Input Service Distributor should distribute the credit where distributor and recipient being business vertical are located in same states?

Ans. The distribution of credit to be done in following manner:

CGST and IGST as CGST

SGST and IGST as SGST

Q 37. Whether CGST can be distributed as SGST and whether SGST can be distributed as CGST within the states and between the states?

Ans. No, based on section 21 of the CGST Law, CGST cannot be utilized against SGST and SGST cannot be utilized against CGST within the states and between the states.

Q 38. What are the conditions applicable to Input service distributor to distribute the credit?

Ans. The conditions are as under:

- The credit should be distributed against a prescribed document
- The amount of credit distributed shall not exceed the amount of credit available for distribution
- The credit of tax paid on input service attributable to a recipient of credit shall be distributed only to that recipient.
- If credit is applicable to more than one recipient then it shall be attributable to such distribution on pro rata basis to the aggregate turnover of such recipients
- If credit is applicable to all recipients then it shall be attributable to such distribution on pro rata basis to the aggregate turnover of all such recipients

Manner of Recovery of Credit distributed in excess (Section 22)

Q 39. Whether recovery provisions can be initiated in case of wrong distribution of credit?

Ans. Based on section 22 of the CGST Law if the credit has been distributed wrongly the same shall be recovered from the registered taxable person along with the interest in accordance with the provisions of the CGST Law.

Chapter V

Registration

FAQ

(Note – Registration Rules referred was issued under Model GST Law and may be revised in near future)

Q 1. If a person is operating in different states, with the same PAN number, can he operate with a single Registration?

Ans. No. Every person who is liable to take a Registration will have to get registered separately for each of the States where he has a business operation and is liable to pay GST in terms of Sub-section (1) of Section 23 of Revised Model GST Law.

Q 2. What is the time limit for taking registration under Revised Model GST Law?

Ans. Within 30 days from the date on which he becomes liable to registration in such manner and subject to such conditions as may be prescribed.

Q 3. Whether a person having multiple business verticals in a state can obtain different registrations for each of such vertical?

Ans. Yes. In terms of Sub-Section (2) of Section 23, a person having multiple business verticals in a State may obtain a separate registration for each business vertical, subject to such conditions as may be prescribed.

Q 4. Is there a provision for a person to get himself voluntarily registered though he may not be liable to pay GST?

Ans. Yes. In terms of Sub-section (3) of Section 23, a person, though not liable to be registered under Schedule V, may get himself registered voluntarily, and all provisions of this Act, as are applicable to a registered taxable person, shall apply to such person.

Q 5. Is possession of a Permanent Account Number (PAN) mandatory for obtaining a Registration?

Ans. Yes. Every person should have a Permanent Account Number issued under the Income Tax Act, 1961 (43 of 1961) in order to be eligible for grant of registration under Section 23 of the Model GST Law.

However, as per section 23 (5) of Revised Model GST Law, PAN is not mandatory for a non-resident taxable person who may be granted registration on the basis of any other document as may be prescribed.

Q 6. Whether the Department through the proper officer, can suo-moto proceed with registration of a Person under this Act?

Ans. Yes. In terms of sub-section (6) of Section 23, where a person who is liable to be registered under this Act fails to obtain registration, the proper officer may, without prejudice to any action that is, or may be taken under the Revised Model GST Law, or under any other law for the time being in force, proceed to register such person in the manner as may be prescribed.

Q 7. Whether the proper Officer can reject an Application for Registration?

Ans. Yes. In terms of sub-section (8) of section 23 of Revised Model GST Law, the proper officer can reject an application for registration or for unique identity number after due verification. However, the proper officer shall not reject the application for registration or the Unique Identity Number without giving a notice to show cause and without giving the person a reasonable opportunity of being heard.

Q 8. Whether the Registration granted to any person is permanent?

Ans. Yes, except for non-resident and casual taxable person, the registration Certificate once granted is permanent unless surrendered, cancelled, suspended or revoked.

Q 9. Is it necessary for the foreign embassy's to get registration under Model GST Law?

Ans. All UN bodies, Consulate or Embassy of foreign countries and any other class of persons, so notified, would be required to obtain a unique identification number (UIN) from the GST portal. This UIN will be needed for claiming refund of taxes paid by them and for any other purpose as may be prescribed in the GST Rules.

Q 10. What is the responsibility of the taxable person supplying to UN bodies?

Ans. The taxable supplier supplying to these organizations is expected to mention the UIN on the invoices and treat such supplies as supplies to another registered person (B2B) and the supplier will upload the invoices of the same.

Q 11. Can a person without GST registration claim ITC and collect tax?

Ans. No. A person without GST registration can neither collect GST from his customers nor claim any input tax credit of GST paid by him.

Q 12. What will be the effective date of registration?

Ans. Where the application for registration has been submitted within thirty days from the date on which the person becomes liable to registration, the effective date of registration shall be date of his liability for registration.

Where the applicant has submitted an application for registration after thirty days from the date of his becoming liable to registration, the effective date of registration shall be the date of grant of registration.

In case of suo moto registration, i.e. taking registration voluntarily while being within the threshold exemption limit for paying tax, the effective date of registration shall be the date of order of registration.

Q 13. Who are the persons liable to take a Registration under the Revised Model GST Law?

Ans. Any supplier who carries on any business at any place in India and whose aggregate turnover exceeds threshold limit as prescribed in a year is liable to get himself registered. However, certain categories of persons mentioned in Schedule V of Model GST Law are liable to be registered irrespective of this threshold.

Further, following persons shall not be liable to registration:-

- (a) An agriculturist, for the purpose of agriculture.
- (b) Any person engaged exclusively in the business of supplying goods and/ services that are not liable to tax or are wholly exempt from tax under the Act.

Q 14. What is aggregate turnover?

Ans. As per section 2 (6) of the Revised Model GST Law, aggregate turnover includes the aggregate value of all taxable supplies, exempt supplies, export of goods and/ or services and inter-State supplies of a person having same PAN, to be computed on all India basis and excludes taxes, if any charged under CGST/SGST and IGST Act as the case may be.

Aggregate turnover does not include value of inward supplies on which tax is payable on reverse charge basis and the value of inward supplies.

Q 15. Which are the cases in which registration is compulsory?

Ans. As per paragraph 6 in Schedule V of the Model GST Law, the following categories of persons shall be required to be registered compulsorily irrespective of the threshold limit:

- (a) persons making any inter-State taxable supply;
- (b) casual taxable persons;
- (c) persons who are required to pay tax under reverse charge;
- (d) non-resident taxable persons;
- (e) an electronic commerce operator for whom the provision of section 8(4) of Mode GST Law apply.
- (f) persons who are required to deduct tax under section 46;
- (g) persons who are required to collect tax under section 56;
- (h) persons who supply goods and/or services on behalf of other registered taxable persons whether as an agent or otherwise;

- (i) input service distributor;
- (j) persons who supply goods and/or services, other than supplies specified u/s 8(4) of MGL, through such electronic commerce operator who is required to collect tax at source u/s 56;
- (k) every electronic commerce operator;
- (l) every person supplying online information and database access or retrieval services from a place outside India to a person in India, other than a registered taxable person;
- (m) such other person or class of persons as may be notified by the Central Government or a State Government on the recommendations of the Council

Q 16. Is it necessary for the Govt. organization to get registration?

Ans. Yes, in case the government organizations are required to deduct tax at source u/s 46 of MGL, shall mandatorily obtain registration under the Act. Otherwise, they shall be allotted a UIN.

Q 17. Who is a Casual Taxable Person?

Ans. Casual Taxable Person has been defined in Section 2 (20) of Revised Model GST Law. It means a person who occasionally undertakes transactions in a taxable territory where he has no fixed place of business.

Q 18. Who is a Non-resident Taxable Person?

Ans. A taxable person residing outside India and coming to India to occasionally undertake transaction in the country but has no fixed place of business in India is a non-resident taxable person in terms of Section 2 (68) of the Revised Model GST Law.

Q 19. What is the validity period of the Registration certificate issued to a Casual Taxable Person and non-resident taxable person?

Ans. The certificate of registration issued to a "casual taxable person" or a "non-resident taxable person" shall be valid for a period specified in the application for registration or for a period of 90 days from the effective date of registration, whichever is earlier. However, the proper officer, at the request of the said taxable person, may extend the validity of the aforesaid period by a further period not exceeding ninety days.

Q 20. Is there any Advance tax to be paid by a Casual Taxable Person and Non-resident Taxable Person at the time of obtaining registration under this Special Category?

Ans. Yes. A casual taxable person or a non-resident taxable person shall, at the time of submission of application for registration under sub-section (1) of section 23, make an advance deposit of tax in an amount equivalent to the estimated tax liability of such person for the period for which the registration is sought. If registration is to be

extended beyond the initial period of ninety days, an advance additional amount of tax equivalent to the estimated tax liability is to be deposited for the period for which the extension beyond ninety days is being sought.

Q 21. Whether Amendments to the Registration Certificate is permissible?

Ans. Yes, in terms of Section 25 of the Revised Model GST Law read with Draft Registration Rules, the registered taxable person shall submit an application electronically, duly signed, in FORM GST REG-11, electronically, along with documents relating to such change at the Common Portal either directly or through a Facilitation Centre, notified by the Board or Commissioner within 15 days of such change. The proper officer may, on the basis of information furnished either by the registrant or as ascertained by him, approve or reject amendments in the registration particulars in the manner and within 15 common working days from date of receipt of application or within 7 days from receipt of clarification, information or documents furnished by the applicant, where application was found incomplete and a notice was served within 15 common working days from date of receipt of application.

It is to be noted that permission of the proper officer for making amendments will be required for only certain core fields of information, whereas for the other fields, the registrant can himself carry out the amendments.

Q 22. Whether Cancellation of Registration Certificate is permissible?

Ans. Yes. Any Registration granted under this Act may be cancelled by the Proper Officer, in circumstances mentioned in Section 26 of the Revised Model GST Law. The proper officer may, either on his own motion or on an application filed by the registered taxable person in the prescribed manner or by his legal heirs, in case of death of such person, cancel the registration, in such manner and within such period as may be prescribed.

Q 23. Whether cancellation of Registration under CGST Act means cancellation under SGST Act also?

Ans. Yes. The cancellation of registration under one Act (say CGST Act) shall be deemed to be a cancellation of registration under the other Act (i.e. SGST Act). (Section 26 (6)).

Q 24. Can the proper Officer Cancel the Registration on his own?

Ans. Yes, in certain circumstances specified under section 26(2) of the Revised Model GST Law, the proper officer can cancel the registration on his own. Such circumstances include not filing return for a continuous period of six months (for a normal taxable person) or three months (for a compounding taxpayer), and not commencing business within six months from the date of registration (in case of voluntary registration). However, before cancelling the registration, the proper officer shall give reasonable opportunity of being heard. (Section 26 (4)).

Q 25. What happens when the registration is obtained by means of willful mis-statement, fraud or suppression of facts?

Ans. In such cases, the registration may be cancelled with retrospective effect by the proper officer. Section 26(3).

Q 26. Is there an option to take centralized registration for services under Model GST Law?

Ans. No.

Q 27. If the taxpayer has different business verticals in one state, will he have to obtain separate registration for each such vertical in the state?

Ans. No, it is not mandatory, however the taxpayer has the option to register such separate business verticals independently in terms of Section 23(2) of Model GST Law.

Q 28. Will ISD be required to be separately registered other than the existing taxpayer registration?

Ans. Yes. The ISD registration is for one office of the taxpayer which will be different from the normal registration irrespective of the threshold.

Q 29. Can a taxpayer have multiple ISDs?

Ans. Yes. Different offices of a taxpayer can apply for ISD registration.

Q 30. What could be the liabilities (in so far as registration is concerned) on transfer of a business?

Ans. The transferee or the successor shall be liable to be registered with effect from such transfer or succession and he will have to obtain a fresh registration with effect from such date. (Schedule V of Revised Model GST Law).

Q 31. Whether all assesses /dealers who are already registered under existing central excise/service tax/ vat laws will have to obtain fresh registration?

Ans. No. Every person registered under an earlier law and having a Permanent Account Number issued under the Income Tax Act, 1961 shall be granted registration on a provisional basis and a certificate of registration incorporating the Goods and Services Tax Identification Number (GSTIN) therein, shall be made available on the Common Portal. Further, the proper officer will issue a final registration certificate after calling for information and documents. And such information has to be submitted within 6 months or extended period.

Q 32. Whether the job worker will have to be compulsorily registered?

Ans. No. Section 55 of the Revised Model GST Law does not prescribe any such condition. Further, if aggregate turnover of such job-worker exceeds the threshold, then he has to obtain registration.

Q 33. At the time of registration will the assessee have to declare all his places of business?

Ans. Yes. The principal place of business and place of business have been separately defined under section 2(74) & 2(77) of the Revised Model GST Law respectively. The taxpayer will have to declare the principal place of business as well as the details of additional places of business in the registration form.

Q 34. Whether application for registration to be submitted manually or electronically?

Ans. The application must be filed electronically on the common portal. Taxpayers would have the option to sign the submitted application using valid digital signatures (if the applicant is required to obtain DSC under any other prevalent law then he will have to submit his registration application using the same). For those who do not have a digital signature, alternative mechanisms will be provided in the GST Rules on Registration.

Q 35. What is the time limit within which the application for registration be approved?

Ans. The proper officer shall approve the application submitted within the time limit prescribed under section 23, within 3 common working days. If the proper officer finds that the application filed under the Act is deficient, then he may call for further clarification on the information or documents submitted within 3 common working days from the filing of application. If such additional data is provided within 7 common working days, the proper officer shall approve the application within 7 common working days of receiving such data. If the proper officer doesn't approve the application within 3 or 7 days, then it shall be deemed that the registration is approved within 3 or 7 days as the case maybe.

Q 36. Can the registration certificate be downloaded from the GSTN portal?

Ans. In case registration is granted, applicant can download the Registration Certificate from the GST common portal.

Q 37. Cancellation of voluntary registration u/s 23(3)

Ans. The proper officer may cancel such registration u/s 26(2)(d) if the person who has voluntarily registered, doesn't commence the business within 6 months for the date of registration. The registered person himself may apply for cancellation of registration only after the expiry of 1 year from the grant of registration.

Q 38. Can any one of the business verticals, which are required to be registered under the Act, of a taxable person take registration as a person paying tax u/s 9?

Ans. No. If any 1 business vertical of a taxable person becomes ineligible for paying tax u/s 9, then all other business verticals of the said taxable person shall become ineligible for paying tax u/s 9.

Q 39. When will a non-resident become liable for registration?

Ans. A non-resident taxable person shall apply for registration at-least 5 days prior to commencement of business. Such person shall be allotted a temporary identification number for making the payment of estimated tax liability.

Q 40. Can cancellation of registration be revoked?

Ans. When a proper officer on his own account cancels a registration of a taxable person, then such person shall apply for revocation of such cancellation to such proper officer within 30 days from the date of service of cancellation of registration. No revocation is possible for cancellation on account of non-filing of returns unless such return is filed and the tax thereon is paid along with applicable interest, penalty and late fee. If the proper officer is satisfied of the application & document filed by the person, then such officer may revoke the cancellation of the registration within such period as prescribed upon receipt of such application of revocation.

The proper officer may call for further details and clarification within such period as prescribed upon filing the application. The proper officer cannot reject the application for revocation without giving the person a reasonable opportunity of being heard.

Q 41. Can a person who is not required to be registered under GST Act but registered under the earlier law, cancel the provisional registration?

Ans. Yes, but the time limit is not mentioned for applying for cancellation of provisional registration.

Q 42. Should a casual taxable person or non-resident taxable person apply for registration in every state from which that person is operating or is the registration common for all the states?

Ans. In terms of section 24(2) read with Section 23(1) such persons need to obtain a separate registration in every such States.

Q 43. From which state the taxable person should obtain registration?

Ans. A taxable person should obtain registration in every State from which he intends to make the supply the good(s) and/or service(s).

Q 44. If the job-worker subsequently registers, should the principal amend his registration by cancelling the job-workers premises as his additional place of business?

Ans. Yes

Q 45. Does cancellation of registration have any effect on the tax liability of the person whose registration has been cancelled?

Ans. Cancellation of registration does not affect the tax liability of the person which is incurred prior to the date of cancellation. He shall still be liable to pay the amount of tax and other dues or any other obligation for a period prior to the date of cancellation.

Q 46. What are the effects of cancellation of registration on input tax credit in respect of inputs held in stock, contained in semi-finished and finished goods and capital goods?

Ans. Every registered taxable person whose registration has been cancelled shall either reverse or pay the amount of ITC on inputs which are held in stock or inputs contained in semi-finished or finished goods held in stock on the day immediately preceding the date of such cancellation or the output tax payable on such inputs whichever is higher to be calculated in a manner as prescribed.

In case of capital goods, the person shall pay the ITC claimed on such capital goods reduced by such percentage points as maybe prescribed in this behalf or tax on transaction value whichever is higher.

Q 47. Who can be the primary authorized signatory?

Ans. A Primary authorized signatory is the person who is primarily responsible to perform action on the GST System Portal on behalf of taxpayer. All communication from the GST System Portal relating to taxpayer will be sent to him. He may be resident or non-resident.

Q 48. Whether a person who is registered is liable to collect and remit the tax even though his aggregate turnover does not exceed threshold limit of ₹ 20 Lakhs/ 10 Lakhs as the case may be?

Ans. Yes. As there is no provision under the MGL exists to provide for exemption to such cases.

Q 49. Which are all the states specified under Article 279A (4)(g) of the Constitution?

Ans. States of Arunachal Pradesh, Assam, Jammu and Kashmir, Manipur, Meghalaya, Mizoram, Nagaland, Sikkim, Tripura, Himachal Pradesh and Uttarakhand.

Q 50. Within how many days the amendments to registration to be intimated?

Ans. In terms of Draft Registration Rules, the registered taxable person shall intimate amendments to registration by submitting an application electronically in Form GST REG-1 along with supporting documents, within 15 days of the change in any particulars furnished in the application for registration submitted either at the time of obtaining registration or as amended from time to time.

Q 51. Whether registered taxable person required to display his certificate of registration?

Ans. Every registered taxable person shall display his registration certificate in a prominent location at his principal place of business and at every additional place of business. Further, he has to display his GSTIN in the name board exhibited at the entry of his principal place of business and at every additional place of business.

MCQ

Q 1. How is the aggregate turnover of ₹ 20 Lakh is calculated?

- (a) Aggregate value of all taxable supplies, exempt supplies, export of goods/services and interstate supplies of a person having same PAN computed on all India basis.
- (b) Aggregate value of all taxable supplies, exempt supplies, export of goods/services and interstate supplies of a person computed for each state separately.
- (c) Aggregate value of all taxable intrastate supplies, export of goods/services and exempt supplies of a person having same PAN computed for each state separately.
- (d) Aggregate value of all taxable supplies, exempt supplies, export of goods/services and interstate supplies of a person having same PAN computed on all India basis and excluding taxes if any charged under CGST Act, SGST Act and IGST Act.

Ans. (d) Aggregate value of all taxable supplies, exempt supplies, export of goods / services and interstate supplies of a person having same PAN computed on all India basis and excluding taxes if any charged under CGST Act, SGST Act and IGST Act.

Q 2. Whether all persons are mandatorily required to obtain registration?

- (a) Yes
- (b) Not required if he is an agriculturist or person exclusively engaged in supplying exempt goods or services and for others if specified threshold limit exceeds in a financial year.
- (c) Not required if he is an agriculturist or person exclusively engaged in supplying exempt goods or services.
- (d) No, only if specified threshold exceeds in a financial year then only need to obtain.

Ans. (b) Not required if he is an agriculturist or person exclusively engaged in supplying exempt goods or services and for others if specified threshold limit exceeds in a financial year.

Q 3. In terms of Section 23 of the Revised Model GST Law read with Schedule V, which one of the following is true?

- (a) A person can't collect tax unless he is registered.
- (b) Registered person not liable to collect tax till his aggregate turnover exceeds ₹ 20 lakhs/ ₹ 10 Lakhs as the case may be.

- (c) A person can collect the tax during the period of his provisional registration.
- (d) Both (a) and (b) are correct.

Ans. (d) Both (a) and (b) are correct.

Q 4. Which of the following forms are used for registration?

- (a) Form GSTR -1
- (b) Form GSTR – 2
- (c) Form GST REG-01
- (d) Form GST REG

Ans. (c) Form GST REG-01

Q 5. Within how many days a person should apply for registration?

- (a) Within 60 days from the date he becomes liable for registration.
- (b) Within 30 days from the date he becomes liable for registration.
- (c) No Time Limit
- (d) Within 90 days from the date he becomes liable for registration.

Ans. (b) Within 30 days from the date he becomes liable for registration

Q 6. A person havingbusiness verticals in a State obtain a separate registration for each business vertical.

- (a) Single, shall
- (b) Multiple, shall
- (c) Multiple, may
- (d) Single, May

Ans. (c) Multiple, May

Q 7. Which one of following statements are correct?

- (a) Voluntary registration is not possible.
- (b) Voluntarily registered person not liable to comply with all the provisions.
- (c) A person may get himself registered voluntarily and shall comply with all the provisions.
- (d) None of the above.

Ans. (c) A person may get himself registered voluntarily and shall comply with all the provisions.

- Q 8. PAN issued under the Income Tax Act is mandatory for grant of registration.
- (a) It is one of the document listed.
 - (b) Yes, but non-resident taxable person may be granted registration on the basis of any other document.
 - (c) No, for persons who are required to deduct tax at source u/s 46 shall have TAN in lieu of PAN.
 - (d) Both (b) and (c)

Ans. (d) Both (b) and (c)

- Q 9. An E-commerce operator should get registered irrespective of his threshold limit?
- (a) Yes
 - (b) No, required to register only if his aggregate turnover exceeds the threshold limit.
 - (c) Yes, if he is located in Northwestern states.
 - (d) He is required to register if he is liable to collect tax at source and his aggregate turnover exceeds the threshold limit.

Ans. (a) Yes

- Q 10. What is the validity of the registration certificate?

- (a) One year
- (b) No validity
- (c) Valid till it is cancelled.
- (d) Five years.

Ans. (c) Valid till it is cancelled.

- Q 11. Which of the following statements are correct?

- (a) Persons who are required to deduct tax u/s 46 shall obtain registration irrespective of the threshold specified.
- (b) Persons who are required to collect tax u/s 56 shall obtain registration irrespective of the threshold specified.
- (c) Every electronic commerce operator shall obtain registration irrespective of the threshold specified.
- (d) Persons who required to pay tax u/s 8(4) shall obtain registration irrespective of the threshold specified.

Ans. All the above statements are correct.

- Q 12. A person is not required to obtain registration if he is required to pay tax under reverse charge and there are no taxable supplies made by him.
- (a) Incorrect, if person who are required to pay tax under reverse charge, irrespective of threshold shall obtain registration.
 - (b) Incorrect, if person who are required to pay tax under reverse charge obtain registration only if such value of supplies under reverse charge exceeds the threshold limit.
 - (c) Above statement is correct.
 - (d) A person is required to obtain registration if he is required to pay tax under reverse charge and also he is also making taxable supplies irrespective of the threshold limit.

Ans. (a) Incorrect, if person who are required to pay tax under reverse charge, irrespective of threshold shall obtain registration.

- Q 13. What is the validity of the registration certificate issued to casual taxable person and non-resident taxable person?
- (a) 90 days from the effective date of registration
 - (b) Period specified in the application for registration
 - (c) Earliest of (a) or (b) above
 - (d) 180 days from the effective date of registration.

Ans. (c) Earliest of (a) or (b) above

- Q .14 Which of the following requires amendment in the registration certificate?
- (a) Change of name of the registered person
 - (b) Change in constitution of the registered person
 - (c) Switching over from composition scheme to normal scheme or vice versa.
 - (d) All of the above

Ans. (d) All of the above

- Q .15 When can a voluntarily registered person's registration be cancelled?
- (a) If the person does not start business within six months from the date of registration.
 - (b) Business has been discontinued or transferred for any reason.
 - (c) Non-filing of returns for a continuous period of six months or for three consecutive tax period in case of composite dealer.
 - (d) All of the above

Ans. (d) All of the above

Q .16 What are the consequences of obtaining registration by misrepresentation?

- (a) Liable to cancellation of registration by proper officer.
- (b) Liable to fine not exceeding ₹ 1,000,000/-
- (c) Imprisonment for a period of 6 months to 3 years.
- (d) Both (b) and (c)

Ans. (a) Liable to cancellation of registration by proper officer.

Q 17 Does cancellation of registration under CGST affect the liability under SGST/IGST for period prior to cancellation of registration?

- (a) Cancellation of registration will immune his liability under CGST only.
- (b) Cancellation of registration will immune his liability under IGST only.
- (c) Cancellation of registration will immune his liability under SGST and CGST but not under IGST.
- (d) Cancellation does not affect the liability of taxable person to pay tax and other dues under CGST/SGST/IGST Act.

Ans. (d) Cancellation does not affect the liability of taxable person to pay tax and other dues under CGST/SGST/IGST Act.

Q 18. Within how many days an application for revocation of cancellation of registration can be made?

- (a) Within 7 days from the date of service of the cancellation order.
- (b) Within 15 days from the date of issue of the cancellation order.
- (c) Within 45 days from the date of issue of the cancellation order.
- (d) Within 30 days from the date of service of the cancellation order.

Ans. (d) Within 30 days from the date of service of the cancellation order.

Q 19. Which of the following statements are incorrect?

- (a) Revocation of cancellation of registration under CGST/SGST Act shall be deemed to be a revocation of cancellation of registration under SGST/CGST Act.
- (b) Cancellation of registration under CGST/SGST Act shall be deemed to be a cancellation of registration under SGST/CGST Act.
- (c) Revocation of cancellation of registration under CGST/SGST Act shall not be deemed to be a revocation of cancellation of registration under SGST/CGST Act.

Ans. (c)

Q 20. How can a person submit the application for registration?

- (a) Filing FORM GST REG-01 along with necessary documents with the jurisdictional proper officer.
- (b) Filing FORM GST REG-01 electronically in the common portal and uploading the required documents along with the application.
- (c) Uploading necessary documents electronically in the common portal and also submitting manually to the jurisdictional proper officer.
- (d) None of the above

Ans. (b) Filing FORM GST REG-01 electronically in the common portal and uploading the required documents along with the application.

Q 21. Where the application for grant of registration has been approved, a certificate of registration in shall be made available to the applicant on the

- (a) FORM GST REG-06, Common Portal
- (b) FORM GST CER-06, Common Portal
- (c) FORM GST CER-06, Jurisdictional office
- (d) FORM GST REG-10, Company portal

Ans. (a) FORM GST REG-06, Common Portal

Q 22. Which of the below statements are incorrect in finding out the effective date of registration?

- (a) From the date on which a person becomes liable to registration, where application is submitted within 30 days from such date.
- (b) Date of grant of registration, where application is submitted after 30 days from such date.
- (c) From the date of grant of provisional registration, in case of persons registered under earlier law.
- (d) Date of issue of certificate of registration.

Ans. (d) Date of issue of certificate of registration.

Q 23. Can a person apply for registration to pay tax u/s 9 for any of his business verticals at his choice?

- (a) Yes, irrespective of the registration status of other business verticals.
- (b) No. All of his other business verticals also should have obtained registration for paying tax under section 9.

- (c) Yes, provided majority of the business verticals are paying under section 9.
- (d) Yes, if all the business vertical in a state are obtained registration to pay tax under section 9.

Ans. (b) No. All of his other business verticals also should have obtained registration for paying tax under section 9.

Q 24. A Unique Identity Number will be allotted to the following persons upon submitting an application:

- (a) All the taxable persons can apply.
- (b) Only unregistered persons can apply.
- (c) Specialized agency of the UNO or any multilateral financial institution or consulate or embassy of foreign countries.
- (d) No such concept under CGST/SGST Act.

Ans. (c) Specialized agency of the UNO or any multilateral financial institution or consulate or embassy of foreign countries.

Q 25 Every registered taxable person shall display his certificate of registration in a prominent location at his principal and at every other place of business also GSTIN shall be displayed on the name board at the entry of such places.

- (a) No, certificate of registration to be displayed only at a registered place of business and GSTIN need not be displayed on the name board.
- (b) Yes above statement is correct.
- (c) No, GSTIN to be displayed only on the invoices.
- (d) Above statement is correct subject to certificate of registration to be displayed only at registered place of business.

Ans. (b) Yes above statement is correct

Q 26 Under what circumstances physical verification of business premises is mandatory?

- (a) Physical verification of business premises is a discretionary power of proper officer.
- (b) If additional information for registration asked by the proper officer is not submitted within specified time.
- (c) If certificate of registration is obtained on misrepresentation of facts.
- (d) If photograph of the business premise is not uploaded in the common portal within specified time.

Ans. (a) Physical verification of business premises is a discretionary power of proper officer

Chapter - VI

Tax Invoice, Credit and Debit Notes

FAQ

(Note – Draft Invoice Rules referred was issued under Model GST Law and may be revised in near future)

Q 1. When should a Tax Invoice be issued for supply of Goods?

Ans. The answer depends upon the type of goods.

If the goods are such that movement of goods are involved, then taxable invoice has to be issued before or at the time of removal of the goods.

If supply of goods does not require movement of goods, then taxable invoice has to be issued at the time the goods are delivered to the recipient or when the goods are made available to the recipient.

Q 2. Can there be any relaxation in respect of the time allowed for issuing the invoice?

Ans. If the GST Council recommends that for specified category of goods, or for specific categories of supplies the tax invoice can be issued within a prescribed time, then the Government may issue a notification to implement such recommendation.

Q 3. How can I supply goods without movement?

Ans. There are many situations in which such a supply is possible. In such cases, the supplier should be giving up his control over the goods, even though the goods have not moved from the place in which they are.

Ex., when an Agent who is in possession of some goods decides to buy the goods on his account, there will be a delivery without any movement of the goods.

These cases will also cover assembly and delivery of machinery on site by the supplier.

Q 4. What is Removal?

Ans. Removal is defined u/s 2(85) of the Act. Removal in relation to goods means, dispatch of the goods for delivery or collection of the goods. It can be seen that removal is complete as soon as the goods are dispatched. For raising an invoice, the supplier should not wait till the goods reach the destination.

Further, the goods should be in deliverable state. Mere removal of parts for the purpose of assembly in a client's site will not constitute removal.

Q 5. Who can remove the goods?

Ans. Goods can be removed by,

- the supplier himself
- any other person acting on behalf of the supplier
- the recipient himself
- any other person acting on behalf of the recipient

Q 6. I am supplying tea/coffee three times a day to the Advocate's Office. Do I have to issue three invoices per day? Every Monday, I submit the total number of cups supplied during the previous week and I receive the payment by Wednesday.

Ans. In such cases of continuous supply of goods, invoice has to be issued at the time of submitting the statement every Monday.

Q 7. What will be the situation if, they pay me ₹ 500 every Wednesday on account and I submit them the total number of cups supplied on a monthly basis?

Ans. In such case, invoice has to be issued each time the amount of ₹ 500 is received during the month. Also, invoice has to be issued for the balance amount due at the time of submitting the bill for the month.

e.g., If total bill for the month is ₹ 2,350/-, out of which ₹ 500/- is received every week for 4 weeks, then 4 invoices has to be raised for ₹ 500/- on receipt basis and ₹ 350 on billing basis.

Q 8. Do I have to issue an invoice even if I remove goods for 'sale on approval basis'?

Ans. Yes, invoice has to be issued even if goods are removed for 'sale on approval basis' in terms of Section 28(8) of the Revised Model GST Law.

According to Section 28 thereof, where the goods (being sent or taken on approval or sale or return or similar terms) are removed before it is known whether a supply will take place, the invoice shall be issued before or at the time when it becomes known that the supply has taken place or six months from the date of removal, whichever is earlier.

Q 9. When to raise an invoice for providing Services?

Ans. Invoice has to be raised within 30 days of providing the service.

Q 10. Will any other document be accepted in lieu of a tax invoice for supply of services?

Ans. If the GST Council recommends that for a category of services, any other document should be accepted as a tax invoice, the Government may notify that such document will be deemed to be a tax invoice, subject to prescribe conditions and limitations.

Q 11. I have a contract to supply manpower to a factory for 12 months. When shall I raise the invoice?

Ans. The contract is for continuous supply of services. If the due date of payment is ascertainable from the contract, then the invoice has to be raised within 30 days of the recipient becoming liable to make the payment even though payment is not received.

Q 12. I am constructing a building for my client. The client is required to pay me on completion of plinth, 1st floor and 2nd floor. When should the invoice be raised?

Ans. Invoice has to be raised within 30 days of completion of each stage.

Q 13. I had a contract for supplying manpower for 28 days for ₹ 28,000/-. However, after 10 days, the service has stopped. When shall I raise the invoice?

Ans. Invoice has to be issued at the time when the supply ceased, i.e., on the 10th day. The invoice shall be for that much of service, which is provided.

Q 14. I am an Input Service Distributor. Are these provisions applicable to me?

Ans. The document issued by ISD for distribution is deemed to be a 'tax invoice' making these provisions applicable to an ISD, to the extent applicable.

Q 15. I am a Banking Company. Do I have any relaxation?

Ans. Yes in case of Banking Companies, Financial Institutions including NBFCs, the time for issuing an invoice is extended to 45 days from the date of Supply of Service.

Q 16. Can an Unregistered person issue a tax invoice?

Ans. No, only a registered taxable person can issue tax invoice. Also, section 29 specifically prohibits collection of tax by a person who is not a registered taxable person.

Q 17. I became liable to pay tax on 1st April. I have applied for registration on 15th April, which is within the 30 days window given to me. My registration is granted on 29th April. How will I collect tax from 1st April to 28th April?

Ans. Till the grant of registration on 29th April, tax cannot be collected on a day to day basis against the invoices raised.

However, even though the registration is granted on 29th April, the effective date of will be 1st April as registration is applied within the permissible 30 days period.

Section 28(3) which permits to issue 'revised tax invoices' against the invoices raised on a regular basis without collection of tax from 1st April to 28th April. Applicable taxes to be collected in the revised invoices issued.

Issue separate tax invoices to the following:

- registered persons
- inter-state supplies to unregistered persons if the taxable value of the supply is ₹ 2,50,000 or more.

Consolidate the supplies made between 1st and 28th April, in the following cases:

- All taxable supplies to an unregistered person during the period;

All inter-state taxable supplies of taxable value of less than ₹ 250000 made to unregistered recipients of each state

Q 18. Is it necessary for me to issue receipt for advances?

Ans. Yes. A receipt voucher or any other document containing prescribed particulars should be issued on receipt of any advance payment towards supply of goods.

Q 19. I am liable to pay tax on Reverse Charge basis for some purchases which are mostly from unregistered persons. What documentation is required in this regard?

Ans. On the supply of notified goods or services by a person who is unregistered, a Purchase 'invoice' is to be raised on the date of receipt of goods or services.

Q 20. What do you mean by Continuous Supply of Goods or Services?

Ans. U/s 2(30), Continuous supply of goods means a supply of goods which is provided or agreed to be provided continuously or on recurrent basis. There should be a contract for such supply and the supplier should be invoicing the recipient on a regular or periodic basis. Also, the supply may or may not be through a wire, cable, pipeline or other conduit.

U/s 2(31), Continuous supply of services means, supply of service which is provided or agreed to be provided continuously or on recurrent basis. There should be a contract for a period exceeding 3 months. There should be periodic payment obligations.

Please note that if the Council recommends that the supply of a particular category of goods or services should be treated as 'continuous supply', the Government may issue a notification to that effect.

Q 21. What is a 'Bill of Supply'?

Ans. Bill of supply should be issued by a supplier in following cases:

- The supply is that of exempted goods or services; or
- The supplier has opted to pay tax under composition scheme

Q 22 Is it necessary to issue a 'Bill of Supply' for all supplies?

Ans. No. A 'Bill of Supply' need not be issued if the value of the goods or services is less than ₹ 100 unless the recipient demands for a bill.

However, in such case, a consolidated 'Bill of Supply' should be prepared at the close of each day in respect of all such supplies.

Q 23. What are the circumstances in which a Credit Note is to be issued?

Ans. For issuing a Credit note, an invoice for a supply should have been issued earlier and subsequently the following situations should arise,

- The taxable value on which the tax is collected is more than the actual taxable value
- The tax charged is more than what you should have charged
- The recipient has returned the goods
- The recipient has found that the services supplied by you are deficient

Q 24. I had made a supply in April. The party returned the goods in May. How will I declare the credit note to the tax authorities?

Ans. The credit note should be declared in return of outward supplies for the month of May.

Q 25. I had made a supply in April. The party returned the goods in Oct. Will I still be able to issue a Credit Note?

Ans. A credit note for old supplies can be issued provided annual return for the period during which the supply was made is not filed. Also, a credit note for any supply can be issued only up to the 30th of September following the end of the financial year in which the supply was made.

E.g. Assuming that annual return for the year 2017-18 is not filed, if the supply is made on 1st April 2017, a credit note can be issued up to 30th September 2018. However, if Annual Return is filed for financial year 2017-18 on 30th June 2018, then credit note cannot be issued after that date for the supplies made during the financial year 2017-18.

Q 26. Will my tax liability be reduced if I issue a Credit Note?

Ans. Normally, tax liability should reduce if a Credit Note is issued. However, there are certain procedural requirements before that can happen. These requirements are:

- (a) The incidence of tax and interest should have been not be passed on such supply to any other person other than the recipient to whom the credit note is issued. It may be noted that under section 44(9), it is deemed to have passed the full incidence of tax to the recipient of the goods/services.
- (b) The recipient of the supply should accept credit note in his return of inward supply and reduce his claim of input tax credit at least to the extent reduction of tax liability.

Q 27. When I reject an inward supply, can I issue a Debit Note?

Ans. For accounting purposes, you may do so. But, for the purpose of GST, such a debit note will be of no consequence. There is no concept of issue of debit note by the recipient of supplies. Under the scheme of things, both debit note and credit note are issued by the supplier only.

Q 28. So, Debit note can be issued only for increasing tax liability by the supplier?

Ans. Yes. 'Debit notes' are akin to 'supplementary invoices'. They are issued by the supplier for recording increase in taxable value or tax charged in the supply.

Q 29. I had made a supply in April. In May, the recipient decided to permit increased rate for the supply. How will I declare the debit note to the tax authorities?

Ans. Debit note in will have to be declared in the return of outward supplies for the month of May.

Q 30. Are there any restrictions on raising debit notes for earlier supplies?

Ans. No. The debit notes can be raised for earlier supplies without any restriction

Q 31. What should the contents of a tax invoice be?

Ans. Normally, the tax invoice should have the following details:

- (a) Name, address, GSTIN of the supplier
- (b) Serial Number having only alphabets / numerals
- (c) Date of Issue
- (d) Name, and address of the recipient
- (e) GSTIN/UID of the recipient, if registered
- (f) HSN code of Goods or Accounting Code of Services
- (g) Description of Goods / Services
- (h) Quantity and Unit (or Unique Quantity Code) in case of Goods
- (i) Total Value of Goods and Services
- (j) Post discount/abatement taxable value of Goods and Services
- (k) Rate of Tax, Separately for CGST & SGST or IGST
- (l) Amount of Tax Charged
- (m) Place of Supply along with the name of the state if the supply is not intra-state supply
- (n) Place of delivery if different from place of supply

- (o) Whether tax is payable on reverse charge
- (p) Signature/Digital Signature of the Supplier or his authorised representative.

Q 32. What are the additional details required in the invoice of a Goods Transport Agency?

Ans. GTA supplying services in relation to transportation of goods by road in a goods carriage, is required to have the following additional details in its invoices:

- (a) Gross weight of the consignment
- (b) Name of the Consignor and the Consignee
- (c) Registration number of the goods carriage
- (d) Details of goods transported
- (e) Details of place of origin and destination
- (f) GSTIN of the person liable to pay tax whether as consignor, consignee or GTA

Q 33. What are the contents of a 'Bill of Supply'?

Ans. A Bill of Supply should have the following details:

- (a) Name, address, GSTIN of the supplier
- (b) Serial Number having only alphabets/numerals
- (c) Date of Issue
- (d) Name, and address of the recipient
- (e) GSTIN/UID of the recipient, if registered
- (f) HSN code of Goods or Accounting Code of Services
- (g) Description of Goods / Services
- (h) Post discount/abatement value of Goods and Services
- (i) Signature/Digital Signature of the Supplier or his authorised representative.

Q 34. What are the contents of Credit Notes, Debit Notes and Supplementary Tax Invoices?

Ans. These documents shall contain the following details:

- (a) Name, address, GSTIN of the supplier
- (b) Nature of the Document
- (c) Serial Number having only alphabets/numerals
- (d) Date of Issue
- (e) Name, and address of the recipient
- (f) GSTIN/UID of the recipient, if registered
- (g) Name and address of the recipient and address of delivery, along with the name of state and its code, if such recipient is unregistered
- (h) Serial number and date of the corresponding tax invoice/bill of supply

- (i) Taxable value of goods or services, rate of tax and the amount of tax credited/debited to the recipient
- (j) Signature/Digital Signature of the Supplier or his authorised representative.

Q 35. What are the contents of invoices issued by ISD?

Ans. The tax invoice issued by an ISD shall contain the following details:

Name, address, GSTIN of the ISD

- (a) Serial Number having only alphabets/numerals
- (b) Date of Issue
- (c) Name, address, GSTIN of the supplier of input service
- (d) Serial Number and date of invoice of such supplier of input service
- (e) Name, address, GSTIN of the recipient to whom credit is being distributed
- (f) Amount of Credit Distributed
- (g) Signature/Digital Signature of the Supplier or his authorised representative.

Q 36. Are there any relaxations available for banking companies or a financial institutions including NBFC?

Ans. Yes. If a Banking Company or a Financial Institution including NBFC is an ISD, the tax invoice is deemed to include any document which may or may not be serially numbered. For remaining supply of services by these entities, in addition to the above, the address of the recipient of taxable service need to be mentioned in the document.

Q 38. What is the relaxation for Supplier of Passenger Transportation Service?

Ans. In case of such suppliers, a tax invoice will include a 'ticket'. The requirement of having the address of the recipient of taxable service on the tax invoice is also waived.

Q 39. How many copies of an invoice are required for supply of Goods?

Ans. The invoice should be prepared in triplicate. The original is for the recipient, triplicate for the supplier and the duplicate for the transporter. Duplicate copy is not required if an Invoice Reference Number is obtained. The copies should be marked as 'ORIGINAL FOR RECIPIENT', 'DUPLICATE FOR TRANSPORTER' and 'TRIPLICATE FOR SUPPLIER', as the case may be.

Q 40. What is an Invoice Reference Number?

Ans. Invoice Reference Number (IRN) can be obtained by a supplier from the Common Portal by uploading a tax invoice in Form GST INV-1.

Q 41. How will the transporter satisfy the proper officer if he checks the goods in movement unless he has a copy of the Invoice?

Ans. The IRN generated by the supplier in the common portal is valid for 30 days. It is sufficient if the IRN is produced to the proper officer instead of the printed copy of the Invoice.

Q 42. How many copies of an invoice is required for supply of services?

Ans. For supply of Services, only two copies of the invoice is sufficient. The original is for the recipient and the duplicate for the supplier.

Q 43. Can I start a fresh series of serial number for my 'invoice' or 'bill of supply' every day, e.g., 20160401-001 for April 1st and 20160402-001 for 2nd April?

Ans. The rule states that the serial number should be consecutive and unique for a financial year. Hence, restarting the serial number of the invoice or 'bill of supply' on a daily basis may not be proper.

Q 44. Can I raise an invoice to an unregistered person without any restrictions?

Ans. The name, address of the recipient and the address of delivery, along with the name of state and its code has to be mentioned in the invoice if the taxable value of supply is ₹ 50,000 or more.

Q 45. Is it compulsory to mention HSN Codes or SAC?

Ans. The Board/Commissioner by notification may specify the number of Digits of HSN code for goods or Accounting Code for Services that a class of taxable persons shall be required to mention.

Q 46. What are the special requirements of a supplementary or revised invoice?

Ans. The words Revised Invoice or Supplementary Invoice should be mentioned prominently along with reference of the date and invoice number of the original invoice.

Q 47. What are the specific requirements of an export supply?

Ans. The document should carry one of the following endorsements:

- Supply Meant For Export On Payment Of GST
- Supply Meant For Export Under Bond Without Payment Of GST

Also, the document should contain the following details of the recipient:

- Name and Address
- Address of Delivery
- Name of the country of Destination
- Number and date of application for removal of goods for export in Form ARE-1

Q 48. Can I mention a consolidated price for the supply which would include the cost of the supply and tax in the invoice?

Ans. In all the documents relating to assessment, tax invoice and other like documents, it is mandatory to mention prominently the amount of tax that forms part of the price at which the supply is made. Therefore, mentioning a consolidated amount without showing the tax separately will not be in accordance with the law.

MCQ

Q 1. Bill of Supply has to be issued for?

- (a) Supply of Exempted Services Only
- (b) Supply of Exempted Goods and Services
- (c) Supply of Exempted Goods Only
- (d) None of the above

Ans. (b) *Supply of Exempted Goods and Services*

Q 2. If the value of an exempted supply is ₹100, Bill of Supply,

- (a) Has to be issued
- (b) Need not be issued unless recipient asks for
- (c) Need not be issued even if recipient asks for
- (d) None of the above

Ans. (a) *Has to be issued*

Q 3. When a Bill of Supply has not been issued to some recipients because the value of supply is less than the prescribed limit,

- (a) Nothing further has to be done in this regard
- (b) All such supplies have to be consolidated on a daily basis
- (c) One consolidated invoice has to be issued on a monthly basis and included in return of outward supply
- (d) None of the above

Ans. (b) *All such supplies have to be consolidated on a daily basis*

Q 4. An invoice has to be issued, for the supply of goods,

- (a) When the recipient has collected the goods
- (b) When the recipient has received the goods
- (c) Either (a) or (b)
- (d) None of the above

Ans. (a) When the recipient has collected the goods

Q 5. 'Removal', in relation to goods, includes,

- (a) Dispatch of the goods by the recipient after collecting the same from the supplier to his own godown
- (b) Removal of the goods by the supplier from his godown
- (c) Collection of the goods by the recipient's agent from the supplier's agent
- (d) Both 'a' and 'c'

Ans. (c) Collection of the goods by the recipient's agent from the supplier's agent

Q 6. A supply of Goods,

- (a) Cannot be made without moving the same
- (b) Can be made without moving the same
- (c) Can be made only if the same person is buying and selling the goods in different capacities by way of legal fiction
- (d) None of the Above

Ans. (b) Can be made without moving the same

Q 7. In case of continuous supply of goods, like supplying parts to a manufacturer on a daily basis, where the billing is done monthly, but ad-hoc payment is received once every 6 days,

- (a) Invoice should be issued once in a month
- (b) The total amount due for the entire month should be divided equally in five parts and invoice is issued on 6th, 12th, 18th, 24th and 30th of the month and duly declared while filing the monthly return
- (c) Either a or b, depending upon the convenience of the parties
- (d) None of the Above

Ans. (d) None of the Above

Q 8. If, Goods are supplied on sale or return basis,

- (a) Under seamless credit concept of GST, Invoice has to be issued by the supplier while sending the goods; Another Invoice has to be issued by the recipient while rejecting the goods.
- (b) Invoice has to be issued by the supplier while sending the goods but the recipient can take credit only when the goods are accepted by him.
- (c) Invoice has to be issued when the recipient accepts the goods or six months from the date of supply whichever is earlier
- (d) Invoice has to be issued when the recipient accepts the goods or six months from the date of supply whichever is later

Ans. (c) Invoice has to be issued when the recipient accepts the goods or six months from the date of supply whichever is earlier

- Q 9. If Supply of Services has ceased under a contract before the completion of supply,
- (a) Invoice has to be issued within 30 days on the basis of 'Quantum Meruit' from the date of cessation
 - (b) Invoice has to be issued at the time of cessation to the extent of the supply effected.
 - (c) Invoice has to be issued for the full value of the contract after deducting a percentage thereof as prescribed.
 - (d) Invoice cannot be issued as the matter will be sub-judice

Ans. (b) Invoice has to be issued at the time of cessation to the extent of the supply effected

- Q 10. The period within which the invoice should be issued from the date of supply of service, is
- (a) 30 days
 - (b) 1 month
 - (c) Invoice has to be issued immediately on provision of service
 - (d) None of the above

Ans. (a) 30 days

- Q 11. A person who has applied for registration can,
- (a) Provisionally collect tax till his registration is approved because he has started paying tax on his inputs
 - (b) Neither collect tax nor pay tax on his input
 - (c) Start his business only after getting his registration
 - (d) None of the above

Ans. (d) None of the above (Different situations, different treatment will prevail)

- Q 12. An invoice should contain the name and address of the recipient and address of delivery along with name of State and its code, if such recipient is unregistered and if the value of the supply
- (a) Is more than ₹ 2,50,000
 - (b) Is ₹ 50,000 or more
 - (c) Is more than ₹ 50,000
 - (d) Is ₹ 2,50,000 or more

Ans. (b) Is ₹ 50,000 or more

Q 13. Is it necessary that each time an advance is received, a receipt is issued?

- (a) Yes
- (b) No
- (c) Only if value exceeds the prescribed limit of ₹ 1000
- (d) None of the above

Ans. (a) Yes

Q 14. If a recipient returns the goods, the supplier has to raise a

- (a) Acceptance letter
- (b) Banker's Receipt
- (c) Credit Note
- (d) Debit Note

Ans. (c) Credit Note

Q 15. The last date for issuing a Credit Note for a supply made in September 2017 is,

- (a) Last date of filing Annual Return, i.e., 31.12.2017
- (b) Last date of filing return for the month of September, i.e., 20.10.2017
- (c) Six months from the date of supply, i.e., 31.03.2018
- (d) None of the above

Ans. (d) None of the above

Q 16. In a transaction between the supplier and recipient, what is one person's credit note is another person's debit note. Therefore,

- (a) Either the recipient can enter his debit note or the supplier can enter his credit note in the portal
- (b) Filing of Credit note by the supplier will reduce his liability subject to confirmation by the recipient whereas filing of Debit note by the recipient will reduce his ITC subject to confirmation by the supplier.
- (c) Both the above
- (d) None of the above

Ans. (d) None of the above

Q 17. The last date for issuing a Debit Note for a supply made in March 2017 is,

- (a) Last date of filing Annual Return, i.e., 31.12.2017
- (b) Last date of filing return for the month of September, i.e., 20.10.2017
- (c) Six months from the date of supply, i.e., 31.03.2018

(d) No such restriction imposed.

Ans. (d) No such restriction imposed

Q 18. A tax invoice should be,

- (a) As per the prescribed format
- (b) As per the commercial needs of the supplier
- (c) In any format as long as it contains the minimum prescribed requirements
- (d) None of the above

Ans. (c) In any format as long as it contains the minimum prescribed requirements

Q 19. The amount of input tax credit availed by the supplier, should

- (a) Be mentioned prominently in the invoice so that Input Tax Credit can be passed on
- (b) Not be mentioned so that the recipient does not come to know about the cost price
- (c) Not mentioned because it is not mandatory
- (d) Mentioned for supply of goods but not for services

Ans. (c) Not mentioned because it is not mandatory

Q 20. While calculating the tax on a supply valued at ₹ 1000,

- (a) First CGST has to be charged then SGST has to be charged on the Value plus CGST
- (b) First SGST has to be charged then CGST has to be charged on the Value plus CGST
- (c) Both SGST and CGST has to be charged on same transaction value
- (d) None of the above

Ans. (c) Both SGST and CGST has to be charged on same transaction value

Q 21. While calculating the tax on an interstate supply valued at ₹ 1000

- (a) IGST has to be charged on the value of supply by the originating state whereas SGST and CGST will be charged on the value plus IGST by the destination state.
- (b) Only IGST will be charged
- (c) IGST, SGST and CGST has to be charged on same transaction value one after the other
- (d) None of the above

Ans. (b) Only IGST will be charged

Q 22. Value to be mentioned in the invoice,

- (a) Can be Inclusive of taxes provided the recipient does not want to avail Input Tax Credit
- (b) Cannot be inclusive of taxes because the tax collected has to be shown separately in the invoice
- (c) Whether tax has to be shown separately or not depends upon the provision of the SGST law of the respective State
- (d) None of the above

Ans. (b) Cannot be inclusive of taxes because the tax collected has to be shown separately in the invoice

Q 23. For supply of services, invoice should be prepared in,

- (a) Original + 1 copy
- (b) Original + 2 copy
- (c) Original + 3 copy
- (d) None of the above

Ans. (a) Original + 1 copy

Q 24. For supply of Goods, invoice should be prepared in,

- (a) Original + 1 copy
- (b) Original + 2 copy
- (c) Original + 3 copy
- (d) None of the above

Ans. (b) Original + 2 copy

Q 25. Invoice reference number is

- (a) The invoice number as printed on the invoice
- (b) Generated from the portal of GSTN
- (c) Both a and b
- (d) None of the above

Ans. (b) Generated from the portal of GSTN

Q 26. Invoice reference number is valid for

- (a) 45 days
- (b) 1 month
- (c) 30 days
- (d) None of the above

Ans. (c) 30 days

Chapter VII

Returns

FAQ

(Note – Return Rules referred was issued under Model GST Law and may be revised in near future)

Q 1. What are the various returns prescribed under the Revised Model GST Law?

Ans. The various returns prescribed under Revised Model GST Law read with GST Returns Rules are as follows:-

Return	Particulars	Due date
GSTR-1	Furnishing details outward supplies	10 th of succeeding tax period
GSTR-1A (auto-drafted)	Communication to supplier of goods and services for any addition/deletion/modification made by the recipient in GSTR-2	Accept or reject before 17 th of the succeeding tax period
GSTR-2	Furnishing details of inward supplies	Before 15 th of succeeding tax period
GSTR-2A (auto-drafted)	Part A: Communication to receiver of goods and services in respect of goods and services procured by it and uploaded by the supplier. Part B: Communication to the receiver of credit in case of distribution of credit by Input Service Distributor in Form GSTR-6 Part C: Communication of details of tax deducted at source from the payments to the receiver based on Form GSTR-7 of the deductor. Part D: Communication of details of tax collected at source on payments received by the supplier from the e-commerce operator, based on Form GSTR-8	
GSTR-3	Monthly return after finalization of outward supplies and inward supplies	20 th of succeeding tax period
GSTR-3A	Notice sent to registered taxable persons	

Return	Particulars	Due date
	when a particular return is not filed for a tax period	
GSTR-4	Return to be furnished by a registered taxable person under composition scheme	18 th of the month succeeding the quarter
GSTR-4A	Communication to the person registered under composition scheme in respect of inward supplies procured by it and uploaded by the supplier	
GSTR-5	Return to be furnished by non-resident taxable person	20 th of succeeding tax period
GSTR-6	Return to be furnished by Input Service Distributor	13 th of succeeding tax period
GSTR-6A	Communication to Input Service Distributor in respect of inward supplies procured by it and uploaded by the supplier	
GSTR-7	Return to be furnished by persons liable to deduct tax at source under Section 46 of the GST Act	10 th of succeeding tax period
GSTR-7A	Certificate to be issued to the recipient by the person deducting tax at source	Within 5 days of remitting the amount deducted
GSTR-8	Return to be furnished by persons liable to collect tax at source under Section 56 of the GST Act	10 th of succeeding tax period
GSTR-9	Annual return	31 st December of subsequent year
GSTR-9A	Annual return for composition dealers	31 st December of subsequent year
GSTR-9B	Reconciliation statement to be submitted along with Annual Return	31 st December of subsequent year
GSTR-10	Final Return	3 months from the date of cancellation/order of cancellation, whichever later

Q 2. Who is required to furnish the details of outward taxable supply? In what format should such details be furnished? What is the due date for furnishing such details?

Ans. All registered taxable persons are required to furnish the details of outward supplies of goods and services effected during the tax period, except:

- (a) Input Service Distributors
- (b) Composition suppliers
- (c) Non-resident taxable persons
- (d) Persons liable to deduct tax at source as per Section 46
- (e) Persons liable to collect tax at source as per Section 56
- (f) The details should be furnished electronically in the format prescribed in Form GSTR-1. Such returns should be furnished on or before 10th of the succeeding tax period.

Q 3. What are the details to be submitted while furnishing the details of outward supply in GSTR-1?

Ans. The supplier has to furnish the details of invoices, debit notes, credit notes and revised invoices issued in relation to outward supplies made during the tax period. Key points to be disclosed are as follows:-

- Supplies made to registered persons and unregistered persons including consumers.
- Inter-State supplies to a consumer (non-registered person) where invoice value is more than ₹ 2,50,000 should be separately captured.
- Exempted supplies, Nil-rated supplies, Exports (including deemed exports) and non-GST supplies should each be captured, separately.
- Tax liability arising in the current tax period where invoice is not issued in the current tax period (i.e., yet to be raised).
- Invoices issued in the current tax period for which tax was already paid earlier (advances).
- Supplies made through e-commerce portal of other companies to registered taxable persons and other consumers, separately.
- The supplier has to mention the Harmonized System of Nomenclature for goods and Service Accounting Code.

Q 4. Whether the details uploaded by the supplier in GSTR-1 would be communicated to the receiver?

Ans. The details uploaded by the suppliers in GSTR-1 would be communicated to the recipient in Part A of Form GSTR-2A, which is an auto-drafted form.

Q 5. What is the procedure to be followed if the recipient finds that the details disclosed in Form GSTR-2A are incorrect?

Ans. The recipient can verify and validate/modify/delete such details and even add details, and thereafter submit the same in Form GSTR-2 before 15th of the succeeding tax period.

Q 6. What happens when the recipient modifies/deletes the details appearing in GSTR-2A?

Ans. If the recipient modifies/deletes any details, such modification/deletion will be communicated to the supplier in Form GSTR-1A. The supplier can accept/reject such modification/deletion before 17th of the succeeding tax period. To the extent of such modifications/ deletions, Form GSTR-1 of the supplier would stand amended.

Q 7. On verification of GSTR-2A, if the recipient finds that certain inward supplies made by him are not reflected, can he add the details of such inward supplies manually

Ans. If the recipient finds that certain inward supplies made to him in the tax period are not reflected in the Form GSTR-2A, the recipient can manually add the details of such supplies in Form GSTR-2. Such additions will be communicated to the supplier in Form GSTR-1A. The supplier can accept/reject such modifications before 17th of the succeeding period, upon which, Form GSTR-1 filed by him would stand amended.

Q 8. After filing of Form GSTR-1, the recipient has modified/deleted/added the details. What is the procedure to be followed by the supplier?

Ans. Where the recipient has modified/deleted/added any details in his Form GSTR-2, the supplier will receive a communication in Form GSTR-1A. The supplier can accept or reject such modifications/deletions/addition before 17th of the succeeding period. If the supplier accepts the modifications/deletions/addition, the details furnished by him in Form GSTR-1 will be amended automatically.

Q 9. Whether the details furnished under GSTR-1 and GSTR-2 can be rectified? Is there any time limit for revision / rectification of such details?

Ans. The details furnished in Forms GSTR-1 and GSTR-2 which have remained unmatched as per Section 37 or 38 can be rectified as and when the error or omission is discovered. However, no rectification is permissible after filing the annual return or the return for the month of September of the following year (whichever is earlier). It may also be noted that there is no concept of revision of a filed return under the GST regime.

Q 10. Who is required to furnish the details of inward taxable supply? In what format should such details be furnished? What is the due date for furnishing such details?

Ans. All registered taxable persons are required to furnish the details of inward supplies of goods and services effected during the tax period, except:

- (a) Input Service Distributors
- (b) Composition suppliers
- (c) Non-resident taxable persons
- (d) Persons liable to deduct tax at source as per Section 46
- (e) Persons liable to collect tax at source as per Section 56

The details should be furnished electronically in the format prescribed in Form GSTR-2. Such returns should be furnished after 10th but before 15th of the succeeding tax period.

Q 11. What are the details to be submitted while furnishing the details of inward supply in Form GSTR-2?

Ans. The details regarding inward supplies will be auto-populated from GSTR-2A. However, the recipient can modify/delete/add details of inward supply. Key points to be disclosed are as follow:

- Details of inward supplies from registered taxable persons.
- Details of debit notes/ credit notes issued by the suppliers to the person.
- Details of inward supplies attracting reverse charge.
- Details of goods, capital goods and services procured from outside India. Further, the details of total eligible input tax credit and input tax credit available in the current tax period shall also be disclosed.
- Supplies received from composition taxable person, unregistered persons and other exempt/nil/non-GST supplies shall be reported separately.
- Input tax credit received from ISD, TDS credit and TCS credit.
- Input tax credit received on an invoice on which partial credit was claimed earlier.
- Where there is liability to pay tax under reverse charge mechanism even though the invoice has not been received.
- Where tax has already been paid under reverse charge mechanism in the earlier period but invoice has been received in the current tax period.
- Input tax credit reversed along with the reason for such reversal.

Q 12. What is Form GSTR-2A?

Ans. Form GSTR-2A is an auto-drafted form and contains [changes made by recipient in GSTR-1A] the details of inward supplies made by the assessee, the details of which have been uploaded by the supplier. It also contains the input tax credit distributed by the Input Service Distributor, tax deducted at source under Section 46 and tax

collected at source under Section 56. It is similar to the statement provided in Form 26AS issued under Income Tax Act, 1961. The details in GSTR-2A are auto populated.

Q 13. Supplier raises an invoice on 30.08.2017 and discloses the same in GSTR-1 for August 2017. Recipient receives the goods and records the inward supply in his books of account on 01.09.2017. How will the inward supply of the recipient and outward supply of the supplier match?

Ans. As per Section 37, details of inward supply of the recipient should match with the outward supply declared by the supplier for the current tax period or for the earlier tax period. In this case, the inward supply of the recipient is filed for the period September 2017 and will match with the outward supply of the supplier filed for the period August 2017.

Q 14. How should the assessee disclose the details of inward supplies on which he wishes to avail input tax credit?

Ans. In Form GSTR-2, against each inward supply, an option for eligibility of input tax credit is available. The assessee can select the option if he is eligible for input tax credit.

Q 15. After finalization of outward supplies and inward supplies, what is the next procedure?

Ans. After finalizing the statements for outward and inward supplies, a registered taxable person has to file the monthly return in Form GSTR-3. However, the following persons are not required to file the GSTR-3 return:-

- (a) Registered taxable person paying taxes under Composition scheme (Form GSTR-4 shall be furnished instead)
- (b) Input service distributor (Form GSTR-6 shall be furnished instead)
- (c) Non-resident taxable person (Form GSTR-5 shall be furnished instead)
- (d) Person liable to deduct tax at source as per Section 46 (Form GSTR-7 shall be furnished instead, for the purpose of reporting the taxes deducted at source)
- (e) Person liable to deduct tax at source as per Section 56 (Form GSTR-8 shall be furnished instead, for the purpose of reporting the taxes collected at source)
- (f) furnished instead, for the purpose of reporting the taxes collected at source)

The return in GSTR-3 is auto populated from Forms GSTR-1 and GSTR-2. Further, the details of tax, interest and penalty paid have to be reported in Part B of Form GSTR-3. The return has to be filed by 20th of the succeeding tax period.

Q 16 Whether an assessee under composition scheme is required to furnish details of inward supply and outward supply?

Ans. No. An assessee under the composition scheme is not required to furnish details of inward and outward supplies. Such assesses are required to file quarterly returns in Form GSTR-4 within 18 days from the end of quarter.

Q 17. What is GSTR-4A?

Ans. Form GSTR-4A contains the details of inward supplies received by composition suppliers from registered taxable persons, debit/credit notes received and tax deducted at source. This statement is auto populated from Forms GSTR-1 (filed by persons paying tax under the normal provisions), GSTR-5 and GSTR-7 filed by other assesses.

Q 18. I am a non-resident taxable assessee. What are the returns to be furnished by me?

Ans. A non-resident taxable assessee is liable to file Form GSTR-5 for furnishing the monthly details of inward and outward supplies, debit/credit notes, tax paid details, details of closing stock and refund claimed, if any. The return should be furnished by 20th of the month succeeding the tax period, or within 7 days from the last day of the validity of registration.

Q 19. Whether Input Service Distributor is liable to furnish details of inward and outward supplies?

Ans. Input Service Distributor is not liable to furnish the details of inward and outward supplies. Input Service Distributor is liable to file return in GSTR-6 on or before 13th of the month succeeding the tax period. The details relating to input tax credit distributed is communicated to the recipient in Part B of GSTR-2A.

Q 20. What is GSTR-6A?

Ans. Form GSTR-6A contains the details of inward supplies received by Input Service Distributors from registered taxable persons and debit/credit notes received. This statement is auto populated from GSTR-1 and GSTR-5 filed by other assesses bearing the same PAN as the Input Service Distributor.

Q 21. I am notified under Section 46 of the GST Act to deduct tax at source. What are the returns to be furnished by me?

Ans. Any person liable to deduct tax at source under Section 46 of the GST Act is specifically liable to furnish returns in Form GSTR-7. The details in respect of tax deducted at source, as well as the details relating to tax payable and tax paid shall be disclosed. This apart, the person shall be required to furnish other returns in Forms GSTR-1, GSTR-2 and GSTR-3, to the extent not covered in Form GSTR-7.

Q 22. I am notified under section 56 of the GST Act to collect tax at source. What are the returns to be furnished by me?

Ans. Any person liable to collect tax at source under section 56 of the GST Act is specifically liable to furnish returns in Form GSTR-8. The details in respect of tax collected at source, as well as the details relating to tax collected and tax paid shall be

disclosed. This apart, the person shall be required to furnish other returns in Forms GSTR-1, GSTR-2 and GSTR-3, to the extent not covered in Form GSTR-8 above.

Q 23. Whether returns have to be filed if the assessee has not effected any inward or outward supply during a tax period?

Ans. Section 34(8) specifies that the periodical return in Form GSTR-3 or GSTR-4 (as the case may be) shall be furnished whether or not any supplies have been effected during the tax period. Here, it is relevant to note that the term “supplies” includes both inward and outward supplies.

However, a non-resident taxable person, an input service distributor, a person liable to deduct tax at source and person liable to collect tax at source would not be liable to furnish returns (in Forms GSTR-5, GSTR-6, GSTR-7 and GSTR-8, respectively) if they have not effected any supplies requiring them to furnish the respective forms (as mentioned above).

Q 24. Whether the details furnished under GSTR-3, GSTR-4, GSTR-5, GSTR-6, GSTR-7 and GSTR-8 can be rectified?

Ans. As per section 34(9) of the Revised GST Law, if the assessee discovers any omission or incorrect particulars in Forms GSTR-3 or GSTR-4 or GSTR-6, the assessee can rectify such omission or incorrect particulars in a subsequent return, which is to be furnished for the tax period during which such omission or incorrect particulars are noticed. The entry would appear in the table showing amendment of particulars reported in earlier returns. However, no such rectification shall be permitted after filing the annual return or the return for the month of September of the following year whichever is earlier).

It may be noted that there is no provision for rectification of return filed by non-resident taxable person (GSTR-5), person liable to deduct tax at source (GSTR-7) and person liable to collect tax at source (GSTR-8).

For example - In the month of August 2018, the assessee notices that the particulars furnished in Form GSTR-3 for the month of July 2017 are incorrect. While filing the GSTR-3 for the period August 2018, the assessee can make an entry in the table showing amendment to details of earlier tax periods and thereby rectify the details entered earlier in the return for July 2017, provided, the annual return.

Q 25. During the course of inspection/audit/scrutiny/enforcement activity, the department has pointed out certain omissions or incorrect particulars in the returns. Whether the assessee can rectify the returns to correct the omissions or incorrect particulars in its returns?

Ans. As per Section 34(9), where the omission / incorrect particulars are pointed out by the department during audit/inspection/scrutiny/enforcement, the assessee cannot rectify such omissions/incorrect particulars in the returns. However, due tax and interest shall be payable thereon.

Q 26. Whether the tax payable under GST Act has to be paid to the Central Government or the State Government?

Ans. As per section 34(7), the tax payable in cash has to be paid to the 'appropriate Government' on or before the due date for filing the return. 'Appropriate Government' has been defined in Section 2(11) to mean the Central Government in respect of IGST and CGST and the State Government in respect of SGST.

Q 27. I was liable to get registered from April 12, 2017. I got my registration only on August 16, 2017. How should I disclose the details of supplies effected during the period April 12, 2017 to August 16, 2017?

Ans. As per Section 35, a registered taxable person is required to file First Return to disclose the details of supplies effected during the period between the date on which he became liable to registration till the date on which registration is granted. Therefore, the assessee has to file First Return to disclose the supplies effected during the period April 12, 2017 to August 16, 2017.

Q 28. What is meant by provisional input tax credit?

Ans. The input tax credit availed by the recipient in its return is allowed to the recipient on a provisional basis. Once the input tax credit availed by the recipient is matched with the corresponding details of outward supply furnished by the supplier or with the additional duty of customs paid by the recipient in respect of imported goods, the input tax credit will become final.

Q 29. What is meant by self-assessment?

Ans. Under the GST regime, the responsibility to compute the correct output tax liability, eligible input tax credit and output tax liability lies with the assessee. The assessee must determine the rate of tax, value of supply and the output tax payable. The assessee must also decide the eligibility of input tax credit in respect of the various inward supplies. The determination of turnover, rate of tax, value of supply, eligibility to input tax credit, reversal of input tax credit, etc. done by the assessee himself is called as self-assessment. Based on such self-assessment, the assessee has to file the various returns.

Q 30. What is meant by matching of input tax credit?

Ans. As per Section 37(1), the details of inward supplies and input tax credit availed by the recipient and disclosed in Form GSTR-2 have to be matched with the following: -

- (a) Corresponding details of outward supply furnished by the supplier in his valid return for the same tax period or earlier tax period,
- (b) Additional duty of customs paid under section 3 of the Customs Act in respect of imported goods, and

Further, duplication of claims of input tax credit would also be noted.

This apart, the details of the GSTIN of the supplier, GSTIN of the recipient, invoice/debit note number, taxable value and the tax amount shall also be matched.

Q 31. When will the input tax credit be finally accepted?

Ans. Once the details of inward supply and input tax credit are matched with the corresponding details of outward supply furnished by the supplier in his valid return for the same tax period (or earlier tax periods), or with the additional duty of customs paid by the person himself, the input tax credit shall be finally accepted. Once the input tax credit is finally accepted, the details of such acceptance will be communicated to the assessee in GST ITC-1.

Q 32. The recipient has inadvertently claimed input tax credit twice on the same invoice. What are the consequences of such duplicate claims?

Ans. Section 37(4) of the Revised GST Law provides that duplicate claims of input tax credit will be communicated to the recipient in GST ITC-1. Such duplicate claim of input tax credit will be added to the output tax payable for the month in which such GST ITC-1 is communicated to the recipient, and interest shall be payable thereon.

Q 33. If the input tax credit availed in respect of certain supplies does not match with the details uploaded by the supplier, what is the procedure to be followed?

Ans. If the input tax credit claimed by the recipient is in excess of the output tax declared by the supplier for the same supply or where the supplier does not declare such outward supply in the returns, the discrepancy will be communicated to the supplier as well as the recipient in GST ITC-1 on or before the last day of the month in which such matching is carried out. On receipt of such communication, either the supplier or the recipient can rectify the details so as to match the claim of input tax credit. Where the supplier rectifies the mistake, the amount claimed as credit shall be allowed, and the supplier shall be liable to pay due tax and interest thereon. However, where the supplier does not accept the excess input tax credit claimed by the recipient, such excess shall be added to the output tax liability of the recipient in the following month, and interest shall be payable on such amount by the recipient.

Q 34. The mismatch in input tax credit is due to the incorrect details entered by the recipient of the supplies. What is the procedure to be followed by the recipient?

Ans. If there is a mismatch in the claim of input tax credit, a communication in GST ITC-1 will be sent to both the supplier as well as the recipient of such supply. If the discrepancy is due to the incorrect particulars entered by the recipient, then the recipient can rectify such discrepancy in its return for the month in which GST ITC-1 is communicated to him. Once the discrepancy is rectified and the input tax credit is matched, a communication in GST ITC-1 will be sent to the recipient and the claim of

input tax credit will be finally accepted. However, if the recipient does not rectify the discrepancy in the month in which such discrepancy is communicated, the amount of tax payable on account of such discrepancy will be added to the output tax liability of the recipient for the month succeeding the month in which GST ITC-1 is communicated to the recipient.

Q 35. The mismatch in input tax credit is due to the incorrect details entered by the supplier. What is the procedure to be followed by the recipient?

Ans. If the supplier declares incorrect details in its GSTR-1 or does not declare a particular supply in GSTR-1, the recipient has an option of modifying/deleting/adding such details in GSTR-2. Once the recipient modifies/deletes/adds such details in its GSTR-2, the supplier will be intimated of such modification/deletion/addition in GSTR-1A. The supplier has the option to accept or reject such modification/deletion/addition. If the supplier accepts such modification/deletion/addition, his GSTR-1 is also amended accordingly and the issue of mismatch of credit does not arise. However, if the supplier rejects such modification/deletion/addition, then there will be a mismatch in the claim of input tax credit availed by the recipient. Such mismatch in input tax credit will be communicated to the supplier as well as the recipient in GST ITC-1 on or before the last day of the month in which such matching is carried out. On receipt of such communication, either the supplier or the recipient can rectify the details so as to match the claim of input tax credit. If the supplier/recipient does not correct the discrepancy, the tax payable on account of such mismatch will be added to the output tax liability of the recipient in the month succeeding the month in which GST ITC-1 is communicated to the recipient.

Q 36. Whether the recipient is liable to pay interest on the differential tax liability arising due to the mismatch of input tax credit or due to duplicate claim of input tax credit?

Ans. Yes, as per section 37(8) of the Revised GST Law, the recipient is liable to pay interest on the differential tax liability arising on account of mismatch of input tax credit or due to duplicate claim of input tax credit at the rate specified in section 45(1). The interest is liable to be paid from the date on which credit is availed till the date on which such differential tax liability is added to the output tax liability of the recipient.

Q 37. On a perusal of the provisions relating to mismatch of input tax credit, it is noticed that the tax payable on account of mismatch of input tax credit is added to the output tax liability of the recipient. Why is the recipient penalised for such mismatch?

Ans. As per section 145 of the Revised GST Law, if any person claims input tax credit, then the burden of proving such claim is on him. Therefore, if the supplier does not declare the supplies or declares output tax lower than the amount claimed as credit, the recipient is burdened with the differential tax liability.

Q 38. The discrepancy communicated in GST ITC-1 to the supplier has been rectified in subsequent return filed by the supplier. Should the recipient avail the credit once the supplier rectifies the return?

Ans. The input tax credit which remains unmatched is added to the output tax liability of the recipient in the month succeeding the month in which GST ITC-1 is communicated to the recipient. However, if the supplier rectifies the discrepancy till the due date for furnishing of return for the month of September or second quarter, as the case may be, following the end of the financial year, or the actual date of furnishing of relevant annual return, whichever is earlier, then the recipient is eligible to reduce the output tax liability to the extent of differential tax liability paid on account of such input tax mismatch.

Q 39. Once the input tax credit mismatch has been rectified, whether the recipient of supply is eligible for refund of the interest paid on the differential tax paid due to input tax credit mismatch?

Ans. As per section 37(9), once the supplier rectifies the discrepancy in the input tax credit mismatch and such rectification is accepted, then the recipient is eligible to refund of interest paid earlier. The maximum interest refundable is equivalent to the interest paid by the recipient. The recipient has to make a claim for such refund in GSTR-3. The interest to be refundable will be credited to the electronic cash ledger in Form GST PMT-3 and will be available for any future payment of interest. Alternatively, the recipient can claim the refund of such amount by following the procedure set out in section 48 of the GST Act.

Q 40. Illustration for ITC mismatch –

Ans.

- Goods supplied by A to B in the month of April 2017
- Value of goods = ₹ 1,000/-
- GST = ₹ 200/-
- A does not declare the details of such supplies in GSTR-1.
- B claims input tax deduction of ₹ 200 by adding the details of such supply in GSTR-2.
- A rejects the communication in GSTR-1A.
- The department issues GST ITC-1 to the supplier as well as recipient in the month of May 2017.
- The supplier does not rectify the discrepancy by May 2017
- The department adds ₹200 to the output tax liability of B for the month of June 2017.

- B is liable to pay ₹ 200 along with interest for the period April 2017 to June 2017.
- A rectifies the discrepancy in the month of December 2017.
- B can reduce output tax liability for January 2017 by ₹200. B will also be eligible for refund of interest paid earlier.

Q 41. Whether the credit note issued by the supplier also has to be matched?

Ans. As per Section 38, the details of credit notes issued by the supplier in respect of outward supply and claimed as reduction in output tax liability has to be matched with a corresponding reduction of input tax by the recipient of the supply. Further, the credit note issued shall also be matched for duplication of reduction of output tax liability.

Q 42. The assessee has inadvertently reduced its output tax liability twice on the same credit note. What are the consequences of such duplicate claims?

Ans. As per Section 38(1) of the GST Act, all claims of reduction in output tax liability on account of credit notes will be matched so as to ensure that the supplier does not claim such deduction more than once for a particular credit note. Where the supplier claims such deduction more than once, such discrepancy will be communicated to the supplier in GST ITC-1. Such duplicate claim of reduction of output tax liability will be added to the output tax payable of the supplier for the month in which such GST ITC-1 is communicated to the supplier.

Q 43. Deduction of output tax liability claimed on account of credit notes issued does not match with the corresponding reduction of input tax by the recipient? What is the procedure to be followed?

Ans. If the reduction in output tax liability claimed by the supplier does not match with the corresponding reduction of input tax by the recipient, then such discrepancy will be communicated to the supplier as well as the recipient in GST ITC-1 on or before the last day of the month in which such matching is carried out. On receipt of such communication, either the supplier or the recipient can rectify the details so as to match the claim of reduction in output tax liability and corresponding reduction of input tax credit.

Q 44. The mismatch in reduction in output tax liability is due to the incorrect details entered by the recipient of the supplies. What is the procedure to be followed by the supplier?

Ans. If there is a mismatch in the claim of reduction of output tax liability, a communication in GST ITC-1 will be sent to both the supplier as well as the recipient of such supply. If the discrepancy is due to the incorrect particulars entered by the recipient, then the recipient can rectify such discrepancy in its return for the month in which GST ITC-1 is communicated to him. Once the discrepancy is rectified and the reduction in output

liability is matched, a communication in GST ITC-1 will be sent to the supplier and the claim of reduction in output tax liability will be finally accepted. However, if the recipient does not rectify the discrepancy in the month in which such discrepancy is communicated, the amount of tax payable on account of such discrepancy will be added to the output tax liability of the supplier for the month succeeding the month in which GST ITC-1 is communicated to the recipient.

Q 45. Whether the supplier is liable to pay interest on the differential tax liability arising due to the mismatch of reduction in output tax liability or due to duplicate claim of reduction of output tax liability?

Ans. As per Section 38(8) of the GST Act, the supplier is liable to pay interest on the differential tax liability arising on account of mismatch of reduction in output tax liability or due to duplicate claim of reduction in output tax liability at the rate specified in Section 45(1) of the GST Act. The interest is liable to be paid from the date on which reduction in output tax liability is claimed till the date on which such differential tax liability is added to the output tax liability of the supplier.

Q 46. The discrepancy communicated in GST ITC-1 to the supplier has been rectified in subsequent return filed by the recipient. Can the supplier avail the reduction in output tax liability after the recipient rectifies the return?

Ans. The reduction in output tax liability which remains unmatched is added to the output tax liability of the supplier in the month succeeding the month in which GST ITC-1 is communicated. However, if the discrepancy is rectified within the date for filing the return for the period of September of the succeeding financial year or before the annual return is submitted by him, then the supplier is eligible to reduce the output tax liability to the extent of differential tax liability paid on account of such mismatch.

Q 47. Once the reduction in output tax liability mismatch has been rectified, whether the supplier is eligible for refund of the interest paid on the differential tax paid due to such mismatch?

Ans. As per Section 38(9), once the discrepancy in the reduction of output tax liability is rectified and such rectification is accepted, then the supplier is eligible to refund of interest paid earlier. The maximum interest refundable is equivalent to the interest paid by the recipient. The supplier has to make a claim for such refund in GSTR-3. The interest to be refundable will be credited to the electronic cash ledger in Form GST PMT-3 and will be available for any future payment of interest. Alternatively, the supplier can claim the refund of such amount by following the procedure set out in Section 48 of the GST Act.

Q 48. Who is required to file an Annual Return? In what format such return should be furnished? What is the due date for furnishing such return?

Ans. All registered taxable persons are required to furnish an Annual Return for a financial year, electronically, in Form GSTR-9. A registered taxable person paying opting to pay tax under the composition scheme is required to file the annual return in Form GSTR-9A. However, the below mentioned registered taxable persons are not required to file an Annual Return:-

- (a) Input Service Distributor
- (b) Person liable to deduct tax at source as per Section 46 (for the purpose of TDS)
- (c) Person liable to collect tax at source as per Section 56 (for the purpose of TCS)
- (d) Casual taxable person
- (e) Non-resident taxable person

Such returns should be furnished on or before 31st December of the following the end of financial year.

Q 49. Whether the Annual Return is required to be audited by Chartered Accountant / Cost Accountant?

Ans. If the turnover of the registered taxable person exceeds ₹ One crore, then the Annual Return is required to be audited by a Chartered Accountant or Cost Accountant. Further, they also have to submit reconciliation statement in Form GSTR-9B. If the turnover does not exceed ₹ One crore, the registered taxable person can himself compile the details in Form GSTR-9 and submit the return.

Q 50. Who is required to furnish Final Return?

Ans. Any registered taxable person who has applied for cancellation of registration is required to file Final return in Form GSTR-10. The return has to be filed within three months from the date of cancellation or date of order of cancellation, whichever is later.

Q 51. What are the consequences of not filing any particular return?

Ans. If the registered taxable person fails to furnish the return in Form GSTR-3 or GSTR-4 or GSTR-5 or GSTR-6 or GSTR-7 or Annual return in Form GSTR-9 or Final return in Form GSTR-10, the department will issue a notice in Form GSTR-3A asking the registered taxable person to furnish the particular return within 15 days.

Q 52. What are the consequences if the return is filed belatedly?

Ans. Where any return is filed belatedly, the registered taxable person shall be liable to pay a late fee of one hundred rupees for each day of delay subject to a maximum of five thousand rupees.

Q 53. Who is a Tax Return Preparer? Whether the Tax Return Preparer can file returns of behalf of the registered taxable persons?

Ans. Tax Return Preparer is a person who has been approved to act as a Tax Return Preparer as per Section 43 of the GST Act. He has to satisfy the conditions and eligibility as prescribed under the Rules to act as a Tax Return Preparer.

A registered taxable person can authorise a Tax Return Preparer to file the returns in Form GSTR-1, GSTR-2, GSTR-3, GSTR-4, GSTR-5, GSTR-6, GSTR-7, Annual return in GSTR-9 and Final return in GSTR-10, and also to perform other tasks as may be prescribed. In respect of returns filed by the Tax Return Preparer, the registered taxable person will be responsible for the correctness of the details furnished in the returns.

MCQ

Q 1. The details of outward supplies of goods or services shall be submitted by

- (a) 10th of the succeeding month
- (b) 18th of the succeeding month
- (c) 15th of the succeeding month
- (d) 20th of the succeeding month

Ans. (a) 10th of the succeeding month

Q 2. Details of outward supplies shall include

- (a) Invoice
- (b) Credit and Debit notes
- (c) Revised invoice issued in relation to outward supplies
- (d) All the above

Ans. (d) All the above

Q 3. The details submitted by the outward supplier in Form GSTR 1 shall be furnished to the recipient (not being a composition supplier) in Form:

- (a) GSTR 4A
- (b) GSTR 5A
- (c) GSTR 2A
- (d) GSTR 6A

Ans. (c) GSTR 2A

Q 4. The details submitted by the outward supplier in Form GSTR 1 shall be furnished to the recipient (being a composition supplier) in Form:

- (a) GSTR 4A
- (b) GSTR 5A
- (c) GSTR 2A
- (d) GSTR 6A

Ans. (a) GSTR 4A

Q 5. The details submitted by the outward supplier in Form GSTR 1 shall be furnished to the input service distributor in Form:

- (a) GSTR 4A
- (b) GSTR 5A
- (c) GSTR 2A
- (d) GSTR 6A

Ans. (d) GSTR 6A

Q 6. Which of the following is true?

- (a) The Commissioner may extend the time limit for furnishing the details of outward supplies by notification for valid reasons
- (b) The details of outward supplies shall include details of debit notes, credit notes and revised invoices issued in relation to outward supplies
- (c) The details of outward supplies shall be submitted in Form GSTR-1 by all the registered taxable persons, other than ISD, non-resident tax payer and a person paying tax under Section 9, Section 46 and Section 56
- (d) All the above

Ans. (d) All the above

Q 7. The details submitted by the supplier in Form GSTR 1 are communicated to the registered taxable person in

- (a) Form GSTR 1A on 17th of the succeeding month
- (b) Form GSTR 2A on 15th of the succeeding month
- (c) Form GSTR 2A after the due date of filing Form GSTR 1
- (d) Form GSTR 1A on 15th of the succeeding month

Ans. (c) Form GSTR 2A after the due date of filing Form GSTR 1

Q 8. Which of the following is a correct statement?

- (a) Every registered taxable person other than ISD, non-resident tax payer & a person paying tax under Section 9, 46 or 56 shall verify, validate, modify or delete the details communicated in Form GSTR 2A

- (b) The details of outward supplies communicated in Form GSTR 2A cannot be modified or altered
- (c) The registered taxable person should accept the details communicated in Form GSTR 2A by 12th of the succeeding month
- (d) The registered taxable person other than ISD, non-resident tax payer & a person paying tax under Section 9, 46 or 56 shall furnish the details of inward supplies of goods or services excluding tax payable on reverse charge basis.

Ans. (a) Every registered taxable person other than ISD, non-resident tax payer & a person paying tax under Section 9, 46 or 56 shall verify, validate, modify or delete the details communicated in Form GSTR 2A.

Q 9. The details of inward supplies of goods or services in Form GSTR 2 shall be submitted by

- (a) 10th of the succeeding month
- (b) 18th of the succeeding month
- (c) 15th of the succeeding month
- (d) 20th of the succeeding month

Ans. (c) 15th of the succeeding month

Q 10. Details of inward supplies shall include

- (a) Inward supplies of goods and services communicated in Form GSTR 2A
- (b) Inward supplies in respect of which tax is payable under reverse charge mechanism
- (c) Inward supplies of goods and services not declared by suppliers
- (d) All the above

Ans. (d) All the above

Q 11. Any modification / deletion done by the recipient to the details contained in Form GSTR 2A shall be communicated to the supplier in

- (a) Form GSTR 1A
- (b) Form GSTR 3A
- (c) Form GSTR 6A
- (d) Form GSTR 2A

Ans. (a) Form GSTR 1A

Q 12. The supplier on receiving the communication in Form GSTR 1A shall accept or reject the modified details by

- (a) 18th of the succeeding month
- (b) 20th of the month succeeding the quarter
- (c) 17th of the succeeding month
- (d) 10th of the succeeding month

Ans. (c) 17th of the succeeding month

Q 13. A registered taxable person other than ISD, non-resident tax payer & a person paying tax under Section 9, 46 or 56, shall file its periodical return in

- (a) Form GSTR 3 by 18th of the month succeeding the quarter
- (b) Form GSTR 4 by 18th of the month succeeding the quarter
- (c) Form GSTR 4 by 18th of the succeeding month
- (d) Form GSTR 3 by 20th of the succeeding month

Ans. (d) Form GSTR 3 by 20th of the succeeding month

Q 14. Every tax payer paying tax under Section 9 (composition levy) shall file the return in

- (a) Form GSTR 3 by 18th of the month succeeding the quarter
- (b) Form GSTR 4 by 18th of the month succeeding the quarter
- (c) Form GSTR 4 by 18th of the succeeding month
- (d) Form GSTR 4 by 20th of the month succeeding the quarter

Ans. (b) Form GSTR 4 by 18th of the month succeeding the quarter

Q 15. Which of the following is correct?

- (a) Non-Resident taxable person shall file the return by 20th of succeeding month in Form GSTR 5
- (b) Input Service Distributor shall furnish the return by 13th of the succeeding month in Form GSTR 6
- (c) The person collecting tax at source shall furnish the return by 10th of the succeeding month in Form GSTR 8
- (d) All the above

Ans. (d) All the above

Q 16. The certificate of details of tax deducted by the deductor shall be furnished to the deductee in Form

- (a) GSTR 7
- (b) GSTR 7A
- (c) GSTR 2A

(d) GSTR 1A

Ans. (b) GSTR 7A

Q 17. The person deducting tax at source shall deposit such amount within:

- (a) 18th of the succeeding month
- (b) 20th of the month succeeding the quarter
- (c) 17th of the succeeding month
- (d) 10th of the succeeding month

Ans. (d) 10th of the succeeding month

Q 18. State which is a true statement

- (a) The last date for payment of taxes to the appropriate Government is the last date on which the registered taxable person is required to furnish the return
- (b) Every person who is required to furnish return under Section 34(1) and 34(2) shall furnish return for every tax period whether or not supplies have been effected during such period.
- (c) Both (a) and (b)
- (d) None of the above

Ans. (c) Both (a) and (b)

Q 19. Forms GSTR 3, GSTR 4 and GSTR 6 filed can be rectified on the grounds of

- (a) Any omission or incorrect particulars
- (b) Omission or incorrect particulars found during audit/ scrutiny/ inspection
- (c) Any omission or incorrect particulars other than (b) above
- (d) Not applicable (such Forms cannot be rectified)

Ans. (c) Any omission or incorrect particulars other than (b) above

Q 20. The First return shall be filed by every registered taxable person for the period from

- (a) The date on which he became liable for registration till the date of grant of registration
- (b) The date of registration to the last day of that month
- (c) The date on which he became liable for registration till the last day of that month
- (d) All of the above

Ans. (a) The date on which he became liable for registration till the date of grant of registration

Q 21. The details of inward supply furnished by the registered taxable person shall be matched with the

- (a) Corresponding details of outward supply furnished by the corresponding taxable person
- (b) Additional duty of customs paid under section 3(5) of the Customs Tariff Act, 1975
- (c) For duplication of claims of input tax credit
- (d) All of the above

Ans. (d) *All of the above*

Q 22. If Input credit claimed by recipient is more than the output tax declared by the supplier or if the supplier has not declared the outward supply, then

- (a) The excess amount claimed as input is added to the output tax liability of the recipient
- (b) The discrepancy is communicated in GST ITC -1 to both the supplier and receiver
- (c) The excess amount claimed as input is added to the output tax liability of the supplier
- (d) The supplier is given an opportunity of being heard

Ans. (b) *The discrepancy is communicated in GST ITC-1 to both the supplier and receiver*

Q 23. The discrepancy pointed out in GST ITC 1 with regard to excess input tax credit claimed has not been rectified by the supplier as well as the recipient then the excess input tax credit is

- (a) Added to the output tax liability of the recipient
- (b) Added to the output tax liability of the supplier

Ans. (a) *Added to the output tax liability of the recipient*

Q 24. Every registered taxable person shall be entitled to take credit of input tax in his return and such input tax credit shall be credited to

- (a) Personal Ledger Account
- (b) Refund account
- (c) Electronic Cash Ledger
- (d) Electronic Credit Ledger

Ans. (d) *Electronic Credit Ledger*

Q 25. The details of every credit note relating to outward supplies furnished by the registered taxable person shall be matched

- (a) With corresponding reduction in claim for input tax credit by the corresponding taxable person in his valid return for the same tax period or any subsequent tax period.
- (b) For duplication of claims for reduction in the output tax liability
- (c) All of the above
- (d) None of the above

Ans. (c) *All of the above*

Q 26. If the reduction in output tax liability claimed by the supplier is more than the corresponding reduction in input tax credit declared by the recipient, or if the recipient has not reduced the input tax liability, then

- (a) The excess reduction claimed is added to the output tax liability of the recipient
- (b) The discrepancy is communicated in GST ITC -1 to both the supplier and receiver
- (c) The excess reduction claimed is added to the output tax liability of the supplier
- (d) The supplier is given an opportunity of being heard

Ans. (b) *The discrepancy is communicated in GST ITC-1 to both the supplier and receiver*

Q 27. The discrepancy pointed out in GST ITC 1 with regard to excess reduction of output tax has not been rectified the by the supplier as well as the recipient. The excess reduction of output tax is

- (a) Added to the output tax liability of the recipient
- (b) Added to the output tax liability of the supplier

Ans. (b) *Added to the output tax liability of the supplier*

Q 28. The due date for furnishing the annual return for every financial year by every registered taxable person other than ISD, non-resident tax payer, a person paying tax under Section 9, 46 or 56 and a casual taxable person is

- (a) 30th of September following the end of the financial year
- (b) 20th of October following the end of the financial year
- (c) 31st of December following the end of the financial year
- (d) 31st of May following the end of the financial year

Ans. (c) *31st of December following the end of the financial year*

Q 29. Every registered taxable person who is required to get his accounts audited under Section 53(4) shall furnish electronically

- (a) Annual return
- (b) Audited copy of annual accounts
- (c) Reconciliation statement reconciling the value of supplies declared in the return and the financial statement
- (d) All of the above

Ans. (d) All of the above

Q 30. The annual return shall be filed by the registered taxable person (other than composition suppliers) in Form

- (a) GSTR 7
- (b) GSTR 9
- (c) GSTR 9A
- (d) GSTR 10

Ans. (b) GSRT 9

Q 31. Find the correct match of annual returns to be filed:

- (a) Registered taxable person – Form GSTR 8
- (b) Input service distributor – Form GSTR 9
- (c) Non Resident taxable person – Form GSTR 9B
- (d) Compounding taxable person – Form GSTR 9A

Ans. (d) Compounding taxable person – Form GSTR 9A

Q 32. Notice to non-filers of return shall be sent in Form

- (a) GSTR 5
- (b) GSTR 3
- (c) GSTR 3A
- (d) GSTR 10

Ans. (c) GSRT 3A

Q 33. The final return shall be filed by the registered taxable person within

- (a) 3 months of the date of cancellation
- (b) 3 months of the date of order of cancellation
- (c) 1 month of the date of order of cancellation

(d) Later of (a) and (b)

Ans. (d) *Later of (a) or (b)*

Q 34. Any registered taxable person who fails to furnish the details and file the return within the due date prescribed shall be liable to

- (a) Interest at the rate of 1% per month
- (b) Late fee of ₹ 100 for every day up to ₹ 5,000
- (c) Both (a) and (b)
- (d) None of the above

Ans. (b) *Late fee of ₹ 100 for every day up to ₹ 5,000*

Q 35. Which of the following is correct?

- (a) Failure to file annual return within due date attracts a late fee of ₹ 100 per day up to 0.25% of his turnover
- (b) Failure to file annual return within due date attracts late fee of 1% of his turnover till the failure continues
- (c) Failure to file annual returns within due date attracts a late fee of ₹ 100 per day up to 1% of his turnover.
- (d) On failure to file annual return within due date the proper officer shall issue a notice of non-filing on such person

Ans. (a) *Failure to file annual return before due date attracts a late fee of ₹ 100 per day up to 0.25% of his turnover*

Q 36. A tax return preparer can undertake the following activities if authorized by the taxable person

- (a) Furnish details inward and outward supplies
- (b) Furnish monthly / quarterly return
- (c) Furnish Annual and Final return
- (d) All of the above

Ans. (d) *All of the above*

Chapter– VIII

Payment of Tax

FAQ

(Note – Payment Rules referred was issued under Model GST Law and may be revised in near future)

Payment of tax, interest, penalty and other amounts (Section 44), Interest on delayed payment of tax (Section 45) and Tax Deduction at Source (Section 46)

Q 1. What is Electronic tax liability register?

Ans. Electronic tax liability register is a register to be maintained in the common portal of GST in Form GST PMT-1 to record all liabilities of a taxable person. Part-I is for recording return related liabilities and Part-II is for recording other than return related liabilities.

Q 2. What are the possible debits' and credits' to Electronic tax liability register?

Ans. The possible debits' and credits' to Electronic tax liability register are as follows;

Debit	Credit
(i) the amount payable towards tax, interest, late fee or any other amount payable as per the return filed by the said person;	(i) Electronic credit ledger
(ii) the amount of tax, interest, penalty or any other amount payable as determined by a proper officer in pursuance of any proceeding under the Act or as ascertained by the said person;	(ii) Electronic cash ledger
(iii) the amount of tax and interest payable as a result of mismatch under section 37 or section 38 or section 56; or	(iii) Relief given by the appellate authority
(iv) any amount of interest that may accrue from time to time.	(iv) Reduction in penalty (if any)

Q 3. What is Electronic credit ledger?

Ans. Electronic credit ledger is a register to be maintained in the common portal of GST in Form GST PMT-2 to record input tax credit claimed, utilization, reversal and refund.

Q 4. What are the possible debits' and credits' to Electronic credit ledger?

Ans. The possible debits' and credits' to Electronic credit ledger are as follows;

Debit	Credit
(i) Discharge of any liability in accordance with Section 44;	(i) Input tax credit claimed;
(ii) Towards claim for refund of unutilized amount.	(ii) Reversal of amount debited earlier on account of final rejection of refund (Form GST PMT-2A).

Q 5. What is Electronic cash ledger?

Ans. Electronic cash ledger is a register to be maintained in the common portal of GST in Form GST PMT-3 to record deposit of tax, interest, penalty and other amounts, utilization thereof and refund.

Q 6. What are the possible debits' and credits' to Electronic cash ledger?

Ans. The possible debits' and credits' to Electronic cash ledger are as follows;

Debit	Credit
(i) Discharge of any liability in accordance with Section 44	(i) Payment made through challan on receipt of CIN
(ii) Towards claim for refund of any amount	(ii) Amount deducted under Section 46 and claimed in Form GSTR-2
	(iii) Amount collected under Section 56 and claimed in Form GSTR-2
	(iv) Reversal of amount debited earlier on account of final rejection of refund (Form GST PMT-2A)

Q 7. How one can deposit tax under GST?

Ans. A registered taxable person, or any other person on his behalf, shall generate a challan in FORM GST PMT-4 on the Common Portal and enter the details of the amount to be deposited by him towards tax, interest, penalty, fees or any other amount and pay the amount through the following means:

- (i) Internet banking;
- (ii) Credit/debit card after registering the same with the Common Portal through the authorized bank;

- (iii) National Electronic Fund Transfer (NEFT) or Real Time Gross Settlement (RTGS) from any bank;
- (iv) Over the Counter payment (OTC) through authorized banks for deposits up to ten thousand rupees per challan per tax period, by cash, cheque or demand draft.

Q 8. To whom the restriction of deposits up to ten thousand rupees per challan per tax period, by cash, cheque or demand draft is not applicable?

Ans. The restriction of deposits up to ten thousand rupees per challan per tax period, by cash, cheque or demand draft is not applicable to the deposit made by:

- (a) Government Departments or any other deposit to be made by persons as may be notified by the Board/Commissioner (SGST) in this behalf;
- (b) Proper officer or any other officer authorized to recover outstanding dues from any person, whether registered or not, including recovery made through attachment or sale of movable or immovable properties;
- (c) Proper officer or any other officer authorized for the amounts collected by way of cash or cheque, demand draft during any investigation or enforcement activity or any ad hoc deposit:

Q 9. What is the validity of Form GST PMT-4 generated at the common portal?

Ans. The validity of Form GST PMT-4 generated at the common portal shall be valid for a period of fifteen days.

Q 10. What are the special procedures to be followed for deposit of tax by way of NEFT or RTGS?

Ans. In order to deposit tax by way of NEFT or RTGS, the taxable person needs to generate a mandate form along with the challan and submit it to Bank for processing.

Q 11. What is the validity of mandate form generated at the common portal?

Ans. The mandate form generate at the common portal shall be valid for a period of fifteen days.

Q 12. What is Challan Identification Number (CIN) and when can it be generated?

Ans. CIN is the number generated for identification of payment made by the taxable person. It will be generated upon successful credit of the amount to the concerned government account maintained in the authorized bank.

Q 13. What to do if in case where account is debited with the amount paid under GST but CIN is not generated?

Ans. Where the bank account of the concerned taxable person, or the person making the deposit on his behalf, is debited but no Challan Identification Number (CIN) is generated, the said person may represent electronically in FORM GST PMT-6 through the Common Portal to the Bank or electronic gateway through which the deposit was initiated.

Q 14. Should the payment be made only from the account of the taxable person?

Ans. There is no restriction on the account to be used by the taxable payment for payment of tax. The payment can be made by a third party from his account using the GSTIN of the taxable person to get the amount debited to the electronic cash ledger of the taxable person.

Q 15. Where tax is paid at 11PM on 20th October 2017 and filed returns on the same day. If for any reason the amount is credited to the account of the appropriate Government on 21st October 2017, will it amount to default?

Ans. The date of credit to the account of the appropriate Government in the authorized bank shall be deemed to be the date of deposit in the electronic cash ledger. Therefore, in this case the date of payment/deposit of tax shall be 21st October 2017, which means a delay of one day in payment of tax.

Q 16. Where one can see the payment made in GST portal?

Ans. All payments will reflect in the 'electronic cash ledger' of the person. As the portal is common for CGST, SGST and IGST, all the payments will be reflected in a single electronic cash ledger. However, cross utilization may not be allowed within the ledger.

Q 17. Will the input tax credit claimed by a taxable person get added to the balance in electronic cash ledger?

Ans. No, input tax credit will appear separately in the 'electronic credit ledger' maintained in the common portal.

Q 18. What are the differences between electronic cash ledger and electronic credit ledger?

Ans.

Sl.No	Electronic cash ledger	Electronic credit ledger
1.	Can be used for payment of tax, interest, penalty and other amounts	Can be used only for payment of output tax
2.	Credit to the ledger will be through payment vide Challans	Credit to the ledger will be through input tax credit claimed as per GSTR-2 (inward return)

3.	Refund for excess balance in the cash ledger can be applied through GSTR-3 (monthly returns)	Refund for excess balance in credit ledger may be refunded only through the forms specified
----	----------------------------------------------------------------------------------------------	---------------------------------------------------------------------------------------------

Q 19. Can one use input tax credit for payment of interest/penalty?

Ans. No, as per Section 44 (4) of the CGST Act, amount available in the electronic credit ledger may be used for making any payment towards 'output tax' payable only. As per Section 2 (71) of the CGST Act. 'Output tax' in relation to a taxable person, means the CGST/SGST chargeable under this Act on taxable supply of goods and/or services made by him or by his agent and excludes tax payable by him on reverse charge basis. Therefore, input tax credit cannot be used for payment of interest/penalty.

Q 20. Can one use input tax credit for payment of tax under reverse charge basis?

Ans. No. The amount available in the electronic credit ledger may be used for making any payment towards 'output tax'. Further, the definition of output tax u/s 2 (71) specifically excludes tax payable under reverse charge basis. Therefore, input tax credit cannot be used for payment of tax under reverse charge basis.

Q 21. What is the manner/order of utilization of input tax credit?

Ans. The manner/order of utilization of input tax credit is as follows:

- The amount of IGST credit in the electronic credit ledger can be utilized in the following order;

IGST against IGST-CGST-SGST



Eg: If IGST credit available is ₹100, IGST liability is ₹50, CGST liability is ₹40 and SGST liability is ₹30. The credit will be utilized as follows:



In this case the balance of SGST may be paid using SGST credit or by cash.

CGST against CGST-IGST



SGST against SGST-IGST



SGST against CGST or CGST against SGST – Not allowed



Q 22. Is there any order in which liability of a person shall be discharged or it can be appropriated as per the convenience of the tax payer?

Ans. No, every taxable person shall discharge his tax and other dues in the following order:

- (a) self-assessed tax, and other dues related to returns of previous tax periods;
- (b) self-assessed tax, and other dues related to return of current tax period;
- (c) any other amount payable under the Act or the rules made there under including the demand determined under section 66 or 67.

Note 1: "tax dues" means the tax payable under this Act and does not include interest, fee and penalty.

Note 2: "other dues" means interest, penalty, fee or any other amount payable under the Act or the rules made thereunder

Q 23. Will the Electronic credit ledger be debited only with matched input tax credit?

Ans. No, the Electronic credit ledger be debited with matched, unmatched and also provisional input tax credit.

Q 24. Is principles of unjust enrichment applicable for payment made under GST?

Ans. Yes, every person who has paid the tax on goods and/or services under this Act shall, unless the contrary is proved by him, be deemed to have passed on the full incidence of such tax to the recipient of such goods and/or services.

- Q 25. Who will bear the commission charged by bank towards payment of taxes online?
- Ans. The commission charged by bank towards payment of taxes online shall be borne by the taxable person making such payment.
- Q 26. What is the procedure for payment of tax for a casual taxable person or non-resident taxable person who is required to pay tax in advance for obtaining registration?
- Ans. As GSTIN will not be available with the casual taxable person or non-resident taxable person require to pay tax in advance for obtaining registration, they will be provided a temporary identification number using which the person can deposit tax vide Form GST PMT-5.
- Q 27. Can one pay CGST, IGST and SGST together or should be paid separately in different challans?
- Ans. Form GST PMT-4 contains separate columns for CGST, IGST and SGST which shall deposit the amount to the respective account of the government though paid through a single challan, therefore, CGST, IGST and SGST can be paid together in a single challan.
- Q 28. What is the due date for payment of tax under GST?
- Ans. As per Section 34 (7), every registered taxable person, who is required to furnish a return shall pay to the account of the appropriate Government the tax due as per such return not later than the last date on which he is required to furnish such return. Therefore, the due date for payment of tax shall be the due date for filing of returns.
- Q 29. Should the challan be apportioned against a fixed tax period or can be used against any liability of a taxable person?
- Ans. The challan for payment of tax (Form GST PMT-4) does not collect details of the period for which the deposit of tax is made and any amount deposited through the challan is debited to the electronic credit ledger, from which the amount can be utilized against any liability.
- Q 30. Is HSN code for goods or accounting code for service relevant for payment of tax?
- Ans. The format of challan does not contain column to disclose the HSN code or the accounting code, therefore, it is not relevant for payment of tax.
- Q 31. How do we ensure that SGST is paid to the appropriate State Government?
- Ans. There is a specific column in Form GST PMT-4, wherein the Name of the state will be auto-populated/selected at the time of filling the challan to ensure that SGST is paid to the appropriate state government.
- Q 32. Should a taxable person maintain any minimum balance in the electronic cash ledger?

Ans. There are no provisions in the Revised Model GST Law or rules which prescribes maintenance of minimum balance in the electronic cash ledger.

Q 33. What are the provisions in relation to interest under GST?

Ans. Interest is applicable on delayed payment of tax at the rate to be notified calculated from the first day on which such tax was due to be paid. Interest is applicable on undue or excess claim of input tax credit as well (Section 45).

Q 34. If there is default in payment of tax and filing of returns, interest is payable on gross tax payable or net tax payable?

Ans. Gross tax payable, if there is default in payment of tax and filing of returns, input tax credit will become ineligible as per Section 16(2) (d) of the Model CGST Law. Therefore, the taxable person will not be allowed claim set-off of input tax credit for calculation of interest.

Q 35. There is no specific provision for interest under IGST Act, does this mean interest is not applicable for delay in payment of IGST?

Ans. No, provision of Section 45 of the CGST Act has been made applicable to IGST Act vide machinery provision contained in section 17 of IGST Act.

Q 36. Is payment of interest mandatory?

Ans. Interest being compensatory in nature, it is mandatory. Further, Section 45 uses the word 'shall' which also indicates that interest is mandatory.

MCQ

Payment of tax, interest, penalty and other amounts (Section 44)

Q 1. Which of these registers/ledgers are maintained online?

- (a) Tax liability register
- (b) Credit ledger
- (c) Cash ledger
- (d) All of them

Ans. (d) All of them

Q 2. Physical payment made through challan will be credited to which registers/ledgers?

- (a) Electronic Tax liability register
- (b) Electronic Credit ledger
- (c) Electronic Cash ledger
- (d) All of them

Ans. (c) Electronic Cash ledger

- Q 3. What is deemed to be the date of deposit in the electronic cash ledger?
- (a) Date on which amount gets debited in the account of the taxable person
 - (b) Date on which payment is initiated and approved by the taxable person
 - (c) Date of credit to the account of the appropriate Government
 - (d) Earliest of the above three dates

Ans. (c) Date of credit to the account of the appropriate Government

- Q 4. What gets debited to the electronic credit ledger?
- (a) Matched input tax credit
 - (b) Provisionally input tax credit
 - (c) Unmatched input tax credit
 - (d) All of them

Ans. (d) All of them

- Q 5. Balance in electronic credit ledger can be utilized against which liability?
- (a) Output tax payable
 - (b) Interest
 - (c) Penalty
 - (d) All of them

Ans. (d) Output tax payable

- Q 6. Balance in electronic credit ledger under IGST can be used against which liability?
- (a) IGST Liability only
 - (b) IGST and CGST liability
 - (c) IGST, CGST and SGST liability
 - (d) None of them

Ans. (c) IGST, CGST and SGST liability

- Q 7. Balance in electronic credit ledger under CGST can be used against which liability?
- (a) CGST Liability only
 - (b) CGST and IGST liability
 - (c) CGST, IGST and SGST liability
 - (d) None of them

Ans. (b) CGST and IGST liability

Q 8. Balance in electronic credit ledger under SGST can be used against which liability?

- (a) SGST Liability only
- (b) SGST and IGST liability
- (c) SGST, IGST and CGST liability
- (d) None of them

Ans. (b) SGST and IGST liability

Q 9. What should I do if I pay the wrong tax i.e. IGST instead of CGST/SGST or vice versa?

- (a) Remit tax again and claim refund
- (b) It will be auto-adjusted
- (c) It will be adjusted on application/request
- (d) None of the above

Ans. (a) Remit tax again and claim refund

Q10. What should I do if I pay tax under wrong GSTIN?

- (a) Pay again under right GSTIN and claim refund
- (b) Auto-adjustment
- (c) Adjustment on application/request
- (d) Raise ISD invoice and transfer

Ans. (a) Pay again under right GSTIN and claim refund

Q 11. I made an online payment of tax. Due to technical snag CIN was not generated but my bank account is debited. What should I do?

- (a) Wait for 24 hours for re-credit
- (b) Approach bank
- (c) File application with department (GST PMT-6)
- (d) File return without challan

Ans. (c) File application with department (GST PMT-6)

Q 12. What is the due date for payment of tax?

- (a) Last day of the month to which payment relates
- (b) Within 10 days of the subsequent month
- (c) Within 20 days of the subsequent month
- (d) Within 15 days of the subsequent month

Ans. (c) Within 20 days of the subsequent month

Q 13. My head office in Bangalore and 4 branches in different states, all registered under GST and one ISD registered unit in Delhi. How many electronic cash ledgers will I have?

- (a) 1
- (b) 4
- (c) 5
- (d) 6

Ans. (c)5

Q 14. What is the validity of challan in Form GST PMT-4?

- (a) 1 day
- (b) 5 days
- (c) 15 days
- (d) Perpetual validity

Ans. (c)15 days

Interest on delayed payment of tax (Section 45)

Q 15. I failed to pay tax and/or file returns on time. I should pay interest on?

- (a) Gross tax payable
- (b) Gross tax payable & input credit claimed
- (c) Net tax payable
- (d) No interest payable, if reasonable cause is shown

Ans. (a) Gross tax payable

Q 16. From which date interest is liable in case of excess input tax credit claimed?

- (a) From the late date of the month in which credit is claimed
- (b) From the due date for filing GSTR-2of the month in which credit is claimed
- (c) From the due date for filing GSTR-3 of the month in which credit is claimed
- (d) From the date of utilization of credit.

Ans. (c) From the due date for filing GSTR-3 of the month in which credit is claimed

FAQ

Tax Deduction at Source (Section 46)

Q 1. Who is a deductor?

Ans. A Department or an establishment, of the Central or State Government or Local authority or Governmental agencies or such persons or category of persons notified by the Central or State Government.

Q 2. Who is a deductee?

Ans. A supplier of taxable goods and/or services notified by the Central or State Government.

Q 3. What is the rate of tax deduction at source?

Ans. 1% of payment made or credited to the supplier of taxable goods and/or services.

Q 4. What is the threshold limit and on what value tax deduction to be made?

Ans. Total value of supply under a contract not exceeding ₹5 Lakhs. Value of supply for tax deduction shall be the Invoice value excluding tax.

Q 5. Whether part payment to deductee is liable for tax deduction at source?

Ans. Yes. Section 46(1) envisages tax deduction at the rate of 1% from the payment made or amount credited to the deductee.

Q 6. What is the time limit for deposit of tax deduction at source by the deductor?

Ans. Within 10 days after the end of the month in which such deduction is made.

Q 7. What is the time limit for furnishing certificate of tax deduction to the deductee?

Ans. Within 5 days of crediting the amount of tax deduction to the appropriate Government.

Q 8. What are the consequences for failure to furnish certificate of tax deduction to the deductee?

Ans. Deductor is liable to pay late fee of ₹100/- per day after the expiry of five-day period until the failure is rectified subject to a maximum of ₹5,000/-.

Q 9. What are the consequences for failure to remit tax deducted at source by the deductor?

Ans. Deductor is liable for interest under Section 45(1) in addition to payment of tax deducted at source.

Q 10. How can deductee utilize the tax deduction at source done by the deductor?

Ans. It will be available as credit to the deductee in electronic cash ledger subject to deductor showing the tax deduction in his return furnished under section 34(3).

Q 11. Whether refund to tax deduction at source available in case of excess or erroneous deduction?

Ans. Yes. However, refund to deductor shall not be granted if amount deducted has been credited to the electronic cash ledger of the deductee.

Q 12. What is Tax deduction at source?

Ans. Tax deduction at source ('TDS') is a mechanism wherein the recipient of goods or services will deduct out of the amount payable to the supplier, an amount at a percentage of value of supply and deposit the same to the account of the Government within the time prescribed.

Q 13. Whether, taxable person is liable to deduct TDS even if the supplier charged GST in his invoice?

Ans. Yes, the taxable person shall deduct the tax irrespective of whether GST is charged in the invoice or not.

Q 14. What is the rate of TDS?

Ans. The rate of TDS is 1% of the value of supply.

Q 15. Who is liable to deduct tax at source?

Ans. The Central Government or state Government may mandate the following person to deduct tax at source;

- (a) a department or establishment of the Central or State Government, or
- (b) Local authority, or
- (c) Governmental agencies, or
- (d) such persons or category of persons as may be notified, by the Central or a State Government on the recommendations of the Council.

Q 16. What is the threshold limit for tax deduction at source?

Ans. The threshold limit for tax deduction at source is rupees 5 Lakh. For the purpose of computation of threshold limit, contract value needs to be considered and not the invoice value or payment amount. However, for the purpose of ascertaining the threshold limit, the value of supply shall be considered as the amount excluding taxes.

Q 17. What are the compliances to be adhered to by the deductor and specify the due dates for the same?

Ans. The following are the compliances to be adhered to by the deductor and the due dates for the same:

Payment of TDS	Issue of Certificate
The deductor is liable to pay the amount deduct from the supplier to the Government within 10 of the subsequent month	The deductor is liable to issue Certificate to the deductee within 5 days from the date of payment of tax to the Government

Q 18. What will happen if the deductor fails to issue TDS Certificate within the time prescribed?

Ans. If the deductor fails to issue TDS Certificate within the time prescribed, the deductor shall be liable to pay, by way of a late fee, a sum of one hundred rupees per day from the day after the expiry of the five day period until the failure is rectified, subject to a cap of five thousand rupees.

Q 19. If the rate of GST on the supply on which TDS is applicable is 18% and TDS @ 1% is made at the time of payment, will the effective rate of tax become 19%?

Ans. No, tax deducted at source by the deductor is available to deductee as credit. Therefore, the deductee will effectively pay tax at only 18% (17% by cash/input tax credit and 1% by utilization of TDS credit).

Q 20. Is interest applicable on non-payment of TDS?

Ans. Yes, the deductor shall be liable to pay interest in accordance with the provisions of Section 45 (1) for failure to pay the amount deductee.

MCQ

Tax Deduction at Source (Section 46)

Q 1. What is the rate of TDS?

- (a) 1%
- (b) 4%
- (c) 5%
- (d) 18%

Ans. (a) 1%

Q 2. On what value TDS needs to be deducted?

- (a) Contract value
- (b) Contract value excluding tax
- (c) Invoice value including tax
- (d) Invoice value excluding tax

Ans. (d) Invoice value excluding tax

Q 3. What is the due date for payment of TDS?

- (a) Last day of the month to which payment relates
- (b) Within 10 days of the subsequent month
- (c) Within 20 days of the subsequent month
- (d) Within 15 days of the subsequent month

Ans. (b) *Within 10 days of the subsequent month*

Q 4. What is the due date for issue of TDS Certificate?

- (a) The date of payment of TDS
- (b) Within 10 days from the date of payment of TDS
- (c) Within 20 days from the date of payment of TDS
- (d) Within 05 days from the date of payment of TDS

Ans. (d) *Within 05 days from the date of payment of TDS*

Q 5. The deduction of tax by the deductor under section 46 of the Revised Model GST Law is at the rate of

- (a) 4%
- (b) 3%
- (c) 1%
- (d) None of the above

Ans. (c) *1%*

Q 6. The threshold limit beyond which deduction of tax at source should be made by the deductor under section 46 of the Revised Model GST Law is:

- (a) ₹ 5,00,000/-
- (b) ₹ 1,00,000/-
- (c) ₹ 10,00,000/-
- (d) None of the above

Ans. (a) *₹5,00,000/-*

Q 7. Value of supply for deduction of tax at source is:

- (a) Total Invoice Value
- (b) Invoice value excluding tax
- (c) Market Value
- (d) None of the above

Ans. (b) *Invoice value excluding tax*

Q 8. The amount of tax deducted by the deductor has to be paid to the credit of the appropriate Government within days after the end of the month in which such deduction is made:

- (a) 20 days
- (b) 10 days
- (c) 15 days
- (d) 6 days

Ans. (b) 10 days

Q 9. The time limit for furnishing the deduction-cum-remittance certificate by the deductor to the deductee is:

- (a) 10 days
- (b) 20 days
- (c) 5 days
- (d) 30 days

Ans. (c) 5 days

Q 10. The deductee can claim credit of the remittance made by the deductor in his,

- (a) Electronic credit Ledger
- (b) Tax Liability Ledger
- (c) Electronic Cash Ledger
- (d) None of the above

Ans. (c) Electronic Cash Ledger

Q 11. If excess or erroneous deduction has been made by the deductor and this amount is credited to the Electronic Cash Ledger of the deductee, refund can be claimed by,

- (a) Deductor
- (b) Deductee
- (c) Both Deductor and Deductee
- (d) None of the above

Ans. (d) None of the above

Chapter -IX

Transfer of Input Tax Credit

FAQ

Transfer of input tax credit (Section 47)

Q 1. In case of utilization of CGST credit against the IGST payable whether CGST collected will reduce or increase from CGST Account and transfer to IGST Account?

Ans. In case of utilization of CGST credit against the IGST payable, CGST collected will reduce from CGST Account and will be transferred to IGST Account by Central Government

Q 2. In case of utilization of SGST credit against the IGST payable whether SGST collected will reduce or increase from SGST Account and transfer to IGST Account?

Ans. In case of utilization of SGST credit against the IGST payable, SGST collected will reduce from SGST Account and will be transferred to IGST Account by State Government.

Chapter - X

Refunds

FAQ

(Note – Refund Rules referred was issued under Model GST Law and may be revised in near future)

Refund of tax (Section 48)

Q 1. Is the word refund defined in the Revised Model GST Law?

Ans. Yes, the word refund is defined in explanation to Section 48 of the Model CGST/SGST Law. As per the said definition, refund includes,

- (i) Refund of tax on goods and/or services exported out of India; or
- (ii) On inputs or input services used in the goods and/or services which are exported out of India; or
- (iii) Refund of tax on the supply of goods regarded as deemed exports; or
- (iv) Refund of unutilized input tax credit as provided under Section 48(3)

In terms of Section 48(3) of the Revised Model GST, subject to the provisions of section 48(10) thereof, a taxable person may claim refund of any unutilized input tax credit at the end of any tax period . Refund of unutilized input tax credit is allowed in case of exports including zero rated supplies or in cases where the credit has accumulated on account of rate of tax on inputs being higher than the rate of tax on output supplies. But, refund of unutilized input tax credit shall not be allowed when goods are subjected to export duty. Even, refund of input tax credit shall not be allowed if the supplier of goods or services claims refund of output tax paid under the IGST Act, 2016.

Q 2. Is there any time limit to claim refund under Section 48?

Ans. Yes, as per Section 48, refund application is to be filed before the expiry of two years from the relevant date.

Q 3. What is relevant date for calculating the two years' time limit?

Ans. The relevant date is different for each situation and the same is provided below:

Situation	Relevant date	
Refund is in respect of goods exported (or on inputs/ input services used in such goods)		
i. By sea	Date on which the ship or the aircraft in which such goods are loaded, leaves India	
ii. By Air		
iii. By land	Date on which such goods pass the frontier	
iv. By post	Date of dispatch of goods by the concerned Post Office to a place outside India	
Refund in respect of deemed exports	Date on which the return relating to such deemed exports is filed	
Refund is in respect of services exported (or on inputs/ input services used in such services)	Where supply of service completed prior to receipt of payment	Date of receipt of payment in convertible foreign exchange
	Where payment for service received in advance	Date of issue of invoice
Tax becomes refundable as a consequence of: (i) Judgment (ii) Decree (iii) Order (iv) Direction of Appellate Authority, Appellate Tribunal or any Court	Date of communication of such judgment, decree, order or direction	
Refund of unutilized input tax credit	End of the financial year in which such claim for refund arises	
Tax is paid provisionally under this Act or the rules made thereunder	Date of adjustment of tax after the final assessment thereof.	
In case of a person other than the supplier	Date of receipt of goods or services by such person	
In any other case	Date of payment of GST	

Q 4. Is there any form for claiming refund under Section 48?

Ans. Yes, any registered taxable person, except by the persons covered by notification issued under section 48(8) (f) of Revised Model GST Law, can file refund of any tax, interest, penalty, fees or any other amount paid in an application under FORM GST

RFD-1 electronically through the Common Portal either directly or from a Facilitation Centre, notified by the Board or Commissioner.

In terms of Draft Refund Rules, this application *inter alia*, is to be accompanied by a statement in Annex 1 of FORM GST RFD-1 containing the number and date of invoices received and issued during a tax period, where refund of any unutilized input tax credit is on account of rate of input tax being higher than the rate of output tax. Further, where the refund amount is ₹ 5 Lakh or more this application is to be accompanied by a Certificate in Annex 2 of FORM GST RFD-1 issued by a Chartered Accountant or a Cost Accountant to the effect that the incidence of tax and interest claimed as refund has not been passed on to any other person.

Q 5. To whom should the claim for refund be made?

Ans. The refund application is to be made before the proper officer of IGST/CGST/SGST.

Q 6. Can the refund of balance in cash or credit ledger be claimed?

Ans. Yes, as per provisions of Section 44(6), the balance of cash or credit after payment of tax, interest, penalty, fee or any other amount payment refund can be claimed as per provisions of Section 48. Once the refund is claimed, the amount of credit of CGST/SGST/ IGST (as the case may be) would be reduced to that extent.

Q 7. Can any registered taxable person claim the refund under Section 48?

Ans. No. Refund can only be claimed under specified circumstances.

Q 8. Can United Nations Organisation claim refund?

Ans. Yes. UNOs are entitled to claim refund of IGST/CGST/SGST paid on inward supplies of goods and/or services.

Q 9. Is there any time limit for claiming refund by UNOs?

Ans. Yes, the refund application is required to be made before the expiry of 6 months from the last day of the month in which such supply was received.

Q 10. Can any taxable person claim refund of any un-utilised ITC at the end of the tax period?

Ans. No, only the following taxable persons can claim refund of un-utilised ITC:

- (i) Persons undertaking exports (including other zero-rated supplies). Exception: No refund will be allowed on the goods exported out of India where such goods are subjected to export duty [second proviso to Section 48(3)];
- (ii) Credit has accumulated on account of rate of tax on inputs being higher than the rate of tax on outward supplies (other than cases of nil-rated or fully exempted supplies)

Q 11. Is there any condition to claim refund of unutilised ITC?

Ans. Yes. No refund of input tax credit shall be allowed if the supplier of goods or services claims refund of the output tax paid under the IGST Act, 2016

Q 12. Is there any document to be enclosed along with refund claim? If yes, what are the documents to be submitted?

Ans. Yes, the following documents are required to be enclosed along with the refund application:

- (i) Documentary evidence as may be prescribed, to establish that a refund is due to the applicant, and
- (ii) Documentary evidence to prove that incidence of tax and interest had not been passed on to any other person.

Q 13. Is there any exemption for submitting the documents required for claiming refund?

Ans. Yes, if the refund claimed is less than rupees five lakh, then documentary evidence for establishing that the refund is due, and that the incidence of tax/ interest has not passed, would not be required to be submitted. However, the taxable person may file a declaration based on the documentary or other evidence available with him, certifying that the incidence of such tax and interest is not passed on to any other person.

Q 14. Is there any way of obtaining a provisional sanction of refund claimed by the taxable person?

Ans. Yes, the proper officer may sanction refund of an amount up to ninety percent of the total amount of refund claimed, on a provisional basis in case of exporters. However, certain categories of persons may be notified, to whom provisional sanction of refund cannot be made.

Q 15. Is there any time limit on proper officer to pass final order after accepting the refund application?

Ans. Yes, the proper officer shall issue the order within sixty days from the date of receipt of refund application.

Q 16. Under what circumstances would refund be paid to the applicant?

Ans. On receipt of application, where the proper officer is satisfied as regards the refund application filed, he would pass an order sanctioning the refund.

In the following situations, the refund sanctioned would be paid to applicant,-

- (i) refund of tax on goods and/or services exported out of India or on inputs or input services used in the goods and/or services which are exported out of India;

- (ii) refund of unutilized input tax credit under Section 48(3)
- (iii) refund of tax paid on a supply which is not provided, either wholly or partially, and for which invoice has not been issued
- (iv) refund of tax in pursuance of Section 70
- (v) the tax and interest, if any, or any other amount paid by the applicant, if he had not passed on the incidence of such tax and interest to any other person; or
- (vi) the tax or interest borne by such other class of applicants as the Central or a State Government may, on the recommendation of the Council, by notification, specify

In all other cases, the amount sanctioned shall be credited to the Fund.

Q 17. Can amount of refund sanctioned be adjusted towards any tax payable by the taxable person?

Ans. Yes, the refund due to taxable person can be deducted towards tax, interest, penalty or any other amount which the taxable person is liable to pay but which remains unpaid under the Act or under any earlier law.

Q 18. Can refund sanctioned be withheld?

Ans. Yes, refund can be withheld until the taxable person has furnished the required return or paid the tax, interest or penalty.

Q 19. If an applicant had filed a refund application but all required documents have not been filed, can the application said to be complete?

Ans. No, Explanation to Section 48(7) provides that the term 'application' shall mean complete application containing all information as may be prescribed.

Q 20. Is there a minimum amount specified below which no refund can be claimed?

Ans. No. However, it must be noted that if the amount of refund is less than rupees 1,000/-, then no refund can be paid.

Q 21. Whether separate applications need to be filed for refund in case of export of goods and export of services?

Ans. Yes there shall be separate application and different procedure for refund of export of goods and export of services.

Refund in certain cases (Section 49)

Q 22. Is there any other case apart from those covered in Section 48, wherein refund can be claimed under GST?

Ans. Yes, as per Section 49 of Model GST Law, the Central/State Government may, on recommendation of the Council, by notification, specify any other person or class of persons who shall be entitled to claim a refund of taxes paid on the notified supplies of goods or services received by them.

Q 23. Is there any condition to be fulfilled to file refund claim under Section 49?

Ans. Yes; however, conditions would be prescribed by way of notification/ rules.

Interest on delayed refunds (Section 50)

Q 24. Would interest be paid on the amount of refund sanctioned?

Ans. Yes, interest would be paid if the refund is not sanctioned within 60 days from the receipt of refund application. Interest rate is yet to be prescribed.

Q 25. How would the interest be computed and paid?

Ans. Interest would be computed and paid for the period after expiry of 60 days till the date of actual refund of tax.

Q 26. If refund is made based on the order of appellate authority, then would interest be paid?

Ans. Yes, however the interest would be computed from the date of order, and not the date of application.

Consumer welfare fund (Section 51)

Q 27. Is there any consumer welfare fund under GST?

Ans. Yes, this would be established by the Central / State Government.

Q 28. Can refund be credited to fund?

Ans. Yes; however, the procedure is yet to be prescribed.

Q 29. Can the amount of tax sanctioned as refund be credited to fund?

Ans. Yes, an amount of tax under Section 48(5) or (6) can be credited to fund account.

Q 30. Can amount credited to fund account be invested?

Ans. Yes, such amount can be invested by the Central/ State Government or the authorised persons.

Utilisation of fund (Section 52)

Q 31. Can amount credited to fund be utilised?

Ans. Yes, the fund can be utilised by the Central/ State Government for the welfare of the consumers. In this regard, rules are yet to be prescribed.

Q 32. Whether details of amount credited /debited to fund is required to be maintained?

Ans. Yes, the Central/State Government shall maintain, or specify the authority who shall maintain the accounts in this regard.

MCQ

Q 1. The definition of refund does not include

- (a) Refund of tax on goods and/or services exported out of India
- (b) Refund of tax on inputs or input services used in the goods and/or services which are imported to India
- (c) Refund of tax on the supply of goods regarded as deemed exports
- (d) Refund of unutilized input tax credit as provided under sub-section (2) of section 48.

Ans. (b) *Refund of tax on inputs or input services used in the goods and/or services which are imported to India*

Q 2. Refund application is to be filed before the expiry of _____ from the relevant date.

- (a) Two years
- (b) One year
- (c) 180 days
- (d) 260 days

Ans. (a) *Two years*

Q 3. UNO's and special agency can claim refund of IGST/CGST/SGST paid on

- (a) Outward supply of goods and/or services
- (b) Inter-state supply of goods and/or services
- (c) Inward supply of goods and/or services
- (d) All of the above

Ans. (c) *Inward supply of goods and/or services*

- Q 4. What is the time limit for filing refund applicable by UNO's or Special Agency?
- (a) Before expiry of eight months from the last day of month in which inward supply received
 - (b) Before expiry of sixth months from the last day of month in which inward supply received
 - (c) Before expiry of three months from the last day of month in which inward supply received
 - (d) Before expiry of one months from the last day of month in which inward supply received

Ans. (b) *Before expiry of sixth months from the last day of month in which inward supply received*

- Q 5. No refund is allowed in case of
- (a) Where goods exported out of India are subjected to export duty
 - (b) Where goods exported out of India are not subjected to export duty
 - (c) both
 - (d) none of the above

Ans. (a) *Where goods exported out of India are subjected to export duty*

- Q 6. What is the relevant date for refund of deemed exports
- (a) Date on which the ship or the aircraft in which such goods are loaded, leaves India
 - (b) Date on which such goods pass the frontier
 - (c) Date on which the return relating to such deemed exports is filed
 - (d) Supply of service completed prior to receipt of payment

Ans. (b) *Date on which the return relating to such deemed exports is filed*

- Q 7. A taxable person may not claim refund of any unutilized input tax credit at the end of any tax period. This statement is True or False
- (a) True
 - (b) False
 - (c) Both a) and b) are correct
 - (d) None of the above

Ans. (b) *False*

Q 8. In case of refund claim on account of export of goods and/or services made by such category of registered taxable persons as may be notified in this behalf, what percent would be granted as refund on a provisional basis?

- (a) 70%
- (b) 65%
- (c) 80%
- (d) 90%

Ans. (d) 90%

Q 9. The applicant shall not necessary to furnish any documents or evidences if the refund amount claimed is less than

- (a) ₹ 6 lakh
- (b) ₹ 5 lakh
- (c) ₹ 10 lakh
- (d) ₹ 20 lakh

Ans. (b) ₹ 5 lakh

Q 10. Refund shall not be paid to the applicant if the refund amount is less than

- (a) ₹ 1,000
- (b) ₹ 5,000
- (c) ₹ 7,000
- (d) ₹ 10,000

Ans. (a) ₹ 1,000

Q 11. For the purpose of Sub-section (10) of section 48 Specified date for filing an appeal shall be-

- (a) 60 days from the date of filing an appeal
- (b) 30 days from the date of filing an appeal
- (c) 45 days from the date of filing an appeal
- (d) None of the above

Ans. (b) 30 days from the date of filing an appeal

Q 12. There is no condition to claim refund of unutilised ITC. True or False

- (a) False
- (b) True
- (c) Both are correct
- (d) None

Ans. (a) False

Q 13. Any registered taxable person can claim the refund under section 48?

- (a) Yes
- (b) No

Ans. (b) No.

Q 14. The sanction refund amount can be adjusted against the payments which he is liable to pay but remains unpaid under the earlier law.

- (a) Tax
- (b) Penalty
- (c) Interest and other amounts
- (d) All of the above

Ans. (d) All of the above

Q15. The time limit to proper officer to pass final order after accepting the refund application is -

- (a) Within sixty days from the date of receipt of application.
- (b) Within eighty days from the date of receipt of application.
- (c) Within ninety days from the date of receipt of application.
- (d) Within thirty days from the date of receipt of application.

Ans. (a) Within sixty days from the date of receipt of application.

Q 16. The SEZ developer or SEZ unit exporting goods and / or services shall not be eligible to claim refund of IGST paid by the registered taxable person on such supply. Is this statement true or False?

- (a) True
- (b) False
- (c) None of the above
- (d) both

Ans. (b) False

Q 17. Interest on refund amount is required to be paid after expire of From the date of receipt of the application

- (a) 60 days
- (b) 90 days
- (c) 180 days
- (d) 240 days

Ans. (a) 60 days

Chapter - XI

Accounts and Records

FAQ

Accounts and other records (Section 53)

- Q 1. Should every registered taxable person maintain books of account?
- Ans. Yes, as per Section 53 of Model GST law, every registered taxable person shall keep and maintain the true and correct account of production or manufacture of goods, of inward or outward supply of goods and/or services, of stock of goods, of input tax credit availed, of output tax payable and paid, and such other particulars as may be prescribed in this behalf.
- Q 2. Where are the books of account liable to be maintained?
- Ans. The books of account are to be maintained at principal place of business as mentioned in the certificate of registration.
- Q 3. In case of more than one place of business, the records are required to be maintained only at principal place of business?
- Ans. No, in case of additional places of business, the accounts relating to each place of business shall be kept at such places of business concerned (provided such place is specified in the certificate of registration).
- Q 4. Whether accounts can be maintained in the electronic form?
- Ans. Yes, the registered person may keep and maintain such accounts and other particulars in the electronic form, in the manner as may be prescribed.
- Q 5. Is any category of registered taxable person required to maintain additional accounts or documents?
- Ans. The Commissioner/Chief Commissioner may notify a class of taxable persons to maintain additional accounts or documents for such purpose as may be specified. Such categories of persons shall be liable to maintain such accounts/ documents.
- Q 6. Can an exception be made for maintenance of books of account as per provisions of Section 53 of the GST Act?
- Ans. Yes, in case any class of taxable persons is not in a position to keep and maintain accounts in accordance with the provisions of this section, the Commissioner/ Chief Commissioner may permit such class of taxable persons to maintain accounts in such manner as may be prescribed after recording the reasons for the same.

Q 7. Whether the accounts and records maintained by the registered taxable person needs to be audited?

Ans. Yes, every registered taxable person whose turnover during a financial year exceeds the prescribed limit of ₹ one crore, shall get his accounts audited by a chartered accountant or a cost accountant and shall submit to the proper officer a copy of the audited statement of accounts, the reconciliation statement under Section 39(2) and such other documents in the form and manner as may be prescribed in this behalf.

Q 8. Can the provisions of Sections 66 or 67 be made applicable for not maintaining books of account?

Ans. Yes, where the registered taxable person fails to account for the goods and/or services in accordance with Section 53(1), the proper officer shall determine the amount of tax payable on the goods and/or services that are not accounted for, as if such goods and/or services had been supplied by such person and in this regard, and the provisions of Sections 66 or 67, as the case may be, shall apply, mutatis mutandis, for determination of such tax.

Note: Section 66 & 67 are the demand-related provisions under the Model GST Law.

Q 9. Does the law require any unregistered persons to maintain books of account?

Ans. Yes, every owner or operator of warehouse or godown or any other place used for storage of goods (whether registered or not) shall maintain records of consigner, consignee and other relevant details of the goods as may be prescribed.

Period of retention of accounts (Section 54)

Q 10. Is there any time period during which the maintenance of accounts and records is mandatory?

Ans. Yes, as per section 54 every registered taxable person is required to keep and maintain books of account or other records as prescribed under Section 53(1) and retain them until the expiry of sixty months from the due date for filing of Annual Return for the year pertaining to such accounts and records.

Q 11. What is the time period prescribed for maintenance of accounts and records if the taxable person is a party to an appeal or revision?

Ans. A taxable person, who is a party to an appeal or revision or any other proceeding before any Appellate Authority or Tribunal or Court, whether filed by him or by the department, is required to retain the books of account and other records pertaining to the subject matter of such appeal or revision or proceeding for a period of one year after final disposal of such appeal or revision or proceeding, or until the expiry of sixty months from the last date of filing of Annual Return for the year pertaining to such accounts and records, whichever is later.

MCQ

Q 1. The books and other records U/S 53 are to be maintained at

- (a) Place where the books and accounts are maintained
- (b) Place of address of the Proprietor/ Partner/Director/Principal Officer
- (c) Principal place of business mentioned in the Certificate of Registration
- (d) Any of the above

Ans. (c) *Principal place of business mentioned in the Certificate of Registration*

Q 2. In case, more than one place of business situated within a state specified in the Registration Certificate, the books and Accounts shall be maintained at

- (a) Each place of business pertaining to such place alone
- (b) Place where the books of accounts are maintained for all places situated within a state
- (c) At principal place of business covered mentioned in the Registration Certificate for all places of business in each state
- (d) Any of the above

Ans. (a) *Each place of business pertaining to such place alone*

Q 3. Accounts are required to be maintained in

- (a) Manual form
- (b) Electronic form
- (c) Manual and electronic form
- (d) All the above

Ans. (d) *All the above*

Q 4. A non-registered but required to maintain records

- (a) Owner of warehouse
- (b) Owner of godown
- (c) Owner of any other place used for storage of goods
- (d) All the above

Ans. (d) *all the above*

Q 5. If a turnover during a financial year exceeds the prescribed limit, then accounts get audited by

- (a) Chartered Accountant
- (b) Cost Accountant
- (c) Either (a) or (b)
- (d) All of the above

Ans. (c) *Either (a) or (b)*

Q 6. What accounts and records are required to be maintained by every registered taxable person at his principal place of business

- (a) account of production or manufacture of goods
- (b) inward or outward supply of goods and/or services
- (c) stock of goods
- (d) input tax credit availed
- (e) output tax payable and paid
- (f) All of the above

Ans. (f) *All of the above*

Q 7. The time period prescribed for maintenance of accounts and records if the taxable person is a party to an appeal or revision shall be-

- (a) Two year after final disposal of such appeal or revision or proceeding, or until the expiry of thirty-six months from the last date of filing of Annual Return for the year pertaining to such accounts and records, whichever is later
- (b) Two year after final disposal of such appeal or revision or proceeding, or until the expiry of sixty months from the last date of filing of Annual Return for the year pertaining to such accounts and records, whichever is later
- (c) One year after final disposal of such appeal or revision or proceeding, or until the expiry of sixty months from the last date of filing of Annual Return for the year pertaining to such accounts and records, whichever is later
- (d) One year after final disposal of such appeal or revision or proceeding, or until the expiry of forty months from the last date of filing of Annual Return for the year pertaining to such accounts and records, whichever is later

Ans. (c) *One year after final disposal of such appeal or revision or proceeding, or until the expiry of sixty months from the last date of filing of Annual Return for the year pertaining to such accounts and records, whichever is later*

Q 8. Taxable person has to maintain his records for a period of

- (a) expiry of sixty months from the last date of filing of Annual Return for the year
- (b) expiry of forty months from the last date of filing of Annual Return for the year
- (c) expiry of thirty months from the last date of filing of Annual Return for the year
- (d) expiry of ninety months from the last date of filing of Annual Return for the year

Ans. (a) *Expiry of sixty months from the last date of filing of Annual Return for the year*

Chapter - XII

Job Work

FAQ

Job Work – Special procedure for removal of goods for certain purposes (Section 55)

Q 1. Who is principal for the purpose of job work?

Ans. A registered taxable person, who sends any inputs and or capital goods without payment of tax to a job worker for job-work and from there subsequently send to another job worker (Section 55).

Q 2. Whether goods sent by a taxable person to a Job Worker will be treated as supply and liable to GST? If yes, why?

Ans. Goods sent by a taxable person to a Job Worker will be treated as supply and liable to GST only if, the conditions specified in section 55 of the Revised Model GST Law are not met.

The deeming provision contained in section 55(3) and section 55 (4) to treat goods (the inputs and capital goods respectively) sent by the principal to job worker as supply on the day when the inputs/ capital goods were sent out to any of his place of business is applicable only when the condition of section 55(1) with respect to receiving back the inputs, after completion of job work or otherwise and/or and capital goods within the stipulated period of 1 year and 3 year respectively of their being sent, is not satisfied. However, it shall not be regarded as supply, if the conditions as specified in section 55 of Revised Model GST law are satisfied. Moreover, the above conditions does not apply to moulds and dies, jigs and fixtures, or tools sent to job worker.

Q 3. Does the additionally purchased material, by the job-worker, incorporated in the goods received from the principal amount to supply?

Ans. Yes, it amounts to supply in the hands of the job workers and taxable at regular rates.

Q 4. Can a job worker take input credit on the inputs used in the process of job work?

Ans. Yes, the job worker is eligible to claim input tax credit since the processing charges received in respect of labor charges and additional goods added are taxable in the hands of the job worker.

Q 5. Whether the Job worker is liable to pay GST under reverse charge mechanism on the goods or services if notified?

Ans. Yes. In terms of section 8(3) of the Revised Model GST Law on the specified categories of supply of goods and/or services, the recipient of such goods and/or services is liable to pay GST under reverse charge basis. Further, Section 55 of Revised Model GST Law does not provide any exemption to job worker in this regard.

Q 6. Can a registered taxable person send goods without payment of tax to his Job Worker?

Ans. Yes. Section 55(1) of the Revised Model GST Law provides that the registered taxable person (principal) can send the taxable goods to a job-worker for job-work without payment of tax. Further, he can send the goods from one job-worker to another job-worker and so on subject to certain condition. It may be noted that provisions of Section 55 are not applicable if non-taxable or exempted goods are proposed to be sent for job-work.

Q 7. Is a job-worker required to take registration?

Ans. Yes, as a Job-worker would be a supplier of services, he would be required to obtain registration if his aggregate turnover exceeds the prescribed threshold.

Q 8. Whether processing charges charged by the job worker to be shown separately in invoice and is he also required to charge GST on the same?

Ans. Yes, if the goods supplied by the principal satisfies the conditions as enumerated in section 55 of the Revised Model GST Law, then the job worker will have to show the processing charges separately and charge tax only on the processing charges.

Q 9. Whether the goods of principal directly supplied from the job-worker's premises will be included in the aggregate turnover of the Job Worker?

Ans. No. Since the responsibility of accountability of inputs and/or capital goods lies with principal, it will be included in the aggregate turnover of the principal as enumerated in section 55 of the Revised Model GST Law.

Moreover, Explanation 2 to clause 2 of Schedule V of the Revised Model GST Law clarifies that supply of goods, after completion of job-work, by a registered job worker shall be treated as the supply of goods by the "principal" referred to in section 55, and the value of such goods shall not be included in the aggregate turnover of the registered job worker.

Q 10. Can the principal supply the goods directly from the premises of the job-worker without bringing it back to his own premises?

Ans. Yes, subject to the condition that the principal should have declared the premises of such job-worker as his additional place of business or the job-worker is a registered person or where principal is engaged in supply of goods as notified by the Commissioner.

Q 11. Under what circumstances can the principal directly supply goods from the premises of Job Worker without declaring it as additional place of business?

Ans. The goods can be supplied directly from the place of business of job-worker without declaring it as additional place of business in two circumstances namely where the job-worker is a registered taxable person or where the principal is engaged in supply of goods as may be notified by the Commissioner in this behalf.

Q 12. What are the provisions relating to availment of input tax credit by the principal in respect of inputs sent to a Job Worker?

Ans. In the Revised Model GST Law, aspects relating to availment of input tax credit in respect of inputs sent for job-work have been specifically dealt with in Section 20, which provides that the principal shall be entitled to avail credit of inputs sent to a job-worker if the said inputs, after completion of job-work or otherwise are received back within a period of one year from the date of being sent to a job worker. In case the inputs are sent directly to the job-worker, the date shall be counted from the date of receipt of inputs by job-worker. Further, if such inputs are not received back within a period of one year then it shall be deemed that the inputs has been supplied by principal to the job worker on the day when the said inputs were sent out.

Q 13. What are the provisions concerning availment of input tax credit by the principal in respect of capital goods sent to a Job Worker?

Ans. In the Revised Model GST Law, aspects relating to availment of input tax credit in respect of capital goods sent for job-work have been specifically dealt in Section 20, which provides that the principal shall be entitled to avail the credit of taxes paid on capital goods if the said capital goods, other than moulds & dies, jigs & fixtures, or tools, after completion of job-work or otherwise are received back within a period of three years from the date of being sent to the job worker. In case, the capital goods are sent directly to the job-worker, the date shall be counted from the date of receipt of capital goods by job-worker. Further, if such capital goods, other than moulds & dies, jigs & fixtures, or tools, are not received back within a period of three year then it shall be deemed that such capital goods have been supplied by the principal to the job worker on the day when the said capital goods were sent out.

Q 14. If the conditions specified in section 55 in respect of receiving back the inputs within stipulated time are not satisfied what is the implications in the hands of principal?

Ans. In terms of section 55(3), if the said inputs are not received back within the stipulated time i.e., one year, then it shall be deemed that the said inputs had been supplied by the principal to the job-worker on the day when the said inputs were sent out.

Q 15. If the conditions specified in section 55 in respect of receiving back the inputs within stipulated time are not satisfied what is the implications in the hands of job worker?

Ans. In terms of section 55(3), if the said inputs are not received back within the stipulated time, then it shall be deemed that the said inputs had been supplied by the principal to the job-worker on the day when the said inputs were sent out. Accordingly, such goods will become the inputs of the job-worker and he can avail the input credit of tax on the same if the principal issue a tax invoice and the same is declared in the return of the principal in terms of section 33 and by the job worker in terms of section 34 of the Model GST law. Further the value of such goods will be included in the computation of aggregate turnover of the job-worker.

Q 16. If the conditions specified in section 55 in respect of receiving back the capital goods within stipulated time are not satisfied what is the implications in the hands of principal?

Ans. In terms of section 55(4), if the said capital goods, other than moulds & dies, jigs & fixtures, or tools, are not received back within the stipulated time i.e., 3 years, then it shall be deemed that the said capital goods had been supplied by the principal to the job-worker on the day when the said capital goods were sent out.

Q 17. Can the job worker take input credit of goods in case the goods sent to job worker is deemed as supply in terms of section 55(3)?

Ans. Yes, job-worker can take the input credit subject to section 33 of the Model GST Law. Further, such credit shall not be allowed after furnishing of return under section 34 for the month of September following the end of the financial year to which such details pertain or furnishing of the annual return, whichever is earlier.

Please note that for the above purpose the relevant date is the date on which the goods are sent to job-work by the principal and not the date on which the period for receiving back the goods from job-worker expires.

Q 18. How is the movement of goods to be made to job worker? Whether invoice is to be raised?

Ans. The principal can move the goods to a job-worker place under the cover of a deliver challan and such other documents which may be prescribed only if the goods are removed in terms of section 55 of the Revised Model GST law.

Q 19. Whether the principal is required to raise a taxable invoice in case of goods sent to job worker is deemed as supply in terms of section 55(3) and (4)?

Ans. Yes, the principal is required to raise a taxable invoice on the day immediately after the expiry of the one year or three years period of their being sent out, for inputs or capital goods the case may be.

Q 20. How the GST is to be discharged on the goods which fails to satisfy the condition of receiving back within stipulated period from job-worker?

Ans. If the principal does not receive the goods within one year or three years period for inputs or capital goods (other than moulds & dies, jigs & fixtures, or tools) as the case may be, then it will be considered as supply in terms of section 20 and 55. In such cases the principal has to declare it as an outward supply and pay the GST along with interest calculated from the date such goods are sent to job-worker.

Q 21. Can the principal avail the input credits on the goods directly sent to job worker's place?

Ans. Yes, in terms of section 20(2) of the Revised Model GST law the principal shall be eligible to take credit of input tax on inputs even if the inputs are directly sent to a job worker for job work without their being first brought to his place of business.

Q 22. Whether ITC can be taken in respect of moulds & dies, jigs & fixtures, or tools sent to a Job Worker?

Ans. Yes, as there is no time limit prescribed to receive back such goods from job worker, as Section 55(4) specifically excludes moulds & dies, jigs & fixtures, or tools.

Q 23. Can the job worker sell directly any waste and scrap generated during the job work?

Ans. Yes, in terms of section 55(5) subject to payment of tax, if job worker is registered otherwise principal has to discharge the tax liability.

Q 24. Can an unregistered person take the benefit of section 55?

Ans. No, section 55 allows only a registered taxable person to send goods without payment of duty. Therefore, principal supplying goods to job worker is compulsorily required to be registered as a taxable person

Q 25. Whether the job worker will have to be compulsorily registered?

Ans. No. Section 55 of the Revised Model GST law does not prescribe any such condition. Hence, the threshold benefit of registration is equally applicable even in case of a job worker.

MCQ

1. Should the principal referred to in Section 55 be registered?

(a) Yes

(b) No

Ans. (a) Yes

2. Which section provides tax-free movement for sending inputs and/or capital for job-worker?
- (a) 20
 - (b) 55
 - (c) 175
 - (d) 177

Ans. (b) 55

3. Who is a principal as per Section 55?
- (a) A person who sends inputs and/or capital goods for job-work
 - (b) A registered taxable person who sends inputs and/or capital goods for job-work
 - (c) A registered taxable person who supplies inputs and/or capital goods for job-work
 - (d) None of the above

Ans. (b) A registered taxable person who sends inputs and/or capital goods for job-work

4. Is Section 55 applicable to all categories of goods?

- (a) Yes
- (b) No

Ans. (b) Yes

5. When will the inputs and/or capital goods sent to job-work become a supply?

- (a) When the inputs and/or capital goods sent to job-worker are received within 1 year or 3 years respectively
- (b) When the inputs and/or capital goods sent to job-worker are supplied, with or without payment of tax, from the job-workers place within 1 year or 3 years respectively
- (c) Both under (a) or (b)
- (d) None of the above

Ans. (c) Both under (a) or (b)

6. From when will the period of one or three years be calculated under Section 55?

- (a) The day when such inputs and/or capital goods sent to job-worker
- (b) The day when the job-worker receives the said goods, in case the job-worker receives the goods directly
- (c) Option (a) and (b)
- (d) None of the above

Ans. (c) Option (a) and (b)

7. Will a principal who sends moulds, dies, jigs, tools and fixtures charge GST on such removal of these items?
- (a) No, provided the time criteria is met
 - (b) Yes, if the time criteria is not met
 - (c) No, GST does not specify any time criteria for return of such items
 - (d) Yes, as it is assumed to be supply

Ans. (c) No, GST does not specify any time criteria for return of such items

8. GST is applicable on__
- (a) Inputs and/or capital goods sent to job-worker (Satisfying conditions u/s 55)
 - (b) The job-worker charges and additional material added by the job-worker on the inputs sent by the principal
 - (c) Both of the above
 - (d) None of the above

Ans. (b) The job-worker charges and additional material added by the job-worker on the inputs sent by the principal

9. When should a job-worker take registration?
- (a) Always
 - (b) Only if his aggregate turnover exceeds the threshold limits specified under Schedule I
 - (c) Never
 - (d) None of the above

Ans. (b) Only if his aggregate turnover exceeds the threshold limits specified under Schedule I

10. Can a principal supply inputs and/or capital goods from the job-worker's premises?
- (a) Yes, only when the job-worker is registered
 - (b) Yes, even if the job-worker is unregistered by declaring the job-worker's premises as his additional place of business
 - (c) Yes, irrespective of whether the job-worker is registered or not, principal is engaged in the supply of goods which are notified by the Commissioner on this behalf
 - (d) All of the above

Ans. (d) All of the above

11. Mr. X has sent his goods to Mr. Y on job-work on 07-05-2017. Mr. X does not receive the goods back within one year. When is this deemed to be supply in the hands of Mr. X?

- (a) 06-05-2018
- (b) 07-05-2017
- (c) 03-11-2018
- (d) Not Taxable

Ans. (b) 07-05-2017

12. In the above example, should Mr. Y charge GST on sending the goods back to Mr. X after the job-work process done by him? If yes, can he take the credit of GST charged by the principal?

- (a) Yes, Yes
- (b) No, No
- (c) Yes, No
- (d) No, Yes

Ans. (a) Yes, Yes

13. In the above example, if Mr. Y charges GST on the goods sent by Mr. X shall this be treated as an outward supply of Mr. Y and be included in the aggregate supply of Mr. Y?

- (a) Yes
- (b) No

Ans. (a) Yes

14. In the above example, if Mr. X has sent some tools to Mr. Y for use during the job-work done when should the said tools be received back by Mr. X?

- (a) 06-05-2018
- (b) 06-05-2020
- (c) 03-11-2018
- (d) No time specified under Model GST Law

Ans. (d) No time specified under Model GST Law

15. In the above example, if Mr. Y sends the tools back to Mr. X, should he charge GST on returning such tools to Mr. X?

- (a) Yes
- (b) No

Ans. (b) No

16. Will the inputs and/or supplied from the job-worker's premises be considered for calculating the aggregate turnover of the job-worker?

- (a) Yes
- (b) No

Ans. (b) No

17. Which section specifies the conditions to be fulfilled for claiming ITC on inputs and/or capital goods sent to job-worker?

- (a) 20
- (b) 55
- (c) 175
- (d) 177

Ans. (a) 20

18. Can principal take input tax credit on the inputs and/or capital goods sent to job-worker?

- (a) Yes, unconditionally
- (b) No, unconditionally
- (c) Yes, if the conditions are met
- (d) No, if the conditions are not met

Ans. (c) Yes, if the conditions are met

19. If the job-worker is eligible to claim ITC on the goods received from the principal, is there a time limit within which such ITC shall be availed/claimed by the job-worker?

- (a) Within September 30 of following year
- (b) Filing the annual return for the period
- (c) Option (a) or (b), whichever is earlier
- (d) No time limit prescribed to claim such ITC

Ans. (c) Option (a) or (b), whichever is earlier

20. How can the principal move goods to the job-worker?

- (a) Job-work challan
- (b) Tax invoice

- (c) However he intends to
- (d) Option (a) or (b)

Ans. (a) Job-work challan

21. What are the consequences if the inputs and/or capital goods are not received or returned within the time limit prescribed?
- I. It shall be deemed to be a supply on the day such inputs and/or capital goods are sent to job-worker
 - II. No consequences
 - III. The principal to discharge GST along with interest
 - IV. Principal to reverse the input tax credit taken and pay interest to the government
- (a) I and III
 - (b) I and IV
 - (c) Only II
 - (d) Option (a) or (b)

Ans. (d) Option (a) or (b)

22. Who will undertake the responsibility and accountability for any contravention under this Act?
- (a) Principal
 - (b) Job-worker
 - (c) Manufacturer
 - (d) No-body

Ans. (a) Principal

23. Who should discharge the liability of GST on the scrap generated during job-work?
- (a) Job-worker, if registered
 - (b) Principal, if job-worker is not registered
 - (c) Always principal
 - (d) Option (a) or (b)

Ans. (d) Option (a) or (b)

24. If a principal has to claim credit of the inputs sent for job-work before the appointed day, he should receive such inputs within _____ from the appointed day.
- (a) 1 year

- (b) 6 months
- (c) At most 8 months, in-case of any extension
- (d) Option (b) or (c)

Ans. (c) At most 8 months, in-case of any extension

25. What are the implications if the inputs are not returned back within the prescribed time limit as answered in the above question?

- (a) ITC claimed earlier has to be reversed
- (b) ITC claimed earlier will be recovered as arrears of tax under the Act
- (c) Principal to discharge GST
- (d) No implication under GST

Ans. (b) ITC claimed earlier will be recovered as arrears of tax under the Act

CHAPTER XIII

Electronic Commerce

FAQ

Collection of tax at source (Section 56)

- Q 1. What is electronic commerce and who is an electronic commerce operator?
- Ans. As per Section 2(41) of the Revised Model GST Law, electronic commerce means supply of goods and/or services including digital products over digital or electronic network. As per section 2(42) of the Revised Model GST Law electronic commerce operator means any person who owns, operates or manages digital or electronic facility or platform for electronic commerce.
- Q 2. Can the electronic commerce operator sell goods and/or services on his own behalf?
- Ans. Yes, there are no such restrictions under the Revised Model GST Law. However, it would be treated as any other form of supply of goods and/or services and chargeable to tax accordingly. Since the goods and/or services are supplied on his own behalf, provisions of collection of tax source do not apply to such transaction.
- Q 3. What would be the rate of tax for collection of tax at source applicable to electronic commerce operator and on what value would the rate of tax be applied on?
- Ans. The rate of tax for collection of tax source prescribed in the Revised Model GST Law is 1%. The said 1% would be on the net value of taxable supplies made through the electronic commerce where the consideration with respect to such supplies is to be collected by the electronic commerce operator.
- Q 4. Does the net value of taxable supplies include all the transactions made through electronic commerce?
- Ans. No, net value does not include transactions where the GST is liable to be paid by the electronic commerce operator on services to be notified by the Government under section 8(4). Net value of taxable supplies is the aggregate value of taxable supplies of goods or services made during any month by all registered taxable persons through the operator as reduced by the aggregate value of taxable supplies returned to the suppliers during the said month.
- Q 5. Are there any deductions allowable while computing the tax collection at source?
- Ans. Yes, the taxable supplies returned to the supplier on the electronic commerce is allowed as a deduction while calculating the net value.

Q 6. Is electronic commerce operator liable to collect tax at source if he does not collect the consideration for supplies?

Ans. As per the provisions of Section 56(1), an electronic commerce operator shall collect tax at source only where the consideration in respect of supplies is to be collected by the operator. Therefore, he is not liable to collect tax in such a situation.

Q 7. Are there any powers vested with the Government to enhance the rate of tax in case of collection of tax at source in any time future?

Ans. No, section 56(1) does not vest any powers with any authority to increase/decrease the rate of tax fixed at 1%.

Q 8. Can a supplier on electronic commerce opt not to register under GST?

Ans. No. In case such supplier operates through an electronic commerce operator who is required to collect tax at source under Section 56 such supplier is required to register under GST. Also, the threshold limit specified under Schedule V shall not apply to such suppliers.

However, in case of supplier where the electronic commerce operator does not collect the consideration with respect to supplies made on electronic commerce, then in such case, such supplier will be eligible to claim the threshold benefit for registration as per Schedule V.

Q 9. What is the time at which the electronic commerce operator should collect the tax at source?

Ans. No clarity in Section 56. However, it may be construed to be, the date of receipt of consideration by the electronic commerce operator on behalf of the supplier.

Q 10. Is there any threshold limit specified for collection of tax at source?

Ans. No, there is no threshold limit specified.

Q 11. If out of the total consideration received by the operator some part is adjusted against receivable from the supplier, should tax be collected at source by the operator even on such amount which is adjusted against other amounts received from the supplier?

Ans. Yes, as per Section 56(2), irrespective if the mode of recovery of consideration by the supplier from the operator, tax should be collected at source on the net value as defined in section 56(1) of the Revised Model GST Law. There is no deduction envisaged in the Model GST law in this regard.

Q 12. Whether the rate of tax of 1% specified in section 56 is CGST or SCGST or a combination of both CGST and SGST?

Ans. Since the Revised Model GST Law published applies to both CGST and SGST, a view could be taken that 1% is applicable for separately for CGST and SGST aggregating to 2%.

Q 13. What is the time within which such TCS is to be remitted by the e-commerce operator to Government account? Is the operator required to file any returns for this purpose?

Ans. The amount collected by the e-commerce operator ('operator', in short) is to be paid to the credit of appropriate government within 10 days after the end of the month in which amount was so collected. The operator is required to file a return online giving details of all amounts collected by him for the outward supplies made through his Portal, within 10 days of the end of the calendar month to which such statement pertains. The return should contain the names of the actual supplier(s), details of respective supplies made by them and the amount collected on their behalf.

Q 14. How can actual suppliers claim credit of this TCS?

Ans. TCS which is deposited by the operator into government account will be reflected in the electronic cash ledger of the actual registered supplier (on whose account such collection has been made) on the basis of the valid return filed by the operator. The actual supplier can use the same at the time of discharge of tax liability in respect of the supplies.

Q 15. What is the concept of matching in e-commerce provisions and how it would work?

Ans. The details of supplies and the amount collected during a calendar month which is furnished by every operator in his return will be matched with the corresponding details of outward supplies furnished by the concerned supplier in his valid return filed under section 32 for the same calendar month or any preceding calendar month. Where the details of outward supply, on which the tax has been collected, as declared by the operator in his statement do not match with the corresponding details declared by the supplier the discrepancy will be communicated to both persons.

Q 16. What will happen if the details remain mismatched?

Ans. The value of a supply relating to any payment in respect of which any discrepancy is communicated and which is not rectified by the supplier in his valid return for the month in which discrepancy is communicated, the same will be added to the output liability of the said supplier in the subsequent month succeeding in which the discrepancy is communicated. The concerned supplier will, in whose output tax liability any amount has been added, will be liable to pay the tax payable in respect of such supply along with interest on the amount so added from the date such tax was due till the date of its payment.

MCQ

1. What is e-commerce?
- (a) Supply of goods and/or on an on an electronic platform for commerce other than the e-commerce operator himself
 - (b) Supply of goods and/or services on an on an electronic platform for commerce including the e-commerce operator
 - (c) Supply of goods and/or services on an electronic platform for commerce
 - (d) Supply of goods and/or services including digital products on an on an electronic platform for commerce

Ans. (d) *Supply of goods and/or services including digital products on an on an electronic platform for commerce*

2. A person who _____ an electronic platform for electronic commerce shall be considered as an e-commerce operator.
- (a) Owns
 - (b) Operates
 - (c) Manages
 - (d) Any of the above

Ans. (d) *Any of the above*

3. At what rate should the tax be collected at source?
- (a) 0.5%
 - (b) 1%
 - (c) 2%
 - (d) 3%

Ans. (b) 1% (1% of CGST and 1% of SGST)

4. Is there any threshold limit for applying the provisions of Section 56 for collecting tax at source?
- (a) TCS applies if net value of taxable supplies exceeds ₹ 10,00,000/-
 - (b) TCS applies if net value of taxable supplies exceeds ₹ 15,00,000/-
 - (c) TCS applies if net value of taxable supplies exceeds ₹ 20,00,000/-
 - (d) No such limit prescribed, tax should always be collected at source if the conditions u/s 56 are met.

Ans. (d) *No such limit prescribed, tax should always be collected at source if the conditions u/s 56 are met*

5. When will Section 56 apply? Or when should the e-commerce operator collect tax at source?
- (a) E-commerce operator should always collect tax at source
 - (b) E-commerce operator should collect tax at source only if the supplier of the goods and/or is registered
 - (c) E-commerce operator should collect tax at source in respect of supplies where the consideration is collected by him on behalf of the supplier
 - (d) E-commerce operator should collect tax at source only if the net value of taxable supplies exceeds certain threshold

Ans. (c) E-commerce operator should collect tax at source in respect of supplies where the consideration is collected by him on behalf of the supplier

6. What does net value of taxable supplies include?
- (a) Aggregate value of all the supplies of goods and/or services made during any month by all registered taxable persons through the e-commerce operator
 - (b) Aggregate value of all the supplies of goods and/or services made during any month by all registered taxable persons through the e-commerce operator reduced by value of taxable supplies returned to the suppliers during the said month
 - (c) Aggregate value of all the supplies of goods and/or services, excluding the services notified u/s 8(4) made during any month by all registered taxable persons through the e-commerce operator reduced by value of taxable supplies returned to the suppliers during the said month
 - (d) Aggregate value of all the supplies of goods and/or services, excluding the services notified u/s 8(4) made during any month by a registered taxable person through the e-commerce operator reduced by value of taxable supplies returned to the suppliers during the said month

Ans. (c) Aggregate value of all the supplies of goods and/or services, excluding the services notified u/s 8(4) made during any month by all registered taxable persons through the e-commerce operator reduced by value of taxable supplies returned to the suppliers during the said month

7. When can a supplier opt not to register?
- (a) Always
 - (b) When the e-commerce operator is not required to collect tax at source u/s 56
 - (c) When the supplier doesn't cross the threshold limit mentioned under Schedule V
 - (d) Option (b) and (c), cumulatively fulfilled

Ans. (d) Option (b) and (c), cumulatively fulfilled

8. When is an e-commerce operator required to register?
- (a) When he is required to collect tax at source u/s 56
 - (b) When his aggregate turnover exceeds the threshold limit
 - (c) When he is required to discharge tax on the taxable supply or services made by the supplier through him u/s 8(4)
 - (d) Always

Ans. (d) Always

9. Is every supplier on e-commerce platform covered under Section 56 required to charge GST from Re. 1?
- (a) Yes
 - (b) No

Ans. (a) Yes

10. When should the e-commerce operator collect tax at source?
- (a) When he collects the consideration on behalf of the supplier
 - (b) When he remits the consideration to the supplier
 - (c) Option (a) or (b) whichever is earlier
 - (d) Option (a) or (b) whichever is later

Ans. (a) When he collects the consideration on behalf of the supplier

11. Tax shall not be collected at source on the amounts adjusted by the e-commerce operator against the amounts receivable from the supplier.
- (a) Yes, e-commerce operator is entitled to collect tax at source only on the final/net amount paid to the supplier
 - (b) No, e-commerce operator should collect tax at source on the entire amount of consideration collected by him

Ans. (b) No, e-commerce operator should collect tax at source on the entire amount of consideration collected by him

12. In case the e-commerce operator agrees to bear a part of the discount offered by the supplier on the products, is the e-commerce operator required to collect tax at source on such discount borne by him?
- (a) Yes, as this can be considered as consideration received from the customer
 - (b) No, this cannot be considered as consideration received from the customer

Ans. (a) Yes, as this can be considered as consideration received from the customer

13. When should the e-commerce operator remit the amount of TCS to government and file the necessary returns with the government?
- (a) Within 10 days after the end of the month in which such amount was collected
 - (b) Within 10 days after the end of the month in which such amount was collected, but no time limit for filing the return
 - (c) Within 10 days after the end of the month in which such amount was collected, but no time limit for paying the money
 - (d) No time limit for both

Ans. (a) Within 10 days after the end of the month in which such amount was collected

14. Can the supplier take credit of the TCS?
- (a) Yes
 - (b) No
 - (c) Yes, on the basis of the valid return filed
 - (d) Yes, on the basis of a valid return filed by the e-commerce operator and there is no discrepancy in the returns

Ans. (d) Yes, on the basis of a valid return filed by the e-commerce operator and there is no discrepancy in the returns

15. Is there any matching to be done with the returns filed?
- (a) Yes, return of e-commerce operator should be matched with every return of supplier
 - (b) No, no such requirement mandated
 - (c) Yes, return of e-commerce operator should be matched with every return of supplier but no consequences if the returns do not match
 - (d) Yes, return of e-commerce operator should be matched with every return of supplier and if the returns do not match then the amount of discrepancy will be added to the outward tax liability of the e-commerce operator

Ans. (d) Yes, return of e-commerce operator should be matched with every return of supplier and if the returns do not match then the amount of discrepancy will be added to the outward tax liability of the e-commerce operator

CHAPTER XIV

Assessment

FAQ

Provisional Assessment (Section 58)

- Q 1. How is the assessment made if the taxable person is not able to determine the value of goods and/or services or determine the rate of tax?
- Ans. Where the taxable person is unable to determine the value of goods and/or services or determine the rate of tax applicable thereto, he may request the proper officer in writing giving reasons for payment of tax on a provisional basis and the proper officer may pass an order allowing payment of tax on provisional basis at such rate or on such value as may be specified by him.
- Q 2. Whether Self-Assessment and provisional assessment are mutually exclusive?
- Ans. Yes, if the taxable person opts for self-assessment, he cannot opt for provisional assessment for the same period for same supply. However, he can opt for provisional assessment if he is unable to determine taxable value / tax liability/ (rate of tax) for any subsequent periods.
- Q 3. Whether proper officer can reject the application to provisional assessment submitted by taxable person?
- Ans. Yes. The provisions relating to provisional assessments provide discretionary powers on the proper officer to pass an order allowing the taxable person to remit tax on provisional basis.
- Q 4. What conditions needs to be satisfied by a taxable a person for assessment of taxes on provisional basis?
- Ans. The proper officer may allow for payment of tax on provisional basis subject to execution of bond in prescribed form along with surety / security as the proper officer may deem fit, binding the taxable person for differential tax if any.
- Q 5. What is the time limit for passing final assessment order in case of provisional assessment?
- Ans. The proper officer shall, within a period of six months from the date of communication of the provisional assessment order, pass the final assessment order after taking into

account such information as may be required for finalizing the assessment. However, the time limit of six months can be further extended on sufficient cause being shown and for reasons to be recorded in writing in the following manner:

- (a) by the Joint / Additional Commissioner for a further period of six months;
- (b) by the Commissioner for such further period as he may deem fit.

Q 6. What are the consequences on conclusion of provisional assessment by way of passing final assessment order in so far as short / excess remittance of tax is concerned?

Ans. The consequences on concluding the provisional assessment by way of passing final assessment order would be as follows:

- (a) Additional tax liability: In case of short remittance of taxes in terms of final assessment order, the additional tax liability, if any should be remitted along with interest at the rate prescribed under Section 45(1) for delay in remittance of taxes viz., due date of remittance as prescribed under Section 34(7) till the date of actual payment;
- (b) Excess remittance of tax on provisional basis: In case of excess remittance of taxes in terms of final assessment order, the taxable person is entitled to refund of such excess remittance subject to Section 48(8) along with interest as provided under Section 50.

Scrutiny of Returns (Section 59)

Q 7. What does scrutiny of returns mean under Revised Model GST Law?

Ans. The Revised Model GST Law empowers proper officer to scrutinise the return and related particulars furnished by the taxable person to verify the correctness of the return. The manner in which scrutiny of returns should be conducted is yet to be prescribed.

In case of any discrepancies, the proper officer should seek explanation from taxable person. On receipt of satisfactory explanation, the proper officer is not required to take any further action.

In the event, after accepting the discrepancies, no satisfactory explanation is furnished within a period of thirty days or such further extended time or if the taxable person fails to take the corrective measures in the return for the month in which discrepancy is accepted, the proper officer may initiate audit under Section 63 or special audit under Section 64 or inspection, search and seizure under Section 79 or proceed to determine the tax and other dues under section 66 (7) or section 67(7).

Q 8. Whether any time limit has been specified to issue notice for scrutiny?

Ans. No, the provisions relating to scrutiny assessments do not specify time limit for issuing notice for scrutiny of assessments.

Q 9. What action the proper officer may take in case no satisfactory explanation is sought after the discrepancies are brought to the notice of the taxable person?

Ans. In case, after accepting the discrepancies, no satisfactory explanation is furnished within a period of thirty days or such further period as may be permitted, proper officer may:

- (a) Initiate Audit of accounts by the tax authorities under section 63; or
- (b) Initiate special audit under Section 64; or
- (c) Initiate inspection, search and seizure under Section 79; or
- (d) proceed to determine the tax and other dues under Section 67(7) and Section 66 (7).

Assessment of non-filers of returns (Section 60)

Q 10. Whether, Revised Model GST Law provides for assessment in case of taxable person who does not furnish returns under Section 34 and 40?

Ans. In terms of Section 60(1) of the Revised Model GST Law, the proper officer is empowered to assess the tax liability on such taxable person to the best of his judgment taking into account all the relevant materials which is available or which is gathered and issue an assessment order within a period of five years from the due date of filing annual return for the "relevant year".

Q 11. Is there any additional opportunity provided for taxable person to submit a return even after passing an assessment order under sec 60(1)?

Ans. Yes, if the taxable person furnishes a valid return within thirty days from the date of service of best judgment assessment order under Section 60 (1), the said assessment order shall be deemed to have been withdrawn.

Q 12. Whether the taxable person will get immunity from interest & late fee leviable if assessment order passed under Section 60(1) is withdrawn?

Ans. No, taxable person will still be liable for interest under Section 45 and late fee under Section 42.

Assessment of unregistered persons (Section 61)

Q 13. Whether, Revised Model GST Law provides for assessment of taxes on the unregistered taxable person who fails to take registration even though liable to do so?

Ans. If a taxable person fails to obtain registration even though liable to do so, the proper officer may assess the tax liability to the best of his judgment after issuance of a proper show cause notice and after providing opportunity of being heard to such unregistered taxable person.

Q 14. Time limit for passing the assessment order on the unregistered taxable person who has failed to obtain registration?

Ans. The proper officer, in relation to assessment of taxes on the unregistered taxable person, shall issue the assessment order within 5 years from the due date for filing annual return of relevant year.

Summary assessment in certain special cases (Section 62)

Q 15. Whether proper officer can proceed, *suo - moto* in assessing the tax liability of a taxable person on possession of relevant evidence?

Ans. No, the proper officer has to obtain prior permission of Additional /Joint Commissioner to proceed to assess the tax liability.

Q 16. Whether the summary assessment can be initiated based on mere change in opinion of proper officer?

Ans. No, mere change in opinion cannot be treated as evidence for initiation of summary assessment.

Q 17. Whether summary assessment can only be initiated on previously filed return (u/s 34 and u/s 40)?

Ans. Summary assessment can be initiated on any taxable person. Submission of return u/s 34 and u/s 40 is not a prerequisite.

Q 18. What is the remedy available to the taxable person if the order passed u/s 62 is erroneous?

Ans. On an application made within thirty days by taxable person from the date of receipt of summary assessment order the Additional/Joint Commissioner may withdraw such order and follow the procedure laid down in Section 66 or 67 which provides for determination of tax liability on account of tax not paid other than fraud, willful mis-statement etc., or otherwise respectively.

Q 19. Whether the Additional / Joint Commissioner can withdraw the summary assessment order only on application by the taxable person?

Ans. The Additional / Joint Commissioner can also withdraw the summary assessment order in the event such order is erroneous and thereafter may follow the procedure laid down

in Section 66 or 67 which provides for determination of tax liability on account of tax not paid other than fraud, wilful mis-statement etc., or otherwise respectively.

MCQ

Provisional Assessment (Sec 58)

1. A Taxpayer may apply for provisional assessment:
- (a) when the taxable person is not able to determine the value of goods and/or services
 - (b) when the taxable person is not able to determine the rate of tax.
 - (c) (a) or (b)
 - (d) (a) and (b)

Ans. (c) (a) or (b)

2. The provisional assessment sought by a taxable person can be used by:
- (a) The taxable person who has sought the provisional assessment.
 - (b) The friends and relatives of the taxable person who has sought the provisional assessment.
 - (c) The holding/subsidiary company of the taxable person who has sought the provisional assessment.
 - (d) None of the above.

Ans. (a) The taxable person who has sought the provisional assessment.

3. The payment of tax on provisional basis may be allowed, if the taxable person:
- (a) executes a bond in such form as may be prescribed in this behalf
 - (b) with such surety or security as the proper officer may deem fit, binding the taxable person for differential tax if any.
 - (c) (a) or (b)
 - (d) (a) & (b)

Ans. (d) (a) & (b)

4. What is the time period within which the final assessment order should be passed?
- (a) Six months from the date of the provisional assessment.
 - (b) Nine months from the date of the provisional assessment.

- (c) Three months from the date of the provisional assessment.
- (d) One year months from the date of the provisional assessment.

Ans. (a) Six months from the date of the provisional assessment

5. If final order is not passed within six months, time period specified in 58(1) may, on sufficient cause being shown and for reasons to be recorded in writing, be extended:
- (a) by the Joint/Additional Commissioner for a further period of six months and by the Commissioner for such further period as he may deem fit.
 - (b) by the Commissioner for a further period of six months.
 - (c) by the Joint/Additional Commissioner for a further period of one year.
 - (d) by the Joint/Additional Commissioner for a further period of one year and by the Commissioner for a further period of six months.

Ans. (a) by the Joint/Additional Commissioner for a further period of six months and by the Commissioner for such further period as he may deem fit

6. Whether any additional interest/penalty/prosecution will be leviable for non-payment of tax determined under provisional assessment?
- (a) Only interest specified under section 45 will be liable.
 - (b) Interest u/s 45 + Penalty of ₹ 10,000.
 - (c) Only Penalty @ 50% of the default amount.
 - (d) No Penalty, only Prosecution.

Ans. (a) Only interest specified under section 45 will be liable

7. What shall be interest payable to the taxable person if he is entitled to a refund consequent to the order for final assessment?
- (a) Interest shall be payable only after 6 months after the final Assessment.
 - (b) Interest shall be payable only after 3 months after the final Assessment.
 - (c) interest shall be paid on such refund as provided in section 50.
 - (d) No interest shall be payable on the refund.

Ans. (c) interest shall be paid on such refund as provided in section 50.

8. What will be consequences when tax payable under final order passed under sub-section (3) is more than tax paid based on provisional assessment?
- (a) Only Differential tax payable has to be paid on determination of final assessment.
 - (b) Differential tax payable has to be paid on determination of final assessment along with interest specified under section 45.

- (c) Differential tax payable has to be paid on determination of final assessment along with interest specified under sec 45 and penalty of ₹ 20,000.
- (d) Differential tax payable has to be paid on determination of final assessment along with penalty of ₹ 20,000.

Ans. (b) Differential tax payable has to be paid on determination of final assessment along with interest specified under section 45.

Scrutiny of Returns (Section 59)

9. Whether all the returns submitted under Sec 34 will be scrutinised?
- (a) No, 50% of the returns submitted under Sec 34 will be scrutinised.
 - (b) Yes, all the returns submitted under Sec 34 will be scrutinised.
 - (c) No, Returns submitted under Sec 34 will be self-assessed and proper officer may select any return for scrutiny under this section.
 - (d) No, 35% of the returns submitted under Sec 34 will be scrutinised.

Ans. (c) No, Returns submitted under Sec 34 will be self-assessed and proper officer may select any return for scrutiny under this section

10. Whether any time limit has been specified to issue notice for scrutiny?
- (a) Six months from the end of the respective financial year.
 - (b) No time limit has been prescribed as of now, however same may be prescribed in the rules.
 - (c) One Year from the end of the respective financial year.
 - (d) 3 Years from the end of the respective financial year.

Ans. (b) No time limit has been prescribed as of now, however same may be prescribed in the rules.

11. In case no satisfactory explanation is furnished for the discrepancies within a period of thirty days of being informed by the proper officer or such further period as may be permitted proper officer may initiate appropriate action:
- (a) under section 63 (Audit)
 - (b) Section 64 (Special Audit)
 - (c) section 79, (Inspection, Search Seizure)
 - (d) proceed to determine the tax and other dues under sub-section (7) of section 66 or under sub-section (7) of section 67.

- (e) Any of the above.

Ans. (e) Any of the above

Assessment of Non- filers of returns (Section 60)

12. Is there any time limit specified to furnish the return after serving of notice?
- (a) Yes, Return has to be filed by taxable person who has failed to submit return under Sec 34 or Sec 40 within 15 days from service the notice.
 - (b) Yes, Return has to be filed by taxable person who has failed to submit return under Sec34 or Sec 40 within 30 days from service the notice.
 - (c) Yes, Return has to be filed by taxable person who has failed to submit return under Sec34 or Sec 40 within 45 days from service the notice.
 - (d) No time limit has been specified.

Ans. (a) Yes, Return has to be filed by taxable person who has failed to submit return under Sec 34 or Sec 40 within 15 days from service the notice

13. What are the consequences, where a registered taxable person fails to furnish the return required under section 34 or section 40, even after the service of a notice under section 41?
- (a) The proper officer may proceed to assess the tax liability of the said person to the best of his judgement.
 - (b) Issue an assessment order within the time limit specified in sub-section (8) of section 67.
 - (c) (a) or (b)
 - (d) (a) and (b)

Ans. (c) (a) or b)

14. If the taxable person furnishes a valid return withinof the service of the assessment order u/s 60 (1), the said assessment order shall be deemed to have been withdrawn.
- (a) 30 days
 - (b) 60 days
 - (c) 1 month
 - (d) 2 months.

Ans. (a) 30 days

15. Whether the taxable person will get immunity from interest & late fee leviable if assessment order passed u/s 60(1) is withdrawn?

- (a) Taxable person will get immunity only from late fee u/s 42.
- (b) No, taxable person will still be liable for interest u/s Sec 45 and late fee u/s Sec 42. Therefore, no immunity has been provided for the same.
- (c) Taxable person will get immunity from late fee u/s 42 as well as interest u/s 45.
- (d) Taxable person will get immunity only from interest u/s 45.

Ans. (b) No, taxable person will still be liable for interest u/s Sec 45 and late fee u/s Sec 42. Therefore, no immunity has been provided for the same.

Assessment of unregistered persons (Section 61)

16. What is the consequence, where a taxable person fails to obtain registration even though liable to do so?

- (a) Proper Officer may assess the tax liability to the best of his judgement.
- (b) Issue a show cause notice and pass assessment order after providing opportunity of being heard.
- (c) (a) or (b)
- (d) (a) and (b)

Ans. (c) (a) or (b)

17. What are the pre requisites for proper officer to pass assessment order under Sec 61?

- (a) Period selected for assessment has to be within 5 years from the end of due date for filing annual return of relevant period.
- (b) Show cause notice has to be issued before passing assessment order.
- (c) Opportunity of being heard has to be given before passing assessment order.
- (d) All of the above.

Ans. (d) All of the above

Summary assessment in certain special cases (Section 62)

18. Whether the proper officer can proceed suo-moto in assessing the tax liability of a taxable person on possession of relevant evidence?

- (a) No, the proper officer has to obtain prior permission of [Additional/Joint Commissioner] to proceed to assess the tax liability.
- (b) No, the proper officer has to obtain prior permission of Chief Commissioner to proceed to assess the tax liability.
- (c) No, the proper officer has to obtain prior permission of Principle Chief Commissioner to proceed to assess the tax liability.
- (d) Yes, the proper officer can proceed suo-moto in assessing the tax liability of a taxable person on possession of relevant evidence.

Ans. (a) No, the proper officer has to obtain prior permission of [Additional/ Joint Commissioner] to proceed to assess the tax liability

19. Whether summary assessment can only be initiated on previously filed return (u/s 34 and u/s 40)?

- (a) Summary assessment can be initiated on a person who has previously filed the return.
- (b) Summary assessment can be initiated on a person who has previously not filed the return.
- (c) (a) or (b). Submission of return u/s 34 and u/s 40 is not prerequisite.
- (d) Only (b).

Ans. (c) (a) or (b). Submission of return u/s 34 and u/s 40 is not prerequisite

20. The order u/s 62 may be withdrawn:

- (a) On an application made by taxable person,
- (b) If the Additional/Joint Commissioner considers that such order is erroneous.
- (c) (a) or (b)
- (d) The order passed u/s 62 cannot be withdrawn.

Ans. (c) (a) or (b)

Chapter XV

Audit

FAQ

Audit by Tax Authorities (Section 63)

Q 1. Who is authorised to undertake the audit of a taxable person?

Ans. The Commissioner of CGST/Commissioner of SGST or any officer authorised by him, by way of a general or a specific order, may undertake audit of any taxable person for such period, at such frequency and in such manner as may be prescribed.

Q 2. Whether any reason to believe or evidence is required for initiate audit under Section 63?

Ans. No, Sec 63 does not specify any such requirements. Commissioner can initiate audit on any taxable person for such period, at such frequency and in such manner as may be prescribed.

Q 3. Should the taxable person be informed in advance, prior to conduct of audit?

Ans. The taxable person shall be informed, by way of a notice, sufficiently in advance, not less than fifteen working days, prior to the conduct of audit in the manner prescribed.

Q 4. What is the time limit for completion of the audit under Section 63(1) and whether the same can be extended?

Ans. The audit under Section 63(1) shall be completed within a period of three months from the date of commencement of audit. The period of completion of audit can be further extended by a period not exceeding six months by the Commissioner for reasons to be recorded in writing.

Q 5. What are the powers of the authorised officer in the course of audit?

Ans. During the course of audit, the authorised officer may require the taxable person,

- (i) to afford him the necessary facility to verify the books of account or other documents as he may require and which may be available at such place,
- (ii) to furnish such information as he may require and render assistance for timely completion of the audit.

Q 7. What action will be initiated when the audit conducted u/s 63(1) results in a demand?

Ans. Where the audit u/s 63(1) results in detection of tax not paid or short paid or erroneously refunded, or input tax credit wrongly availed or utilized, the proper officer may initiate action under section 66 or 67.

Special Audit (Section 64)

Q 8. In what cases special audit under Section 64 can be directed?

Ans. Special audit can be directed if at any stage of scrutiny, enquiry, investigation or any other proceedings before him, any officer not below the rank of Deputy/Assistant Commissioner is of the opinion that the value has not been correctly declared or the credit availed is not within the normal limits with regard to nature and complexity of the case and interest of revenue, with the prior approval of Commissioner.

Q 9. Whether Special audit can be initiated after completion of scrutiny, enquiry, and investigation?

Ans. No, special audit can be initiated during the process of scrutiny, enquiry, investigation and not after completion of the same.

Q 10. Who can direct the taxable person to get his records audited under Section 64?

Ans. An officer not below the rank of Deputy/Assistant Commissioner may, with the prior approval of the Commissioner, direct a taxable person by a communication in writing to get his records including books of account examined and audited.

Q 11. Whether proper officer nominated by Commissioner will be authorised to conduct the audit including books of account under Section 64?

Ans. No, only Chartered Accountant or a Cost Accountant as may be nominated by the Commissioner in this behalf will be authorised to conduct audit under Section 64.

Q 12. What is the time limit to submit a report of the audit?

Ans. The Chartered Accountant or Cost Accountant nominated to conduct the audit under Section 64, shall submit a report, within a period of ninety days to an officer not below the rank of Deputy / Assistant Commissioner to get the audit of records of such taxable person. The said period of ninety days can be extended by another period of ninety days on an application made in this behalf by the taxable person or the Chartered Accountant or Cost Accountant for any sufficient or material reason.

Q 13. Is the taxable person relieved from audit under Section 64 if the accounts of the taxable person have already been audited under any other provision of this Act or any other law?

Ans. The provision of section 64(1) shall have effect notwithstanding that the accounts of the taxable person have been audited under any other provision of this Act or any other law for the time being in force or otherwise.

Q 14. How are the expenses of audit determined and paid?

Ans. The expenses of, and incidental to, the examination and special audit of records under Section 64(1), including the remuneration of such chartered accountant or cost

accountant, shall be determined and paid by the Commissioner and that such determination shall be final.

Q 15. What action will be initiated when the special audit conducted under Section 64(1) results in a demand?

Ans. Where the special audit conducted under Section 64(1) results in detection of tax not paid or short paid or erroneously refunded, or input tax credit wrongly availed or utilised, the proper officer may initiate action under section 66 or 67, as the case may be.

Power of CAG to call for information for Audit (Section 65)

Q 16. Whether, the Revised Model GST Law empowers the CAG to call for information for audit?

Ans. The proper officer shall, upon request made in this behalf, make available to the Comptroller and Auditor General of India or an officer authorised by him, information, records and returns furnished under the Act, required for conduct of audit as required under the Comptroller and Auditor General's (Duties, Powers and Conditions of Service) Act (56 of 1971)

Chapter – XVI

Demands and Recovery

FAQ

Determination of tax not paid or short paid or erroneously refunded or input tax credit wrongly availed or utilized for any reason other than fraud or any wilful misstatement or suppression of facts (Section 66)

Q 1. When a proper officer shall invoke provisions of section 66(1) to serve show cause Notice on the person chargeable with tax?

Ans. The proper officer shall serve notice on the person chargeable with tax when he has reasons to believe that tax has been not paid or short paid or erroneously refunded or input tax credit wrongly availed or utilized for any reason other than fraud or any wilful misstatement or suppression of facts.

Q 2. What is the time limit for issue of notice by the proper officer under section 66(2)?

Ans. Notice shall be issued by the proper officer at least 3 months (a) prior to completion of 3 years from the due date for filing of annual return for the year to which the tax not paid or short paid or input tax wrongly availed or utilized relates (b) within 3 years from the date of erroneous refund.

Q 3. Whether proper officer can issue similar notice for tax periods other than those covered under section 66(1)?

Ans. Yes. The proper officer may serve a statement under section 66(3) containing details of tax not paid or short paid or erroneously refunded or input tax credit wrongly availed or utilized where the grounds relied upon by the proper officer for such tax periods are the same as are mentioned in the earlier notice issued under section 66(1). The service of such statement shall be deemed to be service of notice on the person chargeable with tax.

Q 4. Can the person chargeable with tax pay the amount of demand along with interest before the issue of notice under sub-section (1) or (3) of section 66?

Ans. Yes. Where the person is chargeable with tax, can pay the amount of tax along with interest under section 45 based on his own ascertainment of such tax or the tax as ascertained by the proper officer and inform the proper officer in writing of such payment. On such payment, no notice shall be issued with respect to the tax so paid.

Q 5. Whether the proper officer can proceed to issue notice in case of shortfall in payment under sub-section (4) by the person chargeable with tax?

Ans. Where the proper officer is of the opinion that the amount paid under sub-section (4) falls short of the actual amount payable, he shall proceed to issue notice for the shortfall.

Q 6. If the notice is issued under section 66(1) or 66(3) and thereafter the Noticee makes payment, is there any need to adjudicate the case?

Ans. No. Where the person chargeable with tax, pays the tax along with interest under section 45 within 30 days of notice, no penalty shall be payable and all proceedings in respect of such notice shall be deemed to be concluded.

Q 7. What is the maximum penalty leviable under section 66?

Ans. Penalty equivalent to 10% of the tax or ₹10,000/- whichever is higher.

Q 8. What is the time limit for issue of the order?

Ans. The Proper officer shall issue the order (a) within 3 years from the due date for filing of annual return for the year to which tax not paid or short paid or input tax credit wrongly availed or utilized relates (b) within 3 years from the date of erroneous refund.

Determination of tax not paid or short paid or erroneously refunded or input tax credit wrongly availed or utilized by reason of fraud or any wilful misstatement or suppression of facts. (Section 67)

Q 9. When a proper officer shall invoke provisions of section 67(1) to serve show cause notice on the person chargeable with tax?

Ans. The proper officer shall serve notice on the person chargeable with tax when he has reasons to believe that tax has been not paid or short paid or erroneously refunded or input tax credit wrongly availed or utilized by reason of fraud or any wilful misstatement or suppression of facts to evade tax.

Q 10. What is the time limit for issue of notice by the proper officer under section 67(2)?

Ans. Notice shall be issued by the proper officer at least 6 months (a) prior to completion of 5 years from the due date for filing of annual return for the year to which the tax not paid or short paid or input tax wrongly availed or utilized relates (b) within 5 years from the date of erroneous refund.

Q 11. Whether proper officer can issue similar notice for tax periods other than those covered under section 67(1)?

Ans. Yes. The proper officer may serve a statement under section 67(3) containing details of tax not paid or short paid or erroneously refunded or input tax credit wrongly availed or utilized where the grounds relied upon by the proper officer for such tax periods are the same as are mentioned in the earlier notice issued under section 67(1). The service of such statement shall be deemed to be service of notice on the person chargeable with tax.

Q 12. Can the person chargeable with tax pay the amount of demand along with interest and reduced penalty before the issue of notice under sub-section (1) or (3) of section 67?

Ans. Yes. Where the person chargeable with tax pay the amount of tax along with interest under section 45 and a penalty equivalent to 15% of such tax based on his own ascertainment of such tax or the tax as ascertained by the proper officer and inform the proper officer in writing of such payment, no notice shall be issued with respect to the tax so paid.

Q 13. Can the person chargeable with tax pay the amount of demand along with interest and reduced penalty after the issue of notice under section 67(1) or 67(3), but before the adjudication and issue of order under section 67?

Ans. Yes. Where, the person chargeable with tax under section 67(1) or the statement under section 67(3) pays the amount of tax along with interest under section 45 and a penalty equivalent to 25% of such tax within 30 days from the issue of notice. Then on such payment, all proceedings in respect of the said tax shall be deemed to be concluded [Section 67(6)].

Q 14. In case a Notice is adjudicated under section 67 and order issued confirming tax demand and penalty, does the Noticee have any option to pay reduced penalty?

Ans. Yes. Where any person served with order under section 67(7) pays the tax along with interest under section 45 and a penalty equivalent to 50% of such tax within 30 days of the communication of the order, then all proceedings in respect of the said tax shall be deemed to be concluded [Section 67(9)].

Q 15. Whether the proper officer can proceed to issue notice in case of shortfall in payment under section 67(4) by the person chargeable with tax?

Ans. Where the proper officer is of the opinion that the amount paid under section 67(4) falls short of the actual amount payable, he shall proceed to issue notice for the shortfall.

Q 16. If the notice is issued under section 67(1) or 67(3) and thereafter the Noticee makes payment, is there any need to adjudicate the case?

Ans. No. Where the person chargeable with tax, pays the tax along with interest under section 45 and applicable penalty within 30 days of notice, all proceedings in respect of such notice shall be deemed to be concluded.

Q 17. What is the maximum penalty leviable under section 67?

Ans. Penalty equivalent to 100% of the tax.

Q 18. What is the time limit for issue of the order?

Ans. The Proper Officer shall issue the order (a) within 5 years from the due date for filing of annual return for the year to which tax not paid or short paid or input tax credit wrongly availed or utilized relates (b) within 5 years from the date of erroneous refund.

Q 19. What is 'Suppression'?

Ans. The term 'Suppression' means non-declaration of facts or information which a taxable person is statutorily required to declare in the return, statement, report or any other document furnished under the Act or the rules made thereunder, or failure to furnish any information on being asked for, in writing by the proper officer.

General provisions relating to determination of tax (Section 68)

Q 20. Where the service of Notice or issuance of order is stayed by a Court order, can the period of such stay be excluded in computing the period specified in sub-sections (2) and (8) of section 66 or sub-sections (2) and (8) of section 67?

Ans. Yes.

Q 21. What happens when the Notice issued under section 67(1) or 67(3) is held not sustainable by any Appellate Authority or Tribunal or Court for the reason that the charges of fraud or any wilful mis-statement or suppression of facts to evade tax has not been established?

Ans. The proper officer shall determine the tax payable by such person for the period of 3 years, deeming as if the Notice were issued under section 66(1) or 66(3) .

Q 22. What is the time limit for issue of order in pursuance of the direction of the Tribunal or Court?

Ans. Order in pursuance of the direction of the Tribunal or Court shall be issued within 2 years from the date of communication of the said direction.

Q 23. Whether opportunity of personal hearing shall be granted to the person chargeable with tax or penalty or any adverse decision without any written request during adjudication proceedings?

Ans. No. An opportunity of personal hearing will be granted only if a request is made in writing

Q 24. How many times adjournments can be sought by the person chargeable with tax during the proceedings?

Ans. If sufficient cause is shown by the person chargeable with tax, the proper officer shall grant time and adjourn the hearing after recording reasons in writing. However, the proper officer shall have the power to grant maximum 3 adjournments during the proceedings.

Q 25. Whether the amount of tax, interest and penalty demanded in the order can exceed the amount specified in the Notice?

Ans. No. Further, the proper officer shall not have powers to confirm demand on grounds other than the grounds specified in the Notice.

Q 26. What happens in cases where Notice is issued but order has not been passed with 3 years (Section 66) or 5 years (Section 67)?

Ans. The adjudication proceedings shall be deemed to be concluded if the order is not issued within 3 years as provided for in sub-section (8) of section 66 or within 5 years as provided for in sub-section (8) of section 67.

Q 27. How to compute period of limitation referred to in section 66(8) or section 67(8), where an issue on which the First Appellate Authority or the Appellate Tribunal or the High Court has given its decision which is prejudicial to the interest of the revenue in some other proceedings and an appeal to the Appellate Tribunal or the High Court or the Supreme Court against such decision is pending?

Ans. While computing the period of limitation referred to in section 66(8) or section 67(8), the period spent between the date of the decision of the First Appellate Authority and the date of the decision of the Appellate Tribunal or the High Court or the Supreme Court shall be excluded.

Q 28. Whether penalties under any other provisions of the Act be imposed in respect of adjudication proceedings under section 66 or 67?

Ans. No. Where any penalty is imposed under section 66 or 67, no penalty for the same act and/or omission shall be imposed under any other provisions of the Act on the same person.

Tax collected but not deposited with the Central or State Government (Section 69)

Q 29. What happens if a person collects tax from another person but does not deposit the same with the Government?

Ans. Every person who has collected from any other person any amount as representing the tax under this Act, shall deposit the said amount to the credit of the Central or a State Government, regardless of whether the supplies in respect of which such amount was collected are taxable or not.

Q 30. In case the person does not deposit tax collected in contravention of Section 69, what is the proper course of action available to the proper officer?

Ans. Issue of Show cause notice, adjudication and issue of order by following principles of natural justice. It is to be noted that such order should be invariably issued within 1 year of date of issue of notice.

Q 31. Is there any time limit for issue of notice under section 69 in cases where tax collected but not paid?

Ans. No. There is no time limit and notice can be issued on detection of such cases without any time limit. Once notice is issued, the order should be passed within 1 year from the date of issue of notice.

Q 32. Whether the person who has borne the incidence of amount apply for refund of surplus left after adjustment towards tax collected but not paid under section 69?

Ans. Yes. The person who has borne the incidence of the amount may apply for the refund of the same in accordance with the provisions of section 48 within 6 months from the date of issue of public notice.

Tax wrongfully collected and deposited with the Central or State Government (Section 70)

Q 33. What happens if a taxable person has paid CGST/SGST (in SGST Act) on a transaction considered by him to be an intra-state supply but which is subsequently held to be an inter-state supply?

Ans. Refund of CGST/SGST (in SGST Act) shall be granted in such manner and subject to such conditions as may be prescribed.

Q 34. Whether a taxable person who has paid IGST on a transaction considered by him to be an inter-state supply, but which is subsequently held to be an intra-state supply is required to pay interest?

Ans. No. Taxable person shall not be required to pay any interest on the amount of CGST/SGST payable.

Initiation of recovery proceedings (Section 71)

Q 35. Is there any time limit for payment of tax demand?

Ans. The demand shall be paid by the taxable person within a period of 90 days from the date of service of the order. However, if it is expedient in the interest of the revenue, the proper officer after recording reasons in writing, he may require the taxable person to make such payment within shorter period as may be specified by him.

Recovery of tax (Section 72)

Q 36. What are the modes of recovery of tax available to the proper officer?

Ans. The following options are available to the proper officer:

- (a) The proper officer may deduct or may require any other specified officer to deduct the amount so payable from any money owing to such person - Refund adjustment.
- (b) The proper officer may recover or may require any other specified officer to recover the amount so payable by detaining and selling any goods belonging to such person – Detaining and selling of goods.
- (c) The proper officer may, by a notice in writing, require any other person from whom money is due or may become due to such person or who holds or may subsequently hold money for or on account of such person, to pay to the credit of the Central or a State Government – Recovery from third parties.
- (d) The proper officer may, on an authorization by the competent authority, detain any movable or immovable property belonging to or under the control of such person, and detain the same until the amount payable is paid; if the due remains unpaid for a period of thirty days after any such distress, he may cause the said property to be sold and with the proceeds of such sale, may satisfy the amount payable and the costs including cost of sale remaining unpaid and pay the surplus amount, if any, to such person – Detaining / attachment of movable or immovable property and adjustment of tax dues from sale proceeds.
- (e) The proper officer may prepare a certificate signed by him specifying the amount due from such person and send it to the Collector of the district in which such person owns any property or resides or carries on his business and on receipt of such certificate, the Collector shall proceed to recover from such person the amount specified as if it were an arrear of land revenue – Recovery of tax dues as arrears of land revenue.

Bar on recovery proceedings (Section 73)

Q 37. Is stay on recovery proceedings automatic on filing of appeal under section 98 (before First Appellate Authority) or section 101 (before the Appellate Tribunal)?

Ans. Yes. Where a person has filed an appeal before the First Appellate Authority or before the Appellate Tribunal against the order of demand, the proper officer may not enforce the payment of demand until the appeal is resolved. If the appeal is not filed against the order of demand, the proper officer can enforce recovery of any amount due under this Act.

Payment of tax and other amount in instalments (Section 74)

Q 38. Can the proper officer allow payment of tax dues in instalments?

Ans. Yes, on an application made by a taxable person, the Commissioner/Chief Commissioner may allow payment of any amount due under the Revised Model Law, other than the amount due as per the liability self-assessed in any return, by such person in monthly instalments not exceeding twenty-four, subject to payment of interest under section 45 with such restrictions and conditions as may be prescribed. However, where there is default in payment of any one instalment on its due date, the whole outstanding balance payable on such date shall become due and payable forthwith and recovered without any further notice.

Transfer of property to be void in certain cases (Section 75)

Q 39. What happens if a person after any amount has become due from him, creates a charge on or parts with the property belonging to him or in his possession by way of sale, mortgage, or any other mode of transfer whatsoever of any of his properties in favour of any other person with the intention of defrauding the Government revenue?

Ans. Such charge or transfer shall be void against any claim in respect of any tax or any other sum payable by the said person. However, such charge or transfer shall not be void if it is made for adequate consideration and without notice of the pendency of such proceedings under the Act or without notice of such tax or other sum payable by the said person or with the previous permission of the proper officer.

Tax to be first charge on the property (Section 76)

Q 40. Whether any amount payable under this Act by the taxable person is a first charge on his property?

Ans. Yes. Notwithstanding anything to the contrary contained in any law for the time being force, first charge shall be on –

- (a) the property of taxable person in respect of any amount payable by such taxable person, or
- (b) the property of any other person on account of tax, interest or penalty which he is liable to pay to the Central or State Government.

Provisional attachment to protect the revenue in certain cases (Section 77)

Q 41. Whether property of a taxable person be provisionally attached to protect the revenue?

Ans. Yes. During the pendency of any proceedings under section 60, 61, 62, 66, 67 or 79, the Commissioner may by order in writing attach any property including bank account

belonging to a taxable person provisionally for the purpose of protecting the interest of the Government revenue. However, every such provisional attachment order shall cease to have effect after the expiry of 1 year from the date of such order.

Continuation and validation of certain recovery proceedings (Section No: 78)

Q 42. What happens in cases where the tax demand confirmed is enhanced in appeal / revision proceedings?

Ans. The notice of demand is required to be served only in respect of the enhanced dues. In so far as the amount already confirmed prior to disposal of appeal/revision, the recovery proceedings may be continued from the stage at which such proceedings stood immediately before such disposal.

Q 43. What happens in cases where the tax demand confirmed is reduced in appeal / revision proceedings?

Ans. The fresh notice of demand is not required to be served in respect of the reduced dues. The Commissioner shall give an intimation of such reduction to the taxable person and the appropriate authority with whom the recovery proceeding is pending. The recovery proceedings already initiated prior to the disposal of such appeal/revision may be continued in relation to the amount so reduced from the stage at which such proceedings stood immediately before such disposal.

MCQ

Determination of tax not paid or short paid or erroneously refunded or input tax credit wrongly availed or utilized by reason of/other than fraud or any wilful- misstatement or suppression of facts (Section 66 and 67)

Q 1. What is the time limit for issue of order in case of fraud, misstatement or suppression?

- (a) 30 months
- (b) 18 months
- (c) 5 years
- (d) 3 years

Ans. (c) 5 years

Q 2. What is the time limit for issue of order in case of other than fraud, misstatement or suppression?

- (a) 30 months
- (b) 18 months
- (c) 5 years
- (d) 3 years

Ans. (d) 3 years

Q 3. Is it obligatory on the part of the Department to take on record the assessee's representation?

- (a) Yes
- (b) No
- (c) At proper officer's discretion
- (d) If requested by notice

Ans. (a) Yes

Q 4. What is the maximum amount of demand for which the officer can issue an order under section 66 in case of other than fraud, misstatement or suppression?

- (a) Amount of tax + interest + penalty of 10% of tax
- (b) Amount of tax + interest + penalty of 10% of tax or ₹ 10,000/- whichever is higher
- (c) ₹ 10,000/-
- (d) Amount of tax + interest + 25% penalty

Ans. (b) Amount of tax + interest + penalty of 10% of tax or ₹ 10,000/- whichever is higher

Q 5. What is the maximum amount of demand for which the officer can issue an order under section 67 in case fraud, misstatement or suppression?

- (a) Amount of tax + interest + penalty of 15% of tax
- (b) Amount of tax + interest + penalty of 25% of tax
- (c) Amount of tax + interest + penalty of 50% of tax
- (d) Amount of tax + interest + penalty of 100% of tax

Ans. (d) Amount of tax + interest + penalty of 100% of tax

General provisions relating to determination of tax (Section 68)

Q 6. Where the service of Notice or issuance of order is stayed by a Court order, can the period of such stay be excluded in computing the period specified in sub-sections (2) and (8) of section 66 and section 67?

- (a) Yes
- (b) No
- (c) At proper officer's discretion
- (d) None of the above

Ans. (a) Yes

Q 7. Whether opportunity of personal hearing shall be granted to the person chargeable with tax or penalty or any adverse decision without any written request during adjudication proceedings?

- (a) Yes
- (b) No
- (c) At proper officer's discretion
- (d) None of the above

Ans. (b) No

Q 8. What is the maximum number of times a hearing can be adjourned?

- (a) 1
- (b) 3
- (c) 5
- (d) None of the above

Ans. (b) 3

Q 9. Whether the amount of tax, interest and penalty demanded in the order can exceed the amount specified in the Notice?

- (a) Yes
- (b) No
- (c) At proper officer's discretion
- (d) None of the above

Ans. (b) No

Q 10. Whether penalties under any other provisions of the CGST/ SGST Law be imposed in respect of adjudication proceedings under section 66 or 67?

- (a) Yes
- (b) No
- (c) At proper officer's discretion
- (d) None of the above

Ans. (b) No

Tax collected but not deposited with the Central or State Government (Section 69)

Q 11. Any amount of tax collected shall be deposited to the credit of the Central or State Government:

- (a) Only when the supplies are taxable
- (b) Regardless of whether the supplies in respect of which such amount was collected are taxable or not
- (c) Only when the supplies are not taxable
- (d) None of the above

Ans. (b) Regardless of whether the supplies in respect of which such amount was collected are taxable or not

Q 12. Is there any time limit for issue of notice under section 69 in cases where tax collected but not paid?

- (a) No time limit
- (b) 1 year
- (c) 3 years
- (d) 5 years

Ans. (a) No time limit

Q 13. Within how many years should the proper officer issue an order from the date of issue of notice?

- (a) 1 year
- (b) 2 years
- (c) 3 years
- (d) 4 years

Ans. (a) 1 year

- Q 14. Whether the person who has borne the incidence of amount apply for refund of surplus left after adjustment towards tax collected but not paid under section 69?
- (a) Yes
 - (b) No
 - (c) At proper officer's discretion
 - (d) None of the above

Ans. (a) Yes

Tax wrongfully collected and deposited with the Central or State Government (Section 70)

- Q 15. What happens if a taxable person has paid CGST/SGST (in SGST Act) on a transaction considered by him to be an intra-state supply but which is subsequently held to be an inter-state supply?
- (a) Pay tax and seek refund
 - (b) Adjust against future liability
 - (c) Take re-credit
 - (d) File a suit for recovery

Ans. (a) *Pay tax and seek refund*

- Q 16. What happens if a taxable person has paid IGST (in IGST Act) on a transaction considered by him to be an inter-state supply but which is subsequently held to be an intra-state supply?
- (a) Pay tax and seek refund
 - (b) Adjust against future liability
 - (c) Take re-credit
 - (d) File a suit for recovery

Ans. (a) *Pay tax and seek refund*

- Q 17. Whether a taxable person who has paid IGST on a transaction considered by him to be an inter-state supply, but which is subsequently held to be an intra-state supply is required to pay interest?
- (a) Yes
 - (b) No
 - (c) At proper officer's discretion
 - (d) None of the above

Ans. (b) *No*

Initiation of recovery proceedings (Section 71)

Q 19. The time limit for payment of tax demand is from the date of service of the order,

- (a) 30 days
- (b) 60 days
- (c) 90 days
- (d) 180 days

Ans. (c) 90 days

Q 20. If it is expedient in the interest of the revenue, can the proper officer after recording reasons in writing, require a taxable person to make payment of tax demand within shorter period as may be specified by him?

- (a) Yes
- (b) No
- (c) With prior permission of not below the rank of Joint Commissioner
- (d) None of the above

Ans. (a) Yes

Recovery of tax (Section 72)

Q 21. Recovery of amount payable by a defaulter can be made from,

- (a) Customer
- (b) Bank
- (c) Post Office
- (d) All of the above

Ans. (d) All of the above

Bar on recovery proceedings (Section 73)

Q 22. Is stay on recovery proceedings automatic on filing of appeal under section 98 (before First Appellate Authority) or section 101 (before the Appellate Tribunal)?

- (a) Yes
- (b) No
- (c) At proper officer's discretion
- (d) None of the above

Ans. (a) Yes

Payment of tax and other amount in instalments (Section 74)

Q 23. The following amounts due cannot be paid through instalments,

- (a) Self-assessed tax shown in return
- (b) Short paid tax for which notice has been issued
- (c) Arrears of tax
- (d) Concealed tax

Ans. (a) *Self-assessed tax shown in return*

Q 24. Maximum number of monthly instalments permissible under section 74 is:

- (a) 36
- (b) 12
- (c) 48
- (d) 24

Ans. (d) 24

Q 25. Which officer/s has the power to grant permission for payment of tax through instalment?

- (a) Commissioner
- (b) Chief Commissioner
- (c) Assistant Commissioner
- (d) Both (a) and (b)

Ans. (d) *Both (a) and (b)*

Transfer of property to be void in certain cases (Section 75)

Q 26. Which of the following acts by a person are treated as void when it is done after any amount has become due from him?

- (a) Creates charge on property
- (b) Parts with the property belonging to him
- (c) Parts with the property in his possession
- (d) All of the above

Ans. (d) *All of the above*

Q 27. What all modes of transfers covered under section 75?

- (a) Sale
- (b) Mortgage
- (c) Any other mode of transfer
- (d) All of the above

Ans. (d) All of the above

Q 28. When transfer of property would be considered void?

- (a) Transaction is done to defraud the Government revenue
- (b) Transaction is done without the intention to defraud the Government revenue
- (c) Both (a) & (b)

Ans. (a) Transaction is done to defraud the Government revenue

Q 29. When transfer of property would not be considered void?

- (a) Transaction is done for adequate consideration and without the notice of the pendency of proceedings under the Act
- (b) Transaction is done without the notice of such tax or other sum payable
- (c) With previous permission of the proper officer
- (d) All of the above

Ans. (d) All of the above

Tax to be first charge on the property (Section 76)

Q 30. Whether any amount payable under this Act by the taxable person is a first charge on his property?

- (a) Yes
- (b) No
- (c) None of the above

Ans. (a) Yes

Q 31. What liabilities can be recovered under this section?

- (a) Tax
- (b) Interest
- (c) Penalty
- (d) All of the above

Ans. (d) All of the above

Provisional attachment to protect the revenue in certain cases (Section 77)

Q 32. Whether property of a taxable person be provisionally attached to protect the revenue?

- (a) Yes
- (b) No
- (c) None of the above

Ans. (a) Yes

Q 33. Who is competent authority for passing an order for provisional attachment?

- (a) The Deputy Commissioner
- (b) The Commissioner
- (c) The GST Council
- (d) The Assistant Commissioner

Ans. (b) *The Commissioner*

Q 34. Till what period does the order passed for provisional attachment is valid?

- (a) Infinite period
- (b) Ten years
- (c) One year
- (d) Till the end of such proceedings

Ans. (c) *One year*

Q 35. Provisional attachment can be done under section 77:

- (a) Before completion of proceedings
- (b) After completion of proceedings
- (c) After 3 attempts to recover dues
- (d) Only if there is risk of delinquency in payment of dues

Ans. (a) *Before completion of proceedings*

Continuation and validation of certain recovery proceedings (Section 78)

Q 36. When Commissioner can issue a fresh notice to recover the Government dues?

- (a) Demand amount is enhanced
- (b) Demand amount is reduced
- (c) Both (a) and (b)

Ans. (a) *Demand amount is enhanced*

Q 37. When Commissioner is not required to serve fresh notice to recover the Government dues?

- (a) Demand amount is reduced
- (b) Already proceedings of recovery of Government dues is served before disposal of appeal, revision of application or other proceedings
- (c) Demand amount is enhanced
- (d) Both (a) and (b)

Ans. (d) Both (a) and (b)

Q 38. Who can issue fresh notice for enhanced demand by appeal, revision of application or other proceedings?

- (a) Commissioner
- (b) Assistant Commissioner
- (c) Joint Commissioner
- (d) Any of above

Ans. (a) Commissioner

Chapter – XVII

Inspection, Search, Seizure and Arrest

FAQ

Power of inspection, search and seizure (Section 79)

Q 1. What is the meaning of the term “Search”?

Ans. The term ‘search’, in simple language, denotes an action of a government machinery to go, look through or examine carefully a place, area, person, object etc. in order to find something concealed or for the purpose of discovering evidence of a crime. The search of a person or vehicle or premises etc. can only be done under proper and valid authority of law.

Q 2. What is the meaning of the term “Inspection”?

Ans. It is a softer provision than search to enable officers to access any place of business of a taxable person and also any place of business of a person engaged in transporting goods or a person who is an owner or an operator of a warehouse or godown.

Q 3. What is the meaning of the term “Seizure”?

Ans. In Law Lexicon Dictionary, ‘seizure’, is defined as the act of taking possession of property by an officer under legal process. It generally implies taking possession, forcibly contrary to the wishes of the owner of the property or who has the possession and who was unwilling to part with the possession.

Q 4. Who can order for carrying out ‘Inspection’ and under what circumstances?

Ans. As per Section 79, Inspection can be carried out by an officer of CGST/SGST only upon a written authorization given by an officer of the rank of Joint Commissioner or above. A Joint Commissioner or an officer higher in rank can give such authorization only if he has reasons to believe

1. that the person concerned has –
 - (a) suppressed any transaction of supply of goods and / or services;
 - (b) suppressed stock of goods in hand;
 - (c) claimed excess input tax credit;
 - (d) contravened any provision of the CGST/SGST Act or rules to evade tax;
2. a transporter or warehouse owner or owner of a godown or any other place has

kept goods which have escaped payment of tax or has kept his accounts or goods in a manner that is likely to cause evasion of tax.

Q 5. Which are the places of business/ premises, which can be inspected by the CGST/SGST officer under this section?

Ans. CGST / SGST officer authorized by the rank of Joint Commissioner or above shall have the powers to carry out inspection of any of the following places / premises:

- (a) any places of business of a taxable person;
- (b) any places of business of a person engaged in the business of transporting goods;
- (c) any places of business of an owner or an operator of a warehouse or godown;
- (d) any other place

Q 6. Who can order for search and seizure and under what circumstances?

Ans. An officer of the rank of Joint Commissioner or above can authorize an officer in writing to carry out search and seizure of goods, documents, books or things. Such authorization can be given only where the Joint Commissioner has reasons to believe that any goods liable to confiscation or any documents or books or things, which in his opinion shall be useful for or relevant to any proceedings under this Act are secreted / hidden in any place. He may also carry out such search and seizure himself.

Q 7. What is meant by 'reasons to believe'?

Ans. Reason to believe is to have knowledge of facts, which, although not amounting to direct knowledge, would cause a reasonable person, knowing the same facts, to reasonably conclude the same thing. As per Section 26 of the IPC, 1860, "A person is said to have 'reason to believe' a thing, if he has sufficient cause to believe that thing but not otherwise." 'Reason to believe' contemplates an objective determination based on intelligent care and evaluation as distinguished from a purely subjective consideration. It has to be and must be that of an honest and reasonable person based on relevant material and circumstances.

Q 8. Is it mandatory that such 'reasons to believe' has to be recorded in writing by the proper officer, before issuing authorization for Inspection or Search and Seizure?

Ans. Although the officer is not required to state the reasons for such belief before issuing an authorization for search, he has to disclose the material on which his belief was formed. 'Reason to believe' need not be recorded invariably in each case.

Q 9. What are the powers that can be exercised by an officer during search?

Ans. An officer carrying out a search has the power to search for and seize goods (which are liable to confiscation) and documents, books or things (relevant for any proceedings under the Act) from the premises searched. During search, the officer has the power to break open the door of the premises authorized to be searched if access to the same is denied. Similarly, while carrying out search within the premises, he can break open any almirah or box or receptacle if access to such almirah or box or receptacle is denied and in which any goods, account, registers or documents are suspected to be concealed. He can also seal the premises if access to it denied.

Q 10. Whether goods seized can be released on a provisional basis?

Ans. Yes. The goods so seized under section 79(2) can be released on provisional basis upon execution of a bond and furnishing of security in such manner and of such quantum as may be prescribed or on payment of applicable tax, interest and penalty.

Q 11. What are the safeguards provided in section 79 in respect of search and seizure?

Ans. The following are the safeguards provided in section 79 in respect of search and seizure:

- (a) Seized goods or documents should not be retained beyond the period necessary for their examination.
- (b) Photocopies of the documents can be taken by the person from whose custody documents are seized.
- (c) For seized goods, if a notice is not issued within six months of its seizure, goods shall be returned to the person from whose possession it was seized. This period of six months can be extended on justified grounds up to a maximum period of six months.
- (d) An inventory of seized goods shall be made by the officer who has seized goods.
- (e) Certain categories of goods to be specified under Model GST Rules (such as perishable, hazardous etc.) that can be disposed of immediately after seizure.
- (f) Provisions of Code of Criminal Procedure 1973 relating to search and seizure shall apply subject to the modification that section 165(5) of the said Code shall have effect as if for the word "Magistrate", will be substituted by the words Principal Commissioner/Commissioner of CGST/Commissioner of SGST.

Q 12. What is the procedure for conducting search?

Ans. Section 79(10) prescribes that searches must be carried out in accordance with the provisions of Code of Criminal Procedure, 1973.

Inspection of goods in movement (Section 80)

Q 13. Is there any special document required to be carried during transport of taxable goods?

Ans. The person in charge of a conveyance carrying any consignment of goods of value exceeding a specified amount will be required to carry with him such documents and devices as may be prescribed by the Central or State Government. On interception of the conveyance, the person in charge shall produce the prescribed documents and devices for verification and allow inspection of goods by the proper officer.

Power to arrest (Section 81)

Q 14. What is a cognizable offence?

Ans. Generally, cognizable offence means serious category of offences in respect of which a police officer has the authority to make an arrest without a warrant and to start an investigation with or without the permission of a Court.

Q 15. What is a non-cognizable offence?

Ans. Non-cognizable offence means relatively less serious offences in respect of which a police officer does not have the authority to make an arrest without a warrant and an investigation cannot be initiated without the permission of a Court.

Q 16. When can, the proper officer authorize arrest of any person?

Ans. The Commissioner of CGST/SGST can authorize a CGST/SGST officer to arrest a person if he has reasons to believe that the person has committed an offence following under section 92(1) (a), (b), (c), (d) or clause (e) and attracting a punishment prescribed under clauses (i) and (ii) of section 92(1) and 92(2) of the CGST/SGST Law. This essentially means that a person can be arrested only where the tax evasion is more than fifty lakhs rupees or where a person has earlier been convicted for an offence under section 92 of the CGST/SGST Law.

Q 17. What are the safeguards provided for a person who is placed under arrest?

Ans. The following are the safeguards provided for a person who is placed under arrest:

- (a) If a person is arrested for a cognizable offence, he must be informed in writing of the grounds of arrest and he must be produced before a magistrate within 24 hours of his arrest;
- (b) If a person is arrested for a non-cognizable and bailable offence, the Deputy/ Assistant Commissioner of CGST/SGST can release him on bail and the Deputy/ Assistant Commissioner will have same powers and be subject to the same provisions as an officer in-charge of a police station under section 436 of the Code of Criminal Procedure, 1973;

- (c) All arrest must be in accordance with the provisions of the Code of Criminal Procedure, 1973 relating to arrest.

Power to summon persons to give evidence and produce documents (Section 82)

Q 18. When can the proper officer issue summons?

Ans. Section 81 gives powers to a duly authorized CGST/SGST officer to call upon a person by issuing a summon to present himself before the officer issuing the summon to either give evidence or produce a document or any other thing in any inquiry which is being made by the officer is making. A summon to produce documents or other things may be for the production of certain specified documents or things or for the production of all documents or things of a certain description in the possession or under the control of the person summoned.

Q 19. What are the responsibilities of the person so summoned?

Ans. A person to whom a summon is issued legally bound to attend either in person or by an authorized representative and he is bound to state the truth before the officer who has issued the summon upon any subject, which is the subject matter of examination and to produce such documents and other things as may be required.

Access to business premises (Section 83)

Q 21. Can a CGST/SGST officer access business premises of a registered taxable person?

Ans. Yes. Access can also be obtained in terms of Section 83. This provision of law is meant to allow an audit party of CGST/SGST or a Cost Accountant or Chartered Accountant nominated under section 64, access to any business premises for the purposes of carrying out any audit, scrutiny, verification and checks as may be necessary to safeguard the interest of revenue. However, a written authorization is to be issued by an officer of the rank of Additional/Joint Commissioner of CGST or SGST. This provision facilitates access to any business premise of a taxable person where books of accounts, documents, computers, computer software etc. are kept which are required for audit or verification of accounts of a taxable person.

Officers required to assist CGST/SGST officers (Section 84)

Q 22. Are there any class of officers who are required to assist CGST/SGST officers?

Ans. Under section 84, the following officers have been empowered and are required to assist CGST/SGST officers in the execution this Act. The categories specified in Act are as follows:

- (a) Police

- (b) Customs
- (c) Officers of State/Central Government engaged in collection of GST
- (d) Officers of State/Central Government engaged in collection of land revenue
- (e) All village officers
- (f) Railways

Any other class of officers as may be notified by the Central/State Government

MCQ

Power of inspection, search and seizure (Section 79)

Q 1. Initiation of action under this section is by a CGST/SGST Officer not below the rank of

- (a) Superintendent
- (b) Inspector
- (c) Joint Commissioner
- (d) Commissioner

Ans. (c) *Joint Commissioner*

Q 2. Which are the places of business / premises which can be inspected by the CGST/SGST officer under this section?

- (a) Any places of business of a taxable person
- (b) Any places of business of a taxable person engaged in the business of transporting goods
- (c) Any places of business of an owner or an operator of a warehouse or godown
- (d) Any other place
- (e) All of the above

Ans. (e) *All of the above*

Q 3. Is it mandatory that 'reasons to believe' must exist before issuing authorization for Inspection or Search and Seizure by the proper officer?

- (a) Yes
- (b) No
- (c) None of the above

Ans. (a) *Yes*

- Q 4. Can the seized goods be released on provisional basis upon execution of a bond and furnishing of security or on payment of applicable tax, interest and penalty?
- (a) Yes
 - (b) No
 - (c) At proper officer's discretion
 - (d) None of the above

Ans. (a) Yes

Power to arrest (Section 81)

- Q 5. All arrests should be made as per the provisions of
- (a) Code of Criminal Procedure, 1973
 - (b) Civil Procedure Code
 - (c) Indian Penal Code
 - (d) Foreign Exchange Management Act

Ans. (a) Code of Criminal Procedure, 1973

Power to summon persons to give evidence and produce documents (Section 82)

- Q 6. When can the proper officer issue summons to call upon a person?
- (a) To give evidence
 - (b) Produce a document
 - (c) Produce any other thing in an enquiry
 - (d) All of the above

Ans. (d) All of the above

- Q 7. What can be the consequences of non-appearance to summons?
- (a) Prosecution under section 172, 174, 175 and 193 of the Indian Penal Code as the case may be
 - (e) Arrest under Code of Criminal Procedure, 1973
 - (b) Arrest under Foreign Exchange Management Act
 - (c) None of the above

Ans. (a) Prosecution under section 172, 174, 175 and 193 of the IPC as the case may be

Access to business premises (Section 83)

Q 8. The documents called for should be provided within.....

- (a) 20 days
- (b) 15 days
- (c) 5 days
- (d) 45 days

Ans. (b) 15 days

Officers required to assist CGST/SGST officers (Section 84)

Q 9. The Officer is empowered to assist the CGST/SGST officer.

- (a) Police/Customs
- (b) Health
- (c) CBI
- (d) State Excise

Ans. (a) Police/Customs

Chapter – XVIII

Offences and Penalties

FAQ

Offences and penalties (Section 85)

Q 1. Whether penalty is imposable for supply of goods or services without invoice or issue of invoice without supply of goods or services?

Ans. Yes, in terms of Section 85(1) (i) & (ii) supply of goods or services without invoice or issue of invoice without supply of goods or services are considered to be offences attracting penalty.

Q 2. I am collecting tax on supply of goods and services and did not remit the same within 3 months. Does the same attract penalty? If yes, what is the amount of penalty?

Ans. Collection of tax and non-remittance of the same within 3 months of due date for remittance is considered to be an offence under Section 85(1)(iii) attracting penalty of an amount equal to the tax so collected or ₹ 10,000/-,whichever is higher

Q 3. I have collected tax on supply of goods which are exempted from tax and did not remit the tax so collected to the Government account. Would I be liable to penal and other consequences?

Yes, collection of tax in contravention of the GST provisions and failure to pay the same to the credit of the appropriate Government beyond a period of three months from the date on which such payment becomes due is an offence attracting penalty of ₹ 10,000/- or amount equal to the amount of tax so collected, whichever is higher.

Further, in terms of Section 92(1), the said offence attracts imprisonment, which may extend from one year to five years based on the quantum of tax evasion.

Q 4. What are the other activities which would be considered to be offences attracting penalty?

Ans.

- (a) failure to deduct tax in terms of provisions of Section 46 or short deduction of tax or failure to remit tax so deducted
- (b) failure to collect tax by an E commerce operator in terms of Section 56 or short collection of tax or failure to remit tax so collected
- (c) taking or availment (or both) of input tax credit without actual receipt of goods or services in violation of the provisions

- (d) fraudulently obtaining refund of any CGST/SGST under this Act
- (e) takes or distributes input tax credit in violation of section 21, or the rules made thereunder;
- (f) falsifies or substitutes financial records or produces fake accounts and/or documents or furnishes any false information or return with an intention to evade payment of tax due under this Act;
- (g) failure to obtain registration even though liable to registration
- (h) furnishing of any false information with regard to registration particulars, either at the time of applying for registration, or subsequently;
- (i) Obstruction or prevention of any officer in discharge of his duties under the GST provisions;
- (j) Transports any taxable goods without the cover of documents
- (k) Suppression of turnover leading to evasion of tax under this Act;
- (l) Failure to keep, maintain or retain books of account and other documents in accordance with the provisions of this Act or the rules made there under;
- (m) Failure to furnish information and/or documents called for by a CGST/SGST officer in accordance with the provisions of this Act or rules made there under or furnishes false information and/or documents during any proceedings under this Act;
- (n) supplies, transports or stores any goods which he has reason to believe are liable to confiscation under this Act;
- (o) issues any invoice or document by using the identification number of another taxable person;
- (p) tampers with, or destroys any material evidence;
- (q) disposes off or tampers with any goods that have been detained, seized, or attached under this Act;

Q 5. What is the penalty that is imposable for the above referred offences?

Ans. ₹ 10,000/- or an amount equivalent to the tax evaded or the tax not deducted or short deducted or deducted but not paid to the Government or tax not collected under section 56 or short collected or collected but not paid to the Government or input tax credit availed of or passed on or distributed irregularly, or the refund claimed fraudulently, as the case may be, whichever is higher.

Q 6. Whether failure to pay tax or short payment of tax or where refund has been erroneously granted, would also attract penalty even though there is no fraud or misrepresentation or suppression of facts on the part of the taxable person?

Ans. Yes. In terms of Section 85(2), the non-payment of tax or short payment of tax or erroneous refund without intention to evade (i.e. not involving fraud or any wilful misstatement or suppression of facts to evade tax) would attract a penalty of ₹ 10,000/- or 10% of the tax due whichever is higher.

Q 7. Is there any penalty on the persons who aids or abets in offences attracting penalty in terms of Section 85(1)?

Ans. Yes, the said activity of aiding or abetting the offence would be an offence attracting a penalty to the extent of ₹ 25,000/-. Further, in terms of Section 85(3) following shall also be punishable offences:

- (a) acquires possession of, or in any way concerns himself in transporting, removing, depositing, keeping, concealing, supplying, or purchasing or in any other manner deals with any goods which he knows or has reason to believe are liable to confiscation under this Act or the rules made there under;
- (b) receives or is in any way concerned with the supply of, or in any other manner deals with any supply of services which he knows or has reason to believe are in contravention of any provisions of this Act or the rules made there under;
- (c) fails to appear before the CGST/SGST officer, when issued with a summon for appearance to give evidence or produce a document in an enquiry;
- (d) fails to issue invoice in accordance with the provisions of this Act or rules made there under, or fails to account for an invoice in his books of account

General Penalty (Section 86) or Power to impose penalty in certain cases (Section 88)

Q 8. Is there any provision prescribing penalty for contraventions of the provisions of the Revised Model GST Law or rules made there under?

Ans. Section 86 provides for general penalty which may extend to ₹ 25,000/- on any person, who contravenes any of the provisions of this Act or any rules made there under. This penalty would be applicable only where no penalty is separately provided for in this Act.

Further in terms of Section 88, where the proper officer is of the view that a person is liable to a penalty and the same is not covered under any proceeding under sections 59, 60, 61, 62, 66, 67, 89 or 90, he may issue an order levying such penalty after giving a notice and after giving a reasonable opportunity of being heard to such person.

General disciplines related to penalty (Section 87)

Q 9. When does the provisions of Section 87 (general discipline) apply?

Ans. In terms of Section 87(6) these provisions would not apply in such cases where the penalty prescribed under the Act is either a fixed sum or expressed as a fixed percentage

As most of the penal provisions except penalty under section 88 prescribe range of minimum and maximum penalties, a view could arise that the provisions of Section 87 would be applicable to determine amount of penalty between the said range.

Q 10. What are the general guidelines to be followed while imposing penalties?

Ans.

- Substantial penalties shall not be imposed for minor breaches of tax regulations or procedural requirements.
- No penalty in respect of any omission or mistake in documentation which is easily rectifiable and obviously made without fraudulent intent or gross negligence shall be greater than necessary to serve merely as a warning.
- The penalty imposed shall depend on the facts and circumstances of the case and shall commensurate with the degree and severity of the breach

Q 11. What are the acts which are considered as minor breach?

Ans. In terms of explanation to Section 87(1) following are considered as minor breach:

- (a) a breach shall be considered a 'minor breach' if the amount of tax involved is less than five thousand rupees.
- (b) an omission or mistake in documentation shall be considered to be easily rectifiable if the same is an error apparent on record.

Q 12. What are the procedures to be followed while imposing penalties?

Ans.

- Penalty shall not be imposed on any taxable person without giving a notice to show cause and without giving the person a reasonable opportunity of being heard.
- The tax authority shall ensure that when a penalty is imposed in an order for a breach of the laws, regulations or procedural requirements, an explanation is provided therein to the persons upon whom the penalty is imposed, specifying the nature of the breach and the applicable law, regulation or procedure under which the amount or range of penalty for the breach has been prescribed.

Q 13. Where a person voluntarily discloses information whether in such cases the same could be a factor to reduce the penalties?

Ans. In terms of Section 87(5) where a person voluntarily discloses to a tax authority the circumstances of a breach of the tax law, regulation or procedural requirement prior to the discovery of the breach by the tax authority, the tax authority may consider this fact as a potential mitigating factor when quantifying a penalty for that person.

Detention, seizure and release of goods and conveyances in transit (Section 89)

Q 14. Whether officer appointed under GST law has power to detain / seize the goods? When such detention or seizure could be undertaken?

Ans. Yes, seizure and detention of goods can be undertaken by the officer if any person transports any goods or stores any goods while they are in transit in contravention of the provisions of the GST Act or rules made thereunder,

Q 15. Under what circumstances the detained goods / conveyance or the documents seized could be released?

Ans. The goods/ conveyance / the documents could be released under the following circumstances:

- (a) on payment of the applicable tax and penalty equal to 100% of the tax payable on such goods, where the owner of the goods comes forward for payment of such tax and penalty;
- (b) on payment of the applicable tax and penalty equal to the fifty percent of the value of the goods reduced by the tax amount paid thereon, where the owner of the goods does not come forward for payment of such tax and penalty.
- (c) Notice is issued by proper officer specifying tax payable and order is passed by him for payment of tax and penalty

Q 16. What is the procedure to be followed for release of goods / conveyance or documents seized?

Ans. In order to release the goods / documents or conveyance the proper officer shall issue a notice specifying the tax payable and thereafter, pass an order for payment of tax and penalty as detailed above.

On payment of the amount referred to above, all liabilities under this section shall discharged in respect of goods and conveyance which were seized/detained.

Q 17. Is there any time limit within which the release could be sought?

Ans. Tax and penalty as prescribed in Section 89(1) shall be paid within 7 days of the date of detention to get the goods released.

Q 18. Is there any separate time limit for perishable goods?

Ans. Where the detained goods are perishable or hazardous in nature or are likely to depreciate in value with passage of time, the proper officer should reduce the said time period to period less than seven days.

Q 19. What are the consequences where the goods/ conveyance is not released?

Ans. Where owner or the person transporting the goods does not pay the amounts prescribed (tax plus penalty) and is unable to get the goods released within 7 days then in such cases, the provisions relating to confiscation of goods in terms of Section 90 read with provisions release of goods in terms of Section 79(6) would get attracted.

Confiscation of goods and/or conveyances and levy of penalty (Section 90)

Q 20. What are the circumstances under which the goods or conveyances could be confiscated?

Ans. Under following circumstances, goods / conveyance could be confiscated by the proper officer under GST provisions:

- (i) where a person supplies any goods in contravention of any of the provisions of this Act or rules made there under with intent to evade payment of tax; or
- (ii) where a person receives any goods in contravention of any of the provisions of this Act or rules made there under with intent to evade payment of tax; or
- (iii) where a person does not account for any goods on which he is liable to pay tax under this Act; or
- (iv) where a person supplies any goods which are liable to tax under this Act without having applied for registration; or
- (v) where a person contravenes any of the provisions of this Act or rules made there under with intent to evade payment of tax; or
- (vi) where a person uses any conveyance as a means of transport for carriage of taxable goods in contravention of the provisions of the Act or rules made there under unless the owner of the conveyance proves that it was so used without the knowledge or connivance of the owner himself, his agent, and the person in charge of the conveyance.

Q 21. Whether fine could be paid in lieu of confiscation and goods / conveyance be released?

Ans.

- The CGST/SGST officer adjudging the confiscation order shall give to the owner of the goods an option to pay a fine in lieu of confiscation. The fine shall

not exceed the market value of the goods confiscated, less the tax chargeable thereon

- where the owner is not known, such option could be given to the person from whose possession or custody such goods have been seized; or the owner or person in charge of conveyance
- The aggregate of such fine and penalty leviable shall not be less than the amount of penalty of 100% of the tax (if paid by owner) or 50% of the value of goods less tax (where it is paid by person other than owner in terms of Section 89(1))
- In case where conveyance is confiscated, and such conveyance is used for the carriage of the goods or passengers for hire, the owner of the conveyance shall be given an option to pay in lieu of the confiscation of the conveyance a fine equal to the tax payable on the goods being transported thereon.
- Where any fine in lieu of confiscation of goods or conveyance is imposed, the person (owner or other person) shall be liable to pay any tax and charges payable in respect of such goods in addition to the fine.

Q 22. What is the procedure to be followed for confiscation and for ordering payment of fine etc.?

Ans. Order of confiscation of goods and/or conveyance and/or imposition of penalty shall be made only after serving a notice on such person requiring him to show cause and by giving the person a reasonable opportunity of being heard.

Q 23. How should the officer handle the goods / conveyance confiscated?

- The title of goods and/or conveyance which are confiscated under this Act, shall vest in the appropriate Government.
- The proper officer adjudging confiscation shall take and hold possession of the things confiscated and every Officer of Police, on the requisition of such proper officer, shall assist him in taking and holding such possession.
- The proper officer may, after satisfying himself that the confiscated goods and conveyance are not required in any other proceedings under this Act and after giving reasonable time not exceeding three months to pay fine in lieu of confiscation, dispose such goods and/or conveyances and deposit the sale proceeds thereof with the Government.

Q 24. Whether prosecution or other punishments could also be initiated along with confiscation or penalty?

Ans. In terms of section 91 confiscation made or penalty imposed under the provisions of this Act or the rules made there under shall not prevent the infliction of any other

punishment to which the person affected thereby is liable under the provisions of this Act or under any other law.

MCQ

1. Which of the following would be an offence which is liable for penalty?
 - (a) supply of goods or services without invoice
 - (b) Issue of invoice without supply of goods and / or services
 - (c) Collects any amount as tax and not depositing the same beyond three months from the date of such collection.
 - (d) All of the above

Ans. (d) All of the above
2. Which of the following activities is not considered to be offence
 - (a) Failure to deduct tax in terms of provisions of Section 46 or short deduction of tax or failure to remit tax so deducted
 - (b) failure to collect tax by an E commerce operator in terms of Section 56 or short collection of tax or failure to remit tax so collected within
 - (c) non matching of input credit details with the invoice of the supplier because of error in filling the credit details
 - (d) fraudulently obtaining refund of any CGST/SGST under this Act

Ans. (c) non-matching of input credit details with the invoice of the supplier because of error in filling the credit details
3. What is the penalty that is imposable for falsifying the documents?
 - (a) Rupees Ten thousand
 - (b) Amount equivalent to tax evaded
 - (c) Lower of the (a) and (b) above
 - (d) Higher of the (a) and (b) above

Ans. (d) Higher of the (a) and (b) above
4. Mr.A short paid taxes because of error in computation of value of supplies. Whether any penalty would be liable to be paid?
 - (a) Rupees Ten thousands
 - (b) 10% amount equivalent to tax short paid
 - (c) Lower of the (a) and (b) above
 - (d) Higher of the (a) and (b) above

Ans. (d) Higher of the (a) and (b) above

5. What is the penalty that is imposable on person who aids or abets in offences attracting penalty in terms of Section 85(1)?
- (a) ₹ 25,000
 - (b) Amount equal to the tax evaded
 - (c) Though it is considered to be offence no penalty is prescribed
 - (d) It is not an offence at all

Ans. (a) ₹25,000

6. Which of the following shall also be punishable offences :
- (a) acquires possession of, or in any way concerns himself in transporting, removing, depositing, keeping, concealing, supplying, or purchasing or in any other manner deals with any goods which he knows or has reason to believe are liable to confiscation under this Act or the rules made thereunder;
 - (b) receives or is in any way concerned with the supply of, or in any other manner deals with any supply of services which he knows or has reason to believe are in contravention of any provisions of this Act or the rules made thereunder;
 - (c) fails to appear before the CGST/SGST officer, when issued with a summon for appearance to give evidence or produce a document in an enquiry;
 - (d) all of the above

Ans. (d) all of the above

7. Under what circumstances goods could be detained or seize by the proper office?
- (a) Where any person transports any goods in contravention of the provisions of the GST Act or rules made thereunder
 - (b) Storage of any goods while they are in-transit in contravention of the provisions of the GST Act or rules made thereunder,
 - (c) Both (a) and (b)
 - (d) None of the above

Ans. (c) Both (a) and (b)

8. Under what circumstances that detained goods / conveyance or the documents seized could be released by owner of the goods?
- (a) On payment of the applicable tax and penalty equal to 100% of the tax payable on such goods.
 - (b) On payment of applicable taxes along with interest and penalty equal to 10% of tax payable
 - (c) He cannot seek release of goods. Only transporter could seek
 - (d) None of the above

Ans. (a) on payment of the applicable tax and penalty equal to 100% of the tax payable on such goods.

9. Payment of amount and release of the seized goods could be sought within

- (a) Within 7 days of the date of detention of goods
- (b) Within 15 days of the date of detention of the goods
- (c) Within 30 days of the detention of the goods
- (d) None of the above

Ans. (a) Within 7 days of the date of detention of goods

10. What are the circumstances under which the goods or conveyances could be confiscated?

- (a) where a person supplies / or receives any goods in contravention of any of the provisions of this Act or rules made thereunder with intent to evade payment of tax;
- (b) where a person does not account for any goods on which he is liable to pay tax under this Act;
- (c) where a person supplies any goods which are liable to tax under this Act without having applied for registration;
- (d) all of the above

Ans. (d) all of the above

11. What is the fine that could be paid in lieu of confiscation?

- (a) The fine shall not exceed the market value of the goods confiscated, less tax chargeable on such goods
- (b) The fine shall not exceed 150% of the market value of the goods confiscated, less tax chargeable on such goods
- (c) The fine shall not exceed 50% of the market value of the goods confiscated, less tax chargeable on such goods
- (d) None of the above

Ans. (a) The fine shall not exceed the market value of the goods confiscated, less tax chargeable on such goods

12. Whether proper officer could dispose of the seized goods?

- (a) Yes, immediately after seizure he can dispose off the goods
- (b) No, he cannot dispose off the goods

- (c) Yes, after giving reasonable time not exceeding three months to pay fine in lieu of confiscation, dispose such goods and/or conveyances and deposit the sale proceeds thereof with the Government.
- (d) None of the above

Ans. (c) Yes, after giving reasonable time not exceeding three months to pay fine in lieu of confiscation, dispose such goods and/or conveyances and deposit the sale proceeds thereof with the Government.

13. Which of the following are true

- (a) confiscation or penalty under the provisions of this Act or the rules made thereunder shall not prevent the infliction of any other punishment this Act or under any other law.
- (b) Once goods are confiscated, no penalty could be imposed
- (c) On confiscation, penalty could be imposed but no other punishment could be inflicted.
- (d) None of the above

Ans. (a) confiscation or penalty under the provisions of this Act or the rules made thereunder shall not prevent the infliction of any other punishment this Act or under any other law.

14. What are the general guidelines to be followed while imposing penalties

- (a) Substantial penalties shall not be imposed for minor breaches of tax regulations or procedural requirements.
- (b) No penalty in respect of any omission or mistake in documentation which is easily rectifiable and obviously made without fraudulent intent or gross negligence shall be greater than necessary to serve merely as a warning.
- (c) The penalty imposed shall depend on the facts and circumstances of the case and shall commensurate with the degree and severity of the breach.
- (d) All of the above

Ans. (d) All of the above

15. Which of the following acts are not considered as minor breach

- (a) Where the amount of tax involved is less than five thousand rupees.
- (b) Where omission or mistake in documentation shall be considered to be easily rectifiable if the same is an error apparent on record.

- (c) Where the non-payment of tax is on account of procedural breach which involving fraud
- (d) None of the above

Ans. (c) Where the non-payment of tax is on account of procedural breach which involving fraud

16. Which of the following is not true?

- (a) Penalty shall not be imposed on any taxable person without giving a notice to show cause and without giving the person a reasonable opportunity of being heard.
- (b) The tax authority shall ensure that when a penalty is imposed in an order for a breach of the laws, regulations or procedural requirements, an explanation is provided therein to the persons upon whom the penalty is imposed, specifying the nature of the breach and the applicable law, regulation or procedure under which the amount or range of penalty for the breach has been prescribed.
- (c) where a person voluntarily discloses to a tax authority the circumstances of a breach of the tax law, the tax authority may consider this fact as a potential mitigating factor when quantifying a penalty for that person.
- (d) None of the above

Ans. (a) None of the above

17. When general penalty under GST law under section 86 could be imposed?

- (a) General penalty which may extend to ₹ 25,000/- on any person, who contravenes any of the provisions of this Act or any rules made thereunder.
- (b) This penalty would be applicable only where no penalty is separately provided for in this Act.
- (c) Both the above
- (d) None of the above

Ans. (c) Both the above

18. Which of the following is not a condition for imposing penalty under section 88?

- (a) Issue of notice proposing imposition of penalty
- (b) Giving reasonable opportunity of being heard to the person to whom the notice is issued.
- (c) Both of the above
- (d) None of the above

Ans. (d) None of the above

19. Which of the following are the offences which does not warrant prosecution?

- (a) Making a supply without issue of an invoice or grossly mis-declaring the description of the supply on invoice, in contravention of this Act, to intentionally evade tax ;
- (b) Issues any invoice or bill without supply in violation of the provisions of this Act/rules made thereunder leading to wrongful availment of credit or refund of duty
- (c) Collects any amount as tax but fails to pay the same to the credit of the appropriate Government beyond a period of three months from the date on which such payment becomes due
- (d) Delay in payment of tax on account of mismatch of credit

Ans. (d) Delay in payment of tax on account of mismatch of credit

20. Which of the following are the offences which does warrant prosecution on a person other than person liable to pay?

- (a) Obstruct or prevents any officer in the discharge of his duties or tampers with or destroys any material evidence or documents
- (b) Acquires possession of or transporting, removing, depositing, keeping, concealing, supplying, or purchasing or dealing in any other manner with any goods which he knows or has reason to believe are liable to confiscation under this Act or the rules made thereunder
- (c) Receives or deals with any supply of services which he knows or has reason to believe are in contravention of any provisions of this Act or the rules made thereunder
- (d) All of the above

Ans. (d) All of the above

21. What is the term of punishment for an offence involving tax evasion/ Wrong availment or utilisation of input tax credit/ Amount of Refund wrongly taken exceeding (₹250 lakh) two hundred and fifty lakh rupees

- (a) Five years imprisonment
- (b) one year imprisonment
- (c) Five years imprisonment with fine
- (d) one year imprisonment with fine

Ans. (c) Five years imprisonment with fine

22. Which of the following offences attracts punishment of Six months imprisonment with fine
- (a) Obstruction or prevention any officer in the discharge of his duties
 - (b) Tampering with or destroying any material evidence or documents
 - (c) Failing to supply any information required of him under the Act/Rules or supplying false information
 - (d) All of the above

Ans. (d) *All of the above*

23. What is the term of punishment where person is convicted of an offence for the second time and for every subsequent offence
- (a) Five years imprisonment
 - (b) Ten year imprisonment
 - (c) Five years imprisonment with fine
 - (d) Six years imprisonment with fine

Ans. (c) *five years imprisonment with fine*

24. Which of the following are non-cognizable and non-bailable offence
- (a) Making a supply without issue of any invoice or grossly mis-declares the description of the supply on invoice, in contravention of this Act, to intentionally evade tax
 - (b) Issues any invoice or bill without supply in violation of the provisions of this Act/rules made thereunder leading to wrongful availment of credit or refund of duty
 - (c) Collects any amount as tax but fails to pay the same to the credit of the appropriate Government beyond a period of three months from the date on which such payment becomes due
 - (d) Obstructs or prevents any officer in the discharge of his duties

Ans. (d) *Obstructs or prevents any officer in the discharge of his duties*

25. Is prior sanction of the designated authority compulsory for prosecution?
- (a) Yes. No person shall be prosecuted for any offence under this section without prior sanction of the competent authority
 - (b) No. but prior sanction may be required for offences involving non bailable offense
 - (c) None of the above
 - (d) Both (a) and (b) above

Ans. (a) *Yes. No person shall be prosecuted for any offence under this section without prior sanction of the competent authority*

Chapter - XIX

Prosecution and Compounding of Offences

FAQ

Prosecution (Section 92)

Q 1. Which are the offences which warrant prosecution?

Ans. Following offences attract prosecution:

1. Making a supply without issue of an invoice or grossly mis-declaring the description of the supply on invoice, in contravention of this Act, to intentionally evade tax ;
2. Issues any invoice or bill without supply in violation of the provisions of this Act/rules made thereunder leading to wrongful availment of credit or refund of duty
3. Collects any amount as tax but fails to pay the same to the credit of the appropriate Government beyond a period of three months from the date on which such payment becomes due
4. Collects any tax in contravention of the provisions of this Act but fails to pay the same to the credit of the appropriate government beyond a period of 3 months from the date on which such payment becomes due
5. Availing/utilizing input tax credit without actual receipt of goods and/or services either fully or partially in violation of the provisions of this Act or the rules made thereunder
6. Fraudulently avails input tax credit or evades tax or obtains refund
7. Falsification or substitution of financial records or producing fake accounts, documents or furnishes any false information with an intention to evade payment of tax
8. Obstruct or prevents any officer in the discharge of his duties
9. Acquires possession of, or in any way concerns himself in transporting, removing, depositing, keeping, concealing, supplying, or purchasing or dealing in any other manner with any goods which he knows or has reason to believe are liable to confiscation under this Act or the rules made thereunder
10. Receives or deals with any supply of services which he knows or has reason to believe are in contravention of any provisions of this Act or the rules made thereunder
11. Tampers with or destroys any material evidence or documents

12. Fails to supply any information which he is required to supply under this Act or the rules made thereunder or (unless with a reasonable belief, the burden of proving which shall be upon him, that the information supplied by him is true) supplies false information,
13. Attempts to commit or abets the commission of any of the offences mentioned above.

Q 2. What is the punishment prescribed on commission of offences, which warrant prosecution?

Offences	Punishment
Tax evaded / Wrong availment or utilisation of input tax credit / Amount of Refund wrongly taken exceeding (₹250 lakh) two hundred and fifty lakh rupees	Five years imprisonment with Fine
Tax evaded / Wrong availment or utilisation of input tax credit / Amount of Refund wrongly taken exceeding (₹ 100 Lakh) One hundred Lakh rupees but does not exceed (₹ 250 lakh) two hundred and fifty lakh rupees	Three years imprisonment with Fine
Tax evaded / Wrong availment or utilisation of input tax credit / Amount of Refund wrongly taken exceeding (₹ 50 Lakh) Fifty Lakh rupees but does not exceed (₹ 100 lakh) one hundred lakh rupees	One year imprisonment with Fine
Commits or abets in <ul style="list-style-type: none"> • Obstruction or prevention any officer in the discharge of his duties • Tampering with or destroying any material evidence or documents • Failing to supply any information required of him under the Act/Rules or supplying false information; 	Six months imprisonment with Fine

Q 3. What is the scenario if a person convicted for an offence under section 92 is again convicted of an offence under the same section?

Ans. The person shall be punishable for the second and for every subsequent offence with imprisonment for a term which may extend to five years and with fine.

Q 4. What are cognizable and non-cognizable offences?

Ans. In terms of Sec 92,

Cognizable/Non-bailable	Non-cognizable
<ul style="list-style-type: none"> • Making a supply without issue of any invoice or grossly mis-declares the description of the supply on invoice, in contravention of this Act, to intentionally evade tax • Issues any invoice or bill without supply in violation of the provisions of this Act/rules made thereunder leading to wrongful availment of credit or refund of duty • Collects any amount as tax but fails to pay the same to the credit of the appropriate Government beyond a period of three months from the date on which such payment becomes due • Collects any tax in contravention of the provisions of this Act but fails to pay the same to the credit of the appropriate government beyond a period of 3 months from the date on which such payment becomes due • Availing/utilizing input tax credit without actual receipt of goods and/or services either fully or partially in violation of the provisions of this Act or the rules made thereunder 	<p>All other offences specified under Sec 92 apart from those mentioned as cognizable/non bailable</p>
<p>Tax evaded or Wrong availment or utilisation of input tax credit or Amount of Refund wrongly taken exceeding (₹100 lakh) one hundred lakh rupees</p>	

Cognizable office is one where arrest by the police officer is permitted without warrant.

Q 5. Is prior sanction of the designated authority compulsory for prosecution?

Ans. Yes. No person shall be prosecuted for any offence under this section without prior sanction of the competent authority

Cognizance of offences (Section-93)

Q 6. Can inferior Courts take cognizance of any offence without prior sanction of the competent authority?

Ans. No Court shall take cognizance of any offence punishable except with the previous sanction of the designated authority, and no Court inferior to that of a Magistrate of the First Class, shall try any such offence.

Presumption of culpable mental state (Section-94)

Q 7. Is culpable mental state necessary for prosecution?

Ans. Yes. The Court shall presume the existence of culpable mental state but it shall be a defence for the accused to prove the fact that he had no such mental state with respect to the act charged as an offence in that prosecution.

Q 8. What constitutes Culpable mental state?

Ans. Culpable mental state includes

- (a) Intention
- (b) Motive
- (c) Knowledge of the fact
- (d) Belief in or reason to believe a fact

Q 9. When is a fact said to be proved under presumption of culpable mental state?

Ans. A fact is said to be proved only when the Court believes it to exist beyond reasonable doubt and not merely when its existence is established by a preponderance of probability.

Relevancy of statements under certain circumstances (Section 95)

Q 10. What is the relevance of the statements made and signed before the GST officers?

Ans. A statement made and signed by a person before any gazetted officer of CGST/IGST/SGST during the course of any inquiry or proceeding under this Act shall be relevant, for the purpose of proving, in any prosecution for an offence under this Act, the truth of the facts which it contains-

- (a) when the person who made the statement is dead or cannot be found, or is incapable of giving evidence, or is kept out of the way by the adverse party, or whose presence cannot be obtained without an amount of delay or expense which, under the circumstances of the case, the Court considers unreasonable;
or

- (b) when the person who made the statement is examined as a witness in the case before the Court and the Court is of the opinion that, having regard to the circumstances of the case, the statement should be admitted in evidence in the interests of justice.

Offences by Companies and certain other persons (Section 96)

Q 11. What are the consequences of offences committed by Companies and certain other persons?

Ans. Where an offence is committed by a company, every person who at the time of offence was committed was in charge of or was responsible to, the company for the conduct of business of the company as well as the company shall be deemed to be guilty of the offence and shall be liable to be prosecuted against and punished accordingly

Q 12. Whether director, manager, secretary or other officers of the Company can be punished for the offences committed by Companies and certain other persons wherein such offences were committed with the consent of any director, manager, secretary or other officers of the Company?

Ans. If offences committed by Companies and certain other persons is with the consent of any director, manager, secretary or other officers of the Company, then such director, manager, secretary or other officers of the Company shall also be deemed to be guilty of that offence and shall be liable to be proceeded against and punished accordingly in terms of Section 96.

Q 13. What are the consequences of offences committed by taxable person being a partnership firm or a LLP or HUF or a trust or the partner or Karta or managing trustee?

Ans. If offences are committed by taxable person being a partnership firm or a LLP or HUF or a trust or the partner or Karta or managing trustee, then such persons are also be deemed to be guilty of offence and shall be liable to be proceeded against and punished accordingly.

Q 14. What would be the situation if the person proves that the offence was committed without his knowledge or that he had exercised all due diligence to prevent the commission of such offence?

Ans. Such person shall not be liable to any punishment.

Compounding of offences (Section 97)

Q 15. Can offences under this Act be compounded?

Ans. Any offence under this Act be compounded by the competent authority on payment by the person accused of the offence to the Central Government or the State Government of such compounding amount in such manner as may be prescribed.

Q 16. What are the offences that cannot be compounded?

Ans. The following offences may not be compounded:

- A. A person who has been allowed to compound earlier in respect of any offences described as follows:
 - (i) Making a supply without issue of any invoice or grossly mis-declares the description of the supply on invoice, in contravention of this Act, to intentionally evade tax
 - (ii) Issues any invoice or bill without supply in violation of the provisions of this Act/rules made thereunder leading to wrongful availment of credit or refund of duty
 - (iii) Collects any amount as tax but fails to pay the same to the credit of the appropriate Government beyond a period of three months from the date on which such payment becomes due
 - (iv) Collects any tax in contravention of the provisions of this Act but fails to pay the same to the credit of the appropriate government beyond a period of 3 months from the date on which such payment becomes due
 - (v) Availing/utilizing input tax credit without actual receipt of goods and/or services either fully or partially in violation of the provisions of this Act or the rules made thereunder
 - (vi) Fraudulently avails input tax credit or evades tax or obtains refund
 - (vii) Falsification or substitution of financial records or producing fake accounts, documents or furnishes any false information with an intention to evade payment of tax
 - (viii) Attempts to commit or abets the commission of any of the offences mentioned above
- B. A person who has been allowed to compound earlier in respect of any offences described as above in clause (A) under this Act or under any provisions of any other SGST Act or IGST Act in relation to supplies of value exceeding one crore rupees
- C. Any offence which is also an offence under Narcotic Drugs & Psychotropic Substance Act, 1985 or Foreign Exchange Management Act, 1999 or any other Act other than CGST/SGST;
- D. A person who has been convicted for an offence under this act by a court
- E. A person who has been accused of committing an offence as under:
 - (i) Obstruct or prevents any officer in the discharge of his duties
 - (ii) Tamper with or destroys any material evidence or documents

- (iii) Fails to supply any information which he is required to supply under this Act or the rules made thereunder or (unless with a reasonable belief, the burden of proving which shall be upon him, that the information supplied by him is true) supplies false information.

Q 17. Is compounding of offence made before making payment of tax, interest and penalty involved in such offences?

Ans. No. Compounding shall be allowed only after making payment of tax, interest and penalty involved in such offences

Q 18. Are there any monetary limits prescribed for compounding of offence?

Ans. Yes. The minimum limit for compounding amount is to be the greater of the following amounts:-

- ₹ 10,000. or
- 50% of tax involved,

The upper limit for compounding amount is to be greater of the following amounts:-

- ₹ 30,000 or
- 150% of tax involved.

Q 19. What happens after the offence has been compounded?

Ans. On payment of such compounding amount, no further proceeding shall be initiated under the act against the accused person in respect of the same offence or any criminal proceedings if already initiated in respect of the said offence shall stand abated.

MCQ

Cognizance of offences (Section 93)

Q 1. Which Court could take cognizance of any offence?

- (a) Court Lower than that of Magistrate of the First Class
- (b) Magistrate of the First Class and Higher than that
- (c) High Court only
- (d) None of the above

Ans. (b) *Magistrate of the First Class and Higher than that*

- Q 2. Whether Court could take cognizance of offence without prior sanction of the competent authority?
- (a) Yes
 - (b) No.
 - (c) Yes, where the offences are not so serious offences
 - (d) None of the above

Ans. (b) No.

Presumption of culpable mental state (Section 94)

- Q 3. What constitutes culpable mental state?
- (a) Intention to commit an act
 - (b) Motive to commit an act
 - (c) Knowledge of the fact
 - (d) All of the above

Ans. (d) All of the above

Offences by Companies and certain other persons (Section 96)

- Q 4. Who could be prosecuted where the offence is committed by a Company?
- (a) Person who at the time of offence was in charge of the conduct of the business as well as those person who has consented to such offence
 - (b) Person who is authorized to sign the cheques
 - (c) Every officer whether or not connected with the offence
 - (d) All of the above

Ans. (a) Person who at the time of offence was in charge of the conduct of the business as well as those persons who has consented to such offence

- Q 5. When a person in charge of the business of a company shall not be punished
- (a) Where such person proves that the offence was committed without his knowledge
 - (b) that he had exercised all due diligence to prevent the commission of such offence
 - (c) both the above
 - (d) every person who is in charge is liable for punishment whether or not he has taken due care. Such person shall not be liable to any punishment.

Ans. (c) both the above

Compounding of offences (Section 97)

Q 6. Can offences under this Act be compounded?

- (a) Yes
- (b) No
- (c) Compounding is permissible only through sanction of the court
- (d) None of the above

Ans. (a) Yes

Q 7. Which of the following offences cannot be compounded?

- (a) person who has been allowed to compound earlier in respect of any offences described as above in clause (A) under this Act or under any provisions of any other SGST Act or IGST Act in relation to supplies of value exceeding one crore rupees
- (b) Any offence which is also an offence under Narcotic Drugs & Psychotropic Substance Act, 1985 or Foreign Exchange Management Act, 1999 or any other Act other than CGST/SGST;
- (c) A person who has been convicted for an offence under this act by a court
- (d) All of the above

Ans. (d) All of the above

Q 8. Which of the following is untrue?

- (a) On payment of such compounding amount, no further proceeding shall be initiated under the act against the accused person in respect of the same offence or any criminal proceedings if already initiated in respect of the said offence shall stand abated.
- (b) Only the tax proceedings shall deemed to be closed but the criminal proceedings would get continued.
- (c) None of the above

Ans. (a) *On payment of such compounding amount, no further proceeding shall be initiated under the act against the accused person in respect of the same offence or any criminal proceedings if already initiated in respect of the said offence shall stand abated.*

Chapter XX

Appeals and Revision

FAQ

Appeals to First Appellate Authority (Section 98)

Q 1. Whether provisions under GST Law provide for mechanism to contest the orders passed under this act?

Ans. Yes, section 98 of the GST Law provide for preferring an appeal against the order of the Adjudicating authority

Q 2. Who is an adjudicating authority?

Ans. Section 2(4) defines adjudicating authority to mean any authority competent to pass any order or decision under this Act. However, following are not covered under the ambit of adjudicating authority:

- (a) Board(Central Board of Customs and Excise),
- (b) Revisional Authority,
- (c) Authority for Advance Ruling,
- (d) Appellate Authority for Advance Ruling,
- (e) First Appellate Authority
- (f) Appellate Tribunal

Therefore, an order passed by any officer other than the Revisional Authority as well as other authorities mentioned above could be contested before the First Appellate Authority

Q 3. Who can prefer an appeal before the First Appellate Authority (“**FAA**”)?

Ans. Following can prefer an appeal before the First Appellate Authority:

- (a) Any person aggrieved by the order or decision of the adjudicating authority
- (b) Any GST officer on direction of the Commissioner (this is referred to as application)

Q 4. When a Commissioner direct the GST officer to prefer an appeal against the order of the adjudicating authority?

Ans. The Commissioner may, of his own motion, or upon request from the Commissioner of SGST/CGST call for and examine the record of any proceeding in which an

adjudicating authority has passed any decision or order under this Act for the purpose of satisfying himself as to the legality or propriety of the said decision or order and may, by order, direct any GST Officer subordinate to him to apply to the First Appellate Authority within six months from the date on which the said decision or order is communicated to such person for the determination of such points arising out of the said decision or order as may be specified by the Commissioner in his order.

Q 5. What is the time limit for filing appeal?

Ans. Appeal by a person aggrieved shall be filed within 3 months from the date of communication of the order. Whereas appeal filed by the department on the basis of the directions by the Commissioner shall have to be filed within 6 months from date of communication of the decision or order.

Q 6. Whether appeal filed beyond 3 months / 6 months' time limit would be entertained?

Ans. FAA has been conferred with powers to condone the delay beyond the period of 3 months or 6 months, upto a period of 1 month where sufficient cause for the delay is shown.

Q 7. Whether entire amount of tax, interest, penalty, fine or fee has to be remitted before preferring appeal?

Ans. No. For filing appeal following amounts shall have to be remitted as pre-deposit.

- (a) Where any part of the amount of tax, interest, fine, fee and penalty arising from the impugned order, as is admitted by him, entire such amount and
- (b) a sum equal to 10% of the remaining amount of tax in dispute arising from the said order, in relation to which the appeal has been filed shall be paid

Q 8. Whether department could insist on payment of higher amount of pre-deposit

Ans. Yes. Proviso section 98(6) provides the right to the departmental authorities to apply to the First Appellate Authority for ordering a higher amount of pre-deposit, not exceeding twenty five percent of the amount of tax in dispute, in a case which is considered by the Commissioner of GST to be a "serious case".

For the purpose of this proviso, the expression "serious case" shall mean a case in which an order has been passed under section 67 involving a disputed tax liability of not less than Rupees Twenty-Five Crores.

Q 9. Is it mandatory on the part of FAA to provide opportunity where there is an insistence on payment of higher amount of pre-deposit?

Ans. In terms of section 98(7) the FAA shall give an opportunity to the appellant, if he so desires. Therefore, the appellant has to expressly state that he requires an opportunity of being heard.

However, in term of proviso to Section 98(10) an order enhancing any fee or penalty or fine in lieu of confiscation or confiscating goods of greater value or reducing the amount of refund or input tax credit shall not be passed unless the appellant has been given a reasonable opportunity of showing cause against the proposed order

Q 10. Whether parties to an appeal could seek adjournment of the hearing?

Ans. The FAA may, if sufficient cause is shown at any stage of hearing of an appeal, grant time, from time to time, to the parties or any of them and adjourn the hearing of the appeal for reasons to be recorded in writing. However, no such adjournment shall be granted more than three times to a party during hearing of the appeal.

Q 11. Could a new ground, which was not part of the grounds of appeal, could be taken up before FAA?

Ans. The FAA at the time of hearing of an appeal, may allow an appellant to go into any ground of appeal not specified in the grounds of appeal, if he is satisfied that the omission of that ground from the grounds of appeal was not willful or unreasonable.

Q 12. What type of order could the FAA pass?

Ans. The FAA may pass such order, as he thinks just and proper, confirming, modifying or annulling the decision or order appealed against. The order shall be in writing giving details as to determination, the reasons there on and the reasons for decision

Q 13. Whether the FAA can refer case back to the adjudicating authority

Ans. The FAA does not have power to refer the case back to the authority that passed the said decision or order.

Revisional powers of Chief Commissioner or Commissioner (Section 99)

Q 14. Which officer is vested with the power to review the orders or decisions of lower authority?

Ans. Chief Commissioner or Commissioner [review authority] has been vested with the power to review the orders or decisions of lower authority

Q 15. Under what circumstances revisionary powers can be invoked?

Ans. The review authority either on his own motion or based on the information received by him or based on the request of the Commissioner could call for and examine the record of any proceeding, and if he considers that any decision or order passed under this Act or under the [SGST/CGST] Act as authorized under section 7 of the [SGST/CGST] Act by any officer subordinate to him, where

- (a) such order is erroneous in so far as it is prejudicial to the interest of the revenue and

- (b) such order is illegal or improper or has not taken into account certain material facts, whether available at the time of issuance of the said order or not
- (c) in consequence of an observation by the Comptroller and Auditor General of India,

For the purposes of this section, 'decision' shall include intimation given by any officer lower in rank than the Chief Commissioner or, as the case may be Commissioner.

For the purposes of this section, 'record' shall include all records relating to any proceedings under this Act available at the time of examination by the Chief Commissioner or Commissioner.

Q 16. Whether order of FAA could also be reviewed by review authority?

Ans. The order which has been subject to an appeal under before FAA (section 98) as well as orders of FAA which are appealed before Tribunal cannot be reviewed by Review authority. However, review authority could pass an order under revisionary power on any point which has not been raised and decided in an appeal before FAA. Such revision order could be passed within 1 year from the date of the order of FAA or 3 years from the date of the original order whichever is later.

Q 17. What are the other orders or decision review authority cannot review?

Ans. Following orders or decisions cannot be reviewed by a revision authority

- (a) orders or decisions set out in section 112 against which no appeal could be preferred
- (b) order has been subject to an appeal under before Tribunal (under section 101) or High Court (under section 106) or Supreme Court (under section 107); or
- (c) the period of 6 months as specified under 98(2) for preferring an appeal by department before FAA has not yet expired or
- (d) where more than three years have expired after the passing of the decision or order sought to be revised.
- (e) Where the order has already been taken for revision under this section at any earlier stage.

Q 18. What are the orders that could be passed by the review authority in review?

Ans. Review authority, may if necessary, stay the operation of the order sought to be reviewed. Further, after making such further inquiry as may be necessary, pass such order, as he thinks just and proper, including enhancing or modifying or annulling the said decision or order.

Q 19. Whether the assessee be given an opportunity of being heard before making the orders by review authority?

Ans. Yes, the person concerned with the order that is the subject matter of the review shall be given an opportunity of being heard.

Q 20. Whether appeal could be preferred against the order of the review authority?

Ans. Yes. In terms of Section 99(4) every order passed in revision shall, subject to the provisions of sections 102, 106 or 107, be final. Appeal against the revision orders could be preferred before the Hon'ble Tribunal

Q 21. How to compute the time limit of 3 years (from the date of the order of lower authority) / 1 year within which the order shall be reviewed

Ans. Where the said decision or order involves an issue on which the Appellate Tribunal or the High Court has given its decision which is prejudicial to the interest of revenue in some other proceedings and an appeal to the High Court or the Supreme Court against such decision of the Appellate Tribunal or as the case maybe, the High Court is pending, the time period spent between the date of the decision of the Appellate Tribunal and the date of the decision of the High Court or as the case may be, the date of the decision of the High Court and the date of the decision of the Supreme Court shall be excluded in computing the period of 3 years, where notice for revision has been issued.

Where the issuance of an order under section 99(1) is stayed by the order of a Court or Tribunal, the period of such stay shall be excluded in computing the period referred to in section 99(2)(b).

National Appellate Tribunal (Section100)

Q 22. What is the Constitution of National Appellate Tribunal and how the same is constituted?

Ans. The Central Government shall on the recommendation of the GST Council constitute a National Goods and Services Tax Appellate Tribunal (hereinafter referred to as the Appellate Tribunal. The Appellate Tribunal shall be headed by a National President [Section100 (1) & (2)].

Q 23. What is State GST Tribunal?

Ans. The Appellate Tribunal shall have one branch for each State, which shall be called as the State GST Tribunal. Every State GST Tribunal will be headed by a State President. [Section 100(3) & (4)]

Q 24. What is the structure of State GST Tribunal?

Ans. Every State GST Tribunal shall consist of as many Members (Judicial), Members (Technical - CGST) and Members (Technical - SGST) as may be prescribed, to exercise the powers and discharge the functions conferred on the Appellate Tribunal by this Act.

The qualifications, eligibility conditions and the manner of selection and appointment of the National President, Members (Judicial) and the Member (Technical-CGST) shall be such as may be prescribed by the Central Government on the recommendations of the Council.

The qualifications, eligibility conditions and the manner of selection and appointment of the State Presidents and the Members (Technical-SGST) shall be such as may be prescribed by the State Government, on the recommendations of the Council. [Section 100 (5) to (7)]

Q 25. What are the powers of National president and State president?

Ans. The National President and the State Presidents shall exercise such powers and discharge such functions as may be prescribed on the recommendations of the Council. On ceasing to hold office, the National President, the State Presidents or other Members of the Appellate Tribunal shall not be entitled to appear, act or plead before the Appellate Tribunal.

Appeals to the Appellate Tribunal (Section 101 to 105)

Q 26. Who could prefer an appeal before the Tribunal and against which orders an appeal could be preferred?

Ans. Any person aggrieved by the order of the FAA or order of the review authority could prefer an appeal before the Appellate Tribunal (Tribunal).

Q 27. Is there any monetary limits based on which appeals could be rejected?

Ans. The Tribunal has been conferred with discretion to refuse to admit an appeal where the tax or input tax credit involved or the difference in tax or input tax credit involved or the amount of fine, fee or penalty determined by such order, does not exceed ₹ 1,00,000/-

Q 28. Whether the Department could also file appeal to Tribunal against the orders of FAA or review authority?

Ans. Yes department could also prefer an appeal before the Tribunal. The procedure is detailed below:

- The Commissioner by an order, constitute such Committees consisting of two officers as may be necessary for the purposes of review of and filing appeals against the orders passed by FAA or by Review authority
- The Committee may, if it is of the opinion that an order passed by FAA or by the review authority is not legal or proper, direct any officer authorized by it in this behalf to apply to the Appellate Tribunal within six months from the date on which the order sought to be appealed against is communicated to the Commissioner for the determination of such points arising out of the said order as may be specified by the Committee:

- Where the Committee differs in its opinion, it shall be deemed that the Committee has formed the opinion that the order under review is not legal or proper.
- Where in terms of the above an application is made to the Tribunal, such application shall be dealt with by the Tribunal in a manner similar to the appeal preferred by the party

Q 29. Whether other party could file cross objections against the appeal preferred by the assessee or by the department?

Ans. On receipt the appeal the other party could prefer a cross objection to the appeal even though he has not preferred an appeal. Cross objection shall have to be filed within 45 days from the date of receipt of the notice of appeal. The Tribunal shall dispose of the cross objections as if it is an appeal

Q 30. What is the time limit for filing appeal / cross objections?

Ans. The time limit is as under

Appeal by Assessee	3 months from the date of receipt of the order against which the appeal is being preferred
Application by Department	6 months from the date of receipt of the order against which the application is being preferred
Cross objections	45 days from the date of receipt of notice of appeal

Q 31. Whether appeal / application / cross objections filed beyond the time limit would be entertained?

Ans. Tribunal has been conferred with powers to condone the delay beyond the period of 3 months or 6 months, 45 days where sufficient cause for the delay is shown.

Q 32. Whether entire amount of tax, interest, penalty, fine or fee has to be remitted before preferring appeal?

Ans. No. For filing appeal following amounts shall have to be remitted as pre-deposit.

- Where any part of the amount of tax, interest, fine, fee and penalty arising from the impugned order, as is admitted by him, such entire amount and
- A sum equal to 10% of the remaining amount of tax in dispute arising from the said order, in relation to which the appeal has been filed shall be paid. This amount (10%) is in addition to the pre-deposit paid while filing appeal before FAA.

- (c) Requirement of pre-deposit would also be applicable to the cross objections filed.

Q 33. Whether department could insist on payment of higher amount of pre-deposit

Ans. Yes. Proviso section 101(9) provides the right to the departmental authorities to apply to the Tribunal for ordering a higher amount of pre-deposit, not exceeding twenty five percent of the amount of tax in dispute, in a case which is considered by the Commissioner of GST to be a "serious case".

For the purpose of this proviso, the expression "serious case" shall mean a case in which an order has been passed under section 67 involving a disputed tax liability of not less than Rupees Twenty-Five Cores.

Q 34. Whether parties to an appeal could seek adjournment of the hearing?

Ans. The Tribunal may, if sufficient cause is shown at any stage of hearing of an appeal, grant time, from time to time, to the parties or any of them and adjourn the hearing of the appeal for reasons to be recorded in writing. However, no such adjournment shall be granted more than three times to a party during hearing of the appeal.

Q 35. Whether Tribunal has power to rectify / amend the orders passed by it?

Ans. Yes, Tribunal may amend any order passed by it under in terms of Section 102(1) so as to rectify any mistake apparent from the record. Tribunal could undertake rectification on its own or on application by either of the parties to the appeal. The application for rectification shall be made within a period of three months from the date of the order sought to be rectified.

However, no amendment which has the effect of enhancing an assessment or reducing a refund or input tax credit or otherwise increasing the liability of the other party, shall be made under this sub-section, unless the Tribunal has given notice of its intention to do so and has allowed a reasonable opportunity of being heard.

Q 36. What shall be the composition of bench of the Tribunal?

Ans. Bench shall consist of one Member (Judicial), one Member (Technical - CGST) and one Member (Technical - SGST).

Q 37. What type of cases a member of the Tribunal decide sitting singly?

Ans. Member of the Tribunal sitting singly, may dispose of any case which has been allotted to the Bench of which he is a member, wherein any disputed case, the tax or input tax credit involved or the difference in tax or input tax credit involved or the amount of fine, fee or penalty involved, does not exceed ₹ 10 Lakhs.

Q 38. Where an assessee gets a favourable decision either before FAA or the Tribunal, whether the pre-deposit would be refunded back? Whether any interest is paid?

Ans. Yes, where the assessee gets a favorable decision (fully or partially), the amount paid as pre-deposit would be refunded along with interest at the rate specified under section 50, which is computed from the date of deposit till date of refund.

Q 39. Who could represent before GST officer of FAA or the Tribunal?

Ans. Following persons could act an authorized representative and appeal before the officer or FAA or the Tribunal on behalf of an assessee

- (a) relative or regular employee of the assessee; or
- (b) an advocate who is entitled to practice in any court in India, and who has not been debarred from practicing before any court in India; or
- (c) any chartered accountant, a cost accountant or a company secretary, who holds a valid certificate of practice and who has not been debarred from practice; or
- (d) a retired officer of the Commercial Tax Department of any State Government or of the Central Board of Excise and Customs, Department of Revenue, Government of India, who, during his service under the Government, had worked in a post not lower in rank than that of a Group-B gazetted officer for a period of not less than two years.
- (e) any person who has been authorized to act as a Tax Return Preparer on behalf of the concerned registered taxable person.

However, no person who was serving in the indirect tax departments of the Government of India or of any State Government, and has retired or resigned from such service after having served for not less than two years as a gazetted officer in that department shall be entitled to appear as an authorised representative in any proceedings before a GST Officer for a period of one year from the date of his retirement or resignation, as the case may be.

Appeal to the High Court (Section 106)

Q 40. What is the time limit within which appeal could be preferred before High Court?

Ans. Appeal before High Court shall be filed within 180 days from the date on which the order appealed against is received by the Commissioner of GST or the other party

Q 41. Whether High Court could admit the appeal filed beyond 180 days?

Yes. Where the High Court is satisfied that that there was sufficient cause for not filing the appeal within that period, it may condone the delay.

Q 42. Whether a question involving factual disputes could be taken up before High Court?

Ans. Appeal before High Court would be preferable only where the High court is satisfied that the case involves a substantial question of law.

Q 43. What are the matters on which the appeal against order of the Tribunal cannot be preferred before High Court?

Ans. No appeal shall lie to High Court against an order passed by the Tribunal if such order relates among other things to:

- (a) a matter where two or more States, or a State and Center, have a difference of views regarding the treatment of a transaction(s) being intra-State or inter-State; or
- (b) a matter where two or more States, or a State and Center, have a difference of views regarding place of supply.

Q 44. Whether High Court could determine an issue which has not been determined by the Tribunal?

Ans. Yes. The High Court may determine any issue which has not been determined by the Appellate Tribunal. Further, High Court may also determine any issue which has been wrongly determined by the Appellate Tribunal, by reason of a decision on such question of law.

Q 45. Whether the appeal could be decided by a judge sitting singly?

Ans. No. Appeal filed before the High Court, shall be heard by a bench of not less than two Judges of the High Court, and shall be decided in accordance with the opinion of such Judges or of the majority, if any, of such Judges.

Where there is no such majority, the Judges shall state the point of law upon which they differ and the case shall, then, be heard upon that point only, by one or more of the other Judges of the High Court and such point shall be decided according to the opinion of the majority of the Judges who have heard the case including those who first heard it.

Q 46. Whether amounts confirmed in terms of the order to be remitted even though appeal is preferred before High Court or Supreme Court?

Ans. Yes. Not with standing that an appeal has been preferred to the High Court or the Supreme Court, sums due to the Government as a result of an order passed by the Tribunal or an order passed by the High Court, as the case may be, shall be payable in accordance with the order so passed.

Appeal to the Supreme Court (Section 107)

Q 47. When an appeal could be preferred before the Supreme Court

Ans. Under the following circumstances appeal could be preferred before the Supreme Court

- 1. Against the Order of the High Court
- 2. Against the Order of the Tribunal

where

- (a) a matter where two or more States, or a State and Center, have a difference of views regarding the treatment of a transaction(s) being intra-State or inter-State; or
- (b) a matter where two or more States, or a State and Center, have a difference of views regarding place of supply.

Q 48. Whether all the orders of the High Court could be challenged before the Supreme Court?

Ans. No only against the judgment or order, where the High Court certifies to be a fit one for appeal to the Supreme

Hearing before Supreme Court (Section 108)

Q 49. What is the procedure to be followed for hearing before the Supreme Court?

Ans.

- (a) The provisions of the Code of Civil Procedure, 1908, relating to appeals to the Supreme Court, so far as they apply in the case of appeals from decrees of a High Court would be applicable to the appeals under this act also
- (b) The costs of the appeal shall be at the discretion of the Supreme Court.
- (c) Where the judgment of the High Court is varied or reversed in the appeal, effect shall be given to the order of the Supreme Court in the manner provided in section 106 in the case of a judgment of the High Court.

Non Appealable Decisions and Orders (Section-112)

Q 50. Whether all orders or the officer of GST could be appealed with First Appellate authority or the Tribunal as the case may be?

Ans. No. in terms of Section 112, orders listed below cannot be appeal against. Therefore, except such order, appeal could be preferred against all other orders:

- (a) An order of the Commissioner or other competent authority for transfer of proceeding from one officer to another officer; or
- (b) An order pertaining to the seizure or retention of books of account, register and other documents; or
- (c) An order sanctioning prosecution under the Act; or
- (d) An order under section 74 allowing an assessee to pay tax and other amounts adjudicated in installments.

MCQ**Appeals to First Appellate Authority (Section 98)**

1. Who could prefer an appeal before First Appellate Authority?
 - (a) Any person aggrieved by any decision or order passed under this Act by an adjudicating authority.
 - (b) Only GST authority could prefer
 - (c) Only the assessee could prefer
 - (d) Only by a person liable to pay tax or penalty

Ans. (a) Any person aggrieved by any decision or order passed under this Act by an adjudicating authority.
2. Against which of the following orders no appeal could be preferred before FAA
 - (a) Orders passed by any officer other than the revisionary authority
 - (b) Orders passed by Assistant commissioner of GST
 - (c) Both of the above
 - (d) None of the above

Ans. (a) Orders passed by any officer other than the revisionary authority
3. What is the time limit within which the appeal before FAA shall be filed by the assessee?
 - (a) Within three months of date of passing of the order
 - (b) Within three months of date of dispatch of the order by the department
 - (c) Within three months of date of communication of the order to the assessee
 - (d) Within three months from the date of receipt of the order by the authorized signatory for the appeal

Ans. (c) Within three months of date of communication of the order to the assessee
4. Whether First Appellate authority could condone the delay in filing the appeal? If so what is the period of delay he may condone?
 - (a) No, no condonation of delay is permitted
 - (b) Yes, he could condone the delay without any limit
 - (c) Yes he could condone the delay upto the period of 3 months
 - (d) Yes he could condone the delay upto the period of 1 month

Ans. (d) Yes he could condone the delay upto the period of 1 month

5. Could a new ground, which was not part of the grounds of appeal, could be taken up before FAA?
- (a) No
 - (b) Yes, First Appellate authority is bound to allow
 - (c) Yes, First Appellate authority is provided with discretion to allow if he is satisfied that omission was not willful or unreasonable
 - (d) None of the above

Ans. (c) Yes, First Appellate authority is provided with discretion to allow if he is satisfied that omission was not willful or unreasonable

Revisional powers of Chief Commissioner or Commissioner (Sec 99)

6. Under what circumstances orders of the lower authorities could be reviewed by the revisionary authority?
- (a) Where such order is erroneous in so far as it is prejudicial to the interest of the revenue
 - (b) Where such order is illegal or improper or has not taken into account certain material facts, whether available at the time of issuance of the said order or not
 - (c) in consequence of an observation by the Comptroller and Auditor General of India,
 - (d) All of the above

Ans. (d) All of the above

7. Which are the other orders or decisions, that a review authority cannot review?
- (a) Orders or decisions set out in section 112 against which no appeal could be preferred
 - (b) Order has been subject to an appeal under before Tribunal (under section 101) or High Court (under section 106) or Supreme Court (under section 107); or
 - (c) The period of 6 months as specified under 98(2) for preferring an appeal by department before FAA has not yet expired or
 - (d) Where more than three years have expired after the passing of the decision or order sought to be revised.
 - (e) All of the above

Ans. (e) All of the above

8. Whether the assessee be given opportunity of being heard before making the orders by review authority?

- (a) No, since it is a revision of the order by the department itself, no such requirement is there
- (b) Yes, only where the assessee has sought personal hearing before the adjudicating authority
- (c) Yes, the person concerned with the order that is the subject matter of the review shall be given an opportunity of being heard
- (d) None of the above

Ans. (c) Yes, the person concerned with the order that is the subject matter of the review shall be given an opportunity of being heard

National Appellate Tribunal (Section 100)

9. The National Appellate Tribunal will be headed by -
- (a) State President
 - (b) Senior Member of all the members
 - (c) National President
 - (d) None of the above

Ans. (c) National President

10. On ceasing to hold office by Members of Tribunal, they are –
- (a) Permitted to appear before Tribunal
 - (b) Permitted to appear before Tribunal only after 3 years
 - (c) Not permitted to appear before Tribunal
 - (d) None of the above

Ans. (c) Not permitted to appear before Tribunal

Appeal to the Appellate Tribunal (Section 101); Orders of Appellate Tribunal (Section 102); Procedure of Appellate Tribunal (Section 103); Interest on refund of pre-deposit (Section 104) and Appearance by authorised representative (Section 105)

11. Which are the order against which appeal could be preferred before the Appellate Tribunal
- (a) Order of the First appellate authority
 - (b) Order of the revision authority could

(c) Both (a) and (b) above

(d) None of the above

Ans. (c) Both (a) and (b) above

12. Whether the Tribunal could refuse to admit an appeal based on monetary limits?

(a) No such powers are conferred with the Tribunal

(b) Yes. But only in case of the appeals filed by the department

(c) Yes. Any appeal where the tax or input tax credit involved or the difference in tax or input tax credit involved or the amount of fine, fee or penalty determined by such order, does not exceed ₹ 1,00,000/-

(d) None of the above

Ans. (d) Yes. Any appeal where the tax or input tax credit involved or the difference in tax or input tax credit involved or the amount of fine, fee or penalty determined by such order, does not exceed ₹ 1,00,000/-

13. Whether other party could file cross objections against the appeal preferred by the assessee or by the department?

(a) No

(b) Yes. But only the department could file

(c) Yes. Both department as well as assessee could file

(d) None of the above

Ans. (c) Yes. Both department as well as assessee could file

14. Appeal before the Tribunal shall be filed by the assessee within

(a) 3 months from the date of the order

(b) 3 months from the date of payment of pre-deposit

(c) 3 months from the date of receipt of the order against which the appeal is being preferred

(d) None of the above

Ans. (c) 3 months from the date of receipt of the order against which the appeal is being preferred

15. Is there any time limit to file cross objections?

(a) No time limit is prescribed

(b) Within 3 months from the date of the filing of the appeal

- (c) Within 45 days from the date of receipt of notice of filing of appeal
- (d) None of the above

Ans. (c) Within 45 days from the date of receipt of notice of filing of appeal

16. Whether appeal / application / cross objections filed beyond the time limit would be entertained?

- (a) Tribunal has been conferred with powers to condone the delay without any time limit
- (b) Tribunal does not have powers to condone the delay
- (c) Tribunal could condone the delay upto 3 months
- (d) None of the above

Ans. (a) Tribunal has been conferred with powers to condone the delay without any time limit

17. What is the pre-deposit to be remitted before preferring appeal?

- (a) Where any part of the amount of tax, interest, fine, fee and penalty arising from the impugned order, as is admitted by him, entire such amount;
- (b) a sum equal to 10% of the remaining amount of tax in dispute arising from the said order, in relation to which the appeal has been filed shall be paid. This amount (10%) is in addition to the pre-deposit paid while filing appeal before FAA.
- (c) Both (a) and (b) above
- (d) Entire amount of tax to be paid

Ans. (c) Both (a) and (b) above

18. Whether pre-deposit is refundable where the assessee wins the case?

- (a) No refund is permitted. Same would be forfeited
- (b) Yes. Only where the Tribunal specifically mentions so in its order
- (c) Yes. Whether or not the tribunal mentions about the same in its order
- (d) None of the above

Ans. (c) Yes. Whether or not the tribunal mentions about the same in its order

19. Whether Tribunal has power to rectify / amend the orders passed by it?

- (a) No. The Tribunal is not conferred with power to rectify or amend its own orders.
- (b) Yes. Only under the directions of the High Court
- (c) Yes, Tribunal may amend any order passed by it, so as to rectify any mistake

apparent from the record on its own or on the basis of the application by the parties

(d) None of the above

Ans. (c) Yes, Tribunal may amend any order passed by it, so as to rectify any mistake apparent from the record on its own or on the basis of the application by the parties

20. What shall be the composition of bench of the Tribunal?

(a) Bench shall consist of 3 members [one Member (Judicial), one Member (Technical - CGST) and one Member (Technical - SGST)]

(b) Bench shall consists of 3 members [Two Members (Judicial) and one Member (Technical - CGST)]

(c) Bench shall consists of 3 members [President, one Member (Technical - CGST) and one Member (Judicial)]

(d) None of the above

Ans. (a) Bench shall consist of 3 members [one Member (Judicial), one Member (Technical - CGST) and one Member (Technical - SGST)]

21. What type of cases a member of the Tribunal decide sitting singly?

(a) Any case which has been allotted to the Bench of which he is any member (including the president) , wherein any disputed case, the tax or input tax credit involved or the difference in tax or input tax credit involved or the amount of fine, fee or penalty involved, does not exceed ₹ 10 Lakhs

(b) No cases could be disposed off singly by the Tribunal

(c) Only President could dispose off the cases sitting singly

(d) None of the above

Ans. (a) Any case which has been allotted to the Bench of which he is any member (including the president) , wherein any disputed case, the tax or input tax credit involved or the difference in tax or input tax credit involved or the amount of fine, fee or penalty involved, does not exceed ₹ 10 Lakhs

22. Who could represent before GST officer of FAA or the Tribunal

(a) relative or regular employee of the assessee;

(b) an advocate who is entitled to practice in any court in India, and who has not been debarred from practicing before any court in India;

(c) any chartered accountant, a cost accountant or a company secretary, who holds a valid certificate of practice and who has not been debarred from practice; or

(d) all of the above

Ans. (d) all of the above

23. Whether the Tribunal could refer case back to the Original adjudicating authority
- (a) No. the Tribunal has no power to refer the case back to any authority
 - (b) No. the Tribunal can only refer back the case to First Appellate authority not to adjudicating authority
 - (c) Yes. The Tribunal could refer back the case to First appellate authority or adjudicating authority or revisionary authority
 - (d) None of the above
- Ans. (c) Yes. *The Tribunal could refer back the case to First appellate authority or adjudicating authority or revisionary authority*

Appeal to the High Court (Section 106)

24. What is the time limit within which appeal could be preferred before High Court?
- (a) 1 year from the date of the order of the Tribunal
 - (b) 180 days from the date on which the order appealed against is received
 - (c) 240 days from the date on which the order appealed against is received
 - (d) No time limit
 - (e) Appeal before High Court shall be filed within 180 days from the date on which the order appealed against is received by the Commissioner of GST or the other party
- Ans. (b) *180 days from the date on which the order appealed against is received*
25. Whether every order of the Tribunal could be contested before the High Court
- (a) Yes, every order could be contested.
 - (b) No. Appeal before High Court would be preferable only where the High court is satisfied that the case involves a substantial question of law
 - (c) No. only where the amount of tax involved is more than Rupees One crore
 - (d) None of the above
- Ans. (d) *none of the above-issues not involving substantial question, a) a matter where two or more States, or a State and Center, have a difference of views regarding the treatment of a transaction(s) being intra-State or inter- State) a matter where two or more States, or a State and Center, have a difference of views regarding place of supply, cannot be appealed before High court*
26. Appeal relating to GST before High Court shall be heard by
- (a) Single Judge
 - (b) Two Judges
 - (c) Three judges
 - (d) Five Judges
- Ans. (b) *Two judges*

27. When shall an appeal be preferred before the Supreme Court under GST law?
- (a) Against an orders of the High Court which High Court certifies to be a fit one for appeal to the Supreme Court
 - (b) any order passed by the Appellate Tribunal under section 102 where such order is of the nature a matter where two or more States, or a State and Center, have a difference of views regarding place of supply
 - (c) Both the above
 - (d) None of the above

Ans. (c) Both the above

28. What is the procedure to be followed for hearing before the Supreme Court?
- (a) The provisions of the Code of Civil Procedure, 1908 (5 of 1908), in so far as the same applies apply in the case of appeals from decrees of a High Court
 - (b) The procedure as applicable to Tribunal would also apply to the Supreme Court
 - (c) The Provisions as applicable to Income Tax would equally be applicable
 - (d) None of the above

Ans. (a) The provisions of the Code of Civil Procedure, 1908 (5 of 1908), in so far as the same applies apply in the case of appeals from decrees of a High Court

Non Appealable Decisions and Orders (Section- 112)

29. Which are the orders against which no appeal could be preferred before First Appellate authority
- (a) An order of the Commissioner or other competent authority for transfer of proceeding from one officer to another officer;
 - (b) An order pertaining to the seizure or retention of books of account, register and other documents;
 - (c) An order sanctioning prosecution under the Act;
 - (d) An order under section 74 allowing an assessee to pay tax and other amounts adjudicated in installments.
 - (e) All of the above

Ans. (e) All of the above

Chapter - XXI

Advance Ruling

FAQ

Advance Ruling (Section 113 to 124 of CGST, also applicable of IGST wide 17 Application of certain provision of CGST Act 2016)

Q 1. Is Advance Ruling authority treated as Adjudicating Authority?

Ans. The definition of “Adjudicating Authority” excludes “Advance Ruling Authority”.

Q 2. What are the matters on which clarification can be obtained?

Ans. The clarifications can be obtained on the following matters

- (a) classification of any goods and/or services under the Act;
- (b) applicability of a notification issued under provisions of the Act having a bearing on the rate of tax;
- (c) the principles to be adopted for the purposes of determination of value of the goods and/or services under the provisions of the Act;
- (d) admissibility of input tax credit of tax paid or deemed to have been paid;
- (e) determination of the liability to pay tax on any goods and/or services under the Act;
- (f) whether applicant is required to be registered under the Act;
- (g) whether any particular thing done by the applicant with respect to any goods and/or services amounts to or results in a supply of goods and/or services, within the meaning of that term.

Q 3. What are the matters on which advance ruling cannot be sought?

Ans. No advance ruling can be sought on any matters other than those specified in response to Q 2. Additionally, if the matters on which clarification is sought are covered under the response to Q 2 but the matter is

- (a) already pending in the applicant’s case before any First Appellate Authority, the Appellate Tribunal or any Court;
- (b) the same as in a matter already decided by the First Appellate Authority, the Appellate Tribunal or any Court;
- (c) the same as in a matter already pending in any proceedings in the applicant’s case under any of the provisions of the Act;

- (d) the same as in a matter in the applicant's case already decided by the adjudicating authority or assessing authority, whichever is applicable then advance ruling authority will not provide any advance ruling.

Q 4. Can a taxable person proposing to undertake any new activity seek an advance ruling?

Ans. Yes. The provisions allows taxable person to seek advance ruling for any proposed activity.

Q 5. Can a taxable person already undertaking an activity seek an advance ruling on the same?

Ans. Yes. The provisions allow taxable person to seek advance ruling on an existing activity undertaken by him.

Q 6. Where will the Advance Ruling Authority be located?

Ans. The Authority will be located in each State.

Q 7. What will be composition of Advance Ruling Authority?

Ans. The Advance Ruling Authority will comprise of two members – one member CGST and one member SGST. The qualification, eligibility, method of appointment will be prescribed.

Q 8. What is the procedure for applying for Advance Ruling?

Ans. The following procedure needs to be adopted for obtaining advance ruling

- (a) Applicant to file application for Advance Ruling in prescribed form on payment of specified fees
- (b) The authority can call for additional records relating to the application;
- (c) The authority will decide on admission or rejection of the application
- (d) If the authority decides to admit the matter then the authority shall pronounce the advance ruling

Both in case of admission / rejection of the application and pronouncing of the ruling, the authority will provide an opportunity to be heard to the applicant and the department authorities.

Q 9. Is there a time limit within which the application needs to be disposed off?

Ans. The application needs to be disposed off within 90 days of receipt of such application.

Q 10. What if the CGST member and SGST member have different view points on the advance ruling sought?

Ans. The matter would then be referred to the Appellate Authority for advance ruling.

Q 11. Can the applicant / department file an appeal against the ruling pronounced by the Advance Ruling Authority?

Ans. Yes. An appeal can be filed before the Appellate Authority of advance Ruling within 30 days of receipt of the advance ruling.

Q 12. What will be composition of Appellate Authority for Advance Ruling?

Ans. The Appellate Authority for Advance Ruling will comprise of two members – Chief Commissioner of CGST and Chief Commissioner of SGST. The qualification, eligibility, method of appointment will be prescribed.

Q 13. Where will the Appellate Authority for Advance Ruling be located?

Ans. The Appellate Authority will be located in each State.

Q 14. What if the Appellate Authority is not able to decide on the matters referred to them by the advance authority?

Ans. In this case, it will be deemed that no advance ruling can be issued on the matters mentioned in the application.

Q 15. Can the ruling issued by the authority or order passed by the appellate authority be modified?

Ans. In case there is any mistake apparent from the records then the authority and the appellant authority can amend the ruling.

Q 16. Is the advance ruling binding for all the tax payers?

Ans. Advance Ruling will be binding only on the tax payer who has sought the clarification.

Q 17. Is the advance ruling binding on all the department officers?

Ans. No – Advance ruling will be binding only on the jurisdictional officer of the applicant and in respect of the applicant only.

Q 18. From when will the advance ruling be applicable?

Ans. Advance ruling will be applicable from the date of issue i.e. prospectively.

MCQ

Q 1. What is the meaning of applicant?

- (a) Person registered under the Act.
- (b) Person desirous of obtaining registration under the Act.
- (c) (a) & (b).
- (d) (a) or (b).

Ans. (d) (a) or (b)

Q 2. Where shall the Advance Ruling Authority be located?

- (a) The Authority shall be located in each state.
- (b) The Authority shall be located in Centre.
- (c) The Authority shall be located in both Centre & State.
- (d) None of the above

Ans. (a) The Authority shall be located in each state.

Q 3. The Advance Ruling Authority shall comprise of?

- (a) One member of CGST to be appointed by Central Government.
- (b) One member of SGST to be appointed by State Government.
- (c) (a)and (b)
- (d) None of the above

Ans. (c) (a) and (b)

Q 4. The Appellant Authority for Advance Ruling shall comprise of

- (a) Chief Commissioner of CGST as designated by the board
- (b) Commissioner of SGST having jurisdiction over the applicant
- (c) (a)and (b)
- (d) (a)or (b)

Ans. (c) (a) and (b)

Q 5. Who shall make an application for advance ruling?

- (a) Applicant
- (b) Department
- (c) Appellate Authority
- (d) None of the above

Ans. (a) Applicant

Q 6. What procedure should be followed if the members of the Authority differ on any question on which the advance ruling is sought?

- (a) The members of the authority shall state the point or points on which they differ and make a reference to the Appellate Authority for hearing and decision on such question.

- (b) The Authority will not take any decision and reject the application
- (c) The Authority will take decision on its own
- (d) None of the above

Ans. (a) The members of the authority shall state the point or points on which they differ and make a reference to the Appellate Authority for hearing and decision on such question.

Q 7. Within how many days the Authority shall pronounce its decision on advance ruling from the date of receipt of application

- (a) 30 days
- (b) 60 days
- (c) 90 days
- (d) 120 days

Ans. (c) 90 days

Q 8. Whether the ruling pronounced under Section 117 have prospective or retrospective effect?

- (a) Prospective effect
- (b) Retrospective effect
- (c) Prospective/Retrospective effect based on case to case

Ans. (a) Prospective effect

Q 9. Who can appeal to the Appellate Authority?

- (a) Jurisdictional CGST/SGST officer or the applicant
- (b) Any Taxable Person
- (c) Any citizen concerned about the ruling passed
- (d) All of the above

Ans. (a) Jurisdictional CGST/SGST officer or the applicant

Q 10. Appeal before the appellate authority can be filed within how many days?

- (a) 30 days
- (b) 60 days
- (c) 90 days
- (d) 120 days

Ans. (a) 30 days

Q 11. Under which circumstance the members of the Appellate Authority deem that no advance ruling can be issued in respect of the questions covered under the appeal

- (a) If the members of the Appellate Authority differ on any point or points referred to in appeal
- (b) If the members of the Advance Ruling Authority differ on any point or points referred to in appeal
- (c) If the jurisdictional officer differ on any point or points referred to in appeal

Ans. (a) If the members of the Appellate Authority differ on any point or points referred to in appeal

Q 12. Who has the power to amend the order issued under section 117 or 119, to rectify any mistake apparent from record?

- (a) Authority
- (b) Appellate Authority
- (c) Authority or, as the case may be, the Appellate Authority.
- (d) None of the above.

Ans. (c) Authority or, as the case may be, the Appellate Authority

Q 13. Who can notice the mistake apparent from record?

- (a) Authority, or
- (b) Appellate Authority on its own accord, or is brought to its notice by the prescribed or the jurisdictional CGST/SGST office or the applicant within a period of six from the date of order
- (c) (a) or (b)
- (d) None of the above

Ans. (c) (a) or (b)

Q 14. When should the opportunity of being heard be given to applicant or the appellant for rectification of advance ruling?

- (a) If the rectification has the effect of enhancing the tax liability.
- (b) If the rectification has the effect of reducing the amount of admissible input tax credit.
- (c) (a) or (b)
- (d) None of the above

Ans. (c) (a) or (b)

- Q 15. The Advance Ruling pronounced by the Appellate Authority shall be binding only on
- (a) The applicant who sought the advance ruling.
 - (b) The jurisdictional tax authority not related to the applicant in respect of the applicant
 - (c) All the taxable persons
 - (d) All of the above

Ans. (a) The applicant who sought the advance ruling

- Q 16. When can the Authority declare the advance ruling pronounced as void?
- (a) If ruling is obtained by suppression of material facts
 - (b) If the applicant is in the business of supplies on which clarification has been sought
 - (c) If the applicant does not engage in the business of supplies after 6 months of obtaining the ruling
 - (d) If a Supreme Court judgement is pronounced on the same issue and the judgement is exactly the opposite of the clarification issued under the ruling

Ans. (a) If ruling is obtained by suppression of material facts

Chapter - XXII

Presumption as to documents

FAQ

Presumption as to documents in certain cases (Section 125)

Q 1. Whether the documents collected during the income tax search, can be used for prosecution under GST?

Ans. Yes. Section 125 provides that any document seized from the custody of any person under any other law can be used for prosecution under the GST law unless the contrary to the truth of the said document is proved by the other party.

Q 2. Whether income tax return can be used for prosecution under GST?

Ans. Yes. Section 125 provides that any document produced by any person under any other law can be used for prosecution under the GST law unless the contrary to the truth of the said document is proved by the other party.

Admissibility of micro films, facsimile copies of documents and computer printouts as documents and as evidence (Section 126)

Q 3. Which are the modes of the documents which are considered as valid evidence?

Ans. Documents in the form of micro films, facsimile copies of documents and computer print outs and any information stored electronically in any device or media are considered as valid evidence.

Q 4. Whether all computer print outs are considered as valid evidence?

Ans. No. Computer printout is considered as valid evidence only if the following conditions are fulfilled:

- (a) The computer printout containing the statement was produced by the computer during the period over which the computer was used regularly to store or process information for the purposes of any activities regularly carried on over that period by the person having lawful control over the use of the computer;
- (b) During the said period, there was regularly supplied to the computer in the ordinary course of the said activities, information of the kind contained in the statement or of the kind from which the information so contained is derived;
- (c) Throughout the material part of the said period, the computer was operating properly or, if not, then any respect in which it was not operating properly or

was out of operation during that part of that period was not such as to affect the production of the document or the accuracy of the contents; and

- (d) The information contained in the statement reproduced or is derived from information supplied to the computer in the ordinary course of the said activities.

MCQ

Q 1. Document includes:

- (a) Written record
- (b) Printed Record
- (c) Electronic
- (d) all of the above

Ans. (d) all of the above

Chapter - XXIII

Liability to Pay in Certain Cases

FAQ

Liability in case of transfer of business (Section 127)

Q 1. Whether the transferor is still liable for the payment of the tax, interest and penalty after the transfer of business in whole or part by sale, gift, lease, leave and license, hire?

Ans. Yes. Both transferor and transferee are jointly and severally liable for payment of demand upto the time of transfer in respect of tax, interest and penalty determined before such transfer and remains unpaid or is determined thereafter.

Q 2. What are the types of business transfers covered in Section 127?

Ans. Following types of business transfers are covered in the subject provision:

- (a) Sale;
- (b) Gift;
- (c) Lease;
- (d) Leave and license;
- (e) Hire; or
- (f) In any other manner

Q 3. Whether the transferor of business is liable to pay tax / interest / penalties even in respect of the transactions undertaken after the transfer of business?

Ans. No. The transferor of business is liable to pay tax / interest / penalties arisen (whether determined prior to transfer or post transfer) up to the date of transfer of business.

Q 4. Who is liable to pay tax in respect of supplies made after the date of transfer of business?

Ans. The transferee of business is liable to pay tax after the date of transfer of business.

Liability of agent and principal (Section 128)

Q 5. Whether agent is liable for tax in case of transaction made by him on behalf of the principal?

Ans. Yes. When an agent supplies or receives any goods on behalf of the principal both agent and principal are jointly and severally liable in respect of tax payable on such goods.

Liability in case of amalgamation /merger of companies (Section 129)

Q 6. Whether the supplies made during the period between the date of order of the court and if effective date is prior to date of the order of the Court between the companies that are amalgamated liable for tax?

Ans. Yes. Such transactions of supply and receipt shall be included in the turnover of supply or receipt of the respective companies and shall be liable to tax accordingly.

Liability in case of company in liquidation (Section 130)

Q 7. Whether the directors of the company are liable for payment of tax in case of failure to pay tax or interest or penalty by the company under liquidation?

Ans. Yes. The directors of the company under liquidation are liable for payment of tax, interest and penalty due unless they prove to the satisfaction of the Commissioner that such non-payment is not attributed to any gross neglect, misfeasance or breach of duty on his part in relation to the affairs of the company.

Q 8. Whether any intimation of appointment liquidator to be given to the GST authorities in case liquidation of a company? If yes, within what period?

Ans. Yes. An intimation of appointment of the liquidator shall be given to the Commissioner within 30 days of his appointment.

Liability of directors of private company (Section 131)

Q 9. Whether the director of a private limited company is liable for the payment of tax in respect of the supply made by or to such private company?

Ans. Yes. The director of a private limited company shall be jointly and severally liable for the payment of such tax unless he proves that the non-recovery cannot be attributed to any gross, misfeasance or breach of duty on his part in relation to the affairs of the company.

Q 10. Whether the liability of the director still exists if such private limited company is converted into public limited company?

Ans. No. If a private limited company is converted into a public limited company, then the provisions of this section does not apply.

Liability of partners of firm to pay tax (Section 132)

Q 11. Whether the retiring partner is liable to pay tax?

Ans. Yes. Retiring partner shall be liable to pay tax, interest and penalty upto the date of his retirement (whether determined or not on that date).

Q 12. Whether the retiring partner is liable in respect of the transactions taken place after his retirement?

Ans. No. The Retiring partner is not liable for the transactions taken place after his retirement provided he intimates to the Commissioner by a notice in writing of his retirement within 30 days of the retirement.

Q 13. Whether the partners of the firm are liable for payment of tax dues?

Ans. Yes. The partners of the firm are jointly and severally liable for the tax dues of the firm.

Q 14. Whether liability of the retiring partner continues infinitely if the retiring partner or the firm fails to intimate the retirement within 30 days?

Ans. No. The liability continues only till the date of intimation of the retirement of the partner is received by the Commissioner.

Liability of guardians, trustees etc. (Section 133)

Q 15. Whether guardian/the trustee/the agent is liable for tax dues etc., in case of a business of minor or incapacitated person?

Ans. Yes. The Guardian, or the Trustee, or the Agent as the case may be who is conducting the business for the benefit of minor or incapacitated person is liable for payment of tax dues.

Liability of Court of Wards etc. (Section 134)

Q 16. Whether Court of Wards controlling the estate of a taxable person is liable for the payment of tax dues in respect of the transactions entered by the estate?

Ans. Yes. The Court of Wards is liable for the payment of tax dues in respect of the transactions entered by the estate as if they were conducting the business themselves.

Special provision regarding liability to pay tax, interest or penalty in certain cases (Section 135)

Q 17. Whether a legal representative be made liable for tax dues payable by a deceased person?

Ans. Yes, legal representative is made liable for the tax dues of the deceased person even if it is determined after death.

Q 18. Whether entire tax dues of the deceased person could be recovered from the legal representative?

Ans. In case of continuation of business: the legal representative or the any other person who carries on the business after his death is liable to pay tax, interest, penalty or any other due which is due from the deceased person; or

In case of discontinuation of business before or after his death: only the legal representative is liable to pay the tax, interest, penalty or any other dues to the government. The liability of the legal representative in case of discontinued business is only to the extent of property or estate received from such deceased person.

Q 19. In case of partition of HUF or AOP, whether members of the HUF/AOP are liable for tax dues?

Ans. Yes. The member or the group of members is/are liable jointly and severally for tax dues that are arisen in respect of the transactions upto the time of partition.

Q 20. Whether the partners of the firm are liable for tax dues in case of dissolution of a firm?

Ans. Yes. Every person who was a partner upto the time of dissolution is jointly and severally liable to pay the tax, interest or penalty in respect of the supplies made till the dissolution.

Q 21. Whether the guardian or trustee who carries on business for a beneficiary's liable for tax dues in case of termination of guardianship or trust?

Ans. Yes. The guardian or trustee is liable to pay the tax, interest or penalty in respect of the supplies made till his termination.

Liability in other cases (Section 136)

Q 22. In case of discontinuance of business of a firm or AOP or HUF, who would be liable to pay the tax and other dues?

Ans. Every partner of the firm or member of the AOP or HUF at the time of discontinuance shall be jointly and severally liable to tax and other dues upto the date of discontinuance.

Q 23. In case of reconstitution of partnership firm how and to what extent the partners liability of tax, interest and penalty is determined?

Ans.

- Upto the date of reconstitution, all the partners of the firm prior to the date of reconstitution
- After the date of reconstitution, all partners as they exist after reconstitution

MCQ

Liability in case of transfer of business (Section 127)

Q 1. Transfer of business includes

- (a) Sale

- (b) Lease
- (c) License
- (d) All the above

Ans. (d) All the above

Q 2. Who is liable to pay the tax in case of transfer of business?

- (a) Transferor
- (b) Transferee
- (c) Both jointly and severally
- (d) jointly

Ans. (c) Both jointly and severally

Liability of agent and principal (Section 128)

Q 3. Who is liable to pay the tax in case of Principal and Agent?

- (a) Principal
- (b) Agent
- (c) Both jointly and severally
- (d) Jointly

Ans. (c) Both jointly and severally

Liability in case of amalgamation /merger of companies (Section 129)

Q 4. When two or more companies are amalgamated, the liability to pay tax on supplies between the effective date of amalgamation order and date of amalgamation order would be on -

- (a) Transferee;
- (b) Respective companies;
- (c) Any one of the companies;
- (d) None of the above.

Ans. (d) Respective Companies.

Q 5. In case a particular word is not defined in the CGST Act, then it is possible to refer to:

- (a) Companies Act, 1956
- (b) Companies Act, 2013,
- (c) Companies Act, 1913

(d) General Clauses Act, 1897

Ans. (b) Companies Act, 2013

Q 6. In case of amalgamation between two companies, such companies shall be treated as two distinct companies till –

- (a) Till the date of the High Court order
- (b) Till the effective date of merger
- (c) Till the date of cancellation of registration
- (d) None of the above

Ans. (a) Till the date of the High Court order

Liability in case of company in liquidation (Section 130)

Q 7. Intimation regarding appointment of liquidator should be given to the Commissioner within 30 days of

- (a) Liquidation
- (b) Cancellation of registration
- (c) Appointment of Liquidator
- (d) Order of Court

Ans. (c) Appointment of Liquidator

Q 8. Commissioner will notify the amount of liability within how many days of intimation

- (a) 3 months
- (b) 30 days
- (c) 60 days
- (d) 6 months

Ans. (a) 3 months

Q 9. When shall the Director be not liable to pay the tax dues if the company is not able to pay?

- (a) Liquidator refuses to pay
- (b) Auditor refuses to pay
- (c) If the non-recovery is not due to gross neglect of the Director
- (d) None of the above

Ans. (c) If the non-recovery is not due to gross neglect of the Director

Liability of directors of private company (Section 131)

Q 10. When shall the Director of a private limited Company be not liable to pay the tax dues if the company is not able to pay?

- (a) In all cases
- (b) Company refuses to pay
- (c) If the non-recovery is not due to gross neglect, misfeasance or breach of duty of the Director
- (d) None of the above

Ans. (c) *If the non-recovery is not due to gross neglect misfeasance or breach of duty of the Director*

Liability of partners of firm to pay tax (Section 132)

Q 11. Retiring partner should intimate the retirement to

- (a) Department
- (b) Government
- (c) Commissioner
- (d) All of the above

Ans. (c) *Commissioner*

Q 12. Intimation to the Commissioner has to be given within.....

- (a) 1 month
- (b) 60 days
- (c) 90 days
- (d) 45 days

Ans. (a) *1 month*

Q 13. If the intimation is delayed to the Commissioner, then the retiring partner is liable to pay tax dues till:

- (a) The date of receipt of intimation by the Commissioner
- (b) Till the date of acceptance of intimation by the Department
- (c) Till the date of retirement
- (d) Till the date of show cause notice

Ans. (a) *The date of receipt of intimation by the Commissioner*

Liability of guardians, trustees etc. (Section 133)

Q 14. In case of business carried on by minor or other incapacitated person through Guardian/ Agent who is liable to pay tax?

- (a) Guardian
- (b) Friend
- (c) Business Partner
- (d) None

Ans. (a) *Guardian*

Q 15. The dues recoverable under this section includes

- (a) Only Interest
- (b) Any dues which are recoverable under this Act
- (c) Only tax
- (d) Only Penalty

Ans. (b) *Any dues which are recoverable under this Act*

Liability of Court of Wards etc. (Section 134)

Q 16. If the estate or any portion of the estate of a taxable person is under the control of the Court of Wards, Administrative General etc., the tax due from such taxable person is liable to be paid by -

- (a) Court of Wards.
- (b) Taxable Person
- (c) Legal representative of taxable person
- (d) None of the above

Ans. (a) *Court of Wards*

Q 17. The Court of Wards, Administrative General, etc., must be appointed by

- (a) Supreme Court
- (b) High Court
- (c) Any court
- (d) None of the above

Ans. (c) *Any Court*

Q 18. The dues recoverable under this section includes

- (a) Only Interest
- (b) Any dues which are recoverable under this Act
- (c) Only tax
- (d) Only Penalty

Ans. (b) Any dues which are recoverable under this Act

Special provision regarding liability to pay tax, interest or penalty in certain cases (Section 135)

Q 19. Who is liable to pay tax if the business of an individual is discontinued before his death?

- (a) Board of Directors or Manager
- (b) Any member of his person who is willing to pay
- (c) Legal representative of taxable person
- (d) Employee

Ans. (c) Legal representative of taxable person

Q 20. The legal representative or any other person of an individual who is dead is liable to pay tax, only if -

- (a) The business has been carried on by the legal representative
- (b) The business has been carried by the legal representative or any other person
- (c) The business has been carried by any other person
- (d) None of the above.

Ans. (b) The business has been carried on by the legal representative or any other person

Q 21. The dues recoverable under this section includes

- (a) Only Interest
- (b) Any dues which are recoverable under this Act
- (c) Only tax
- (d) Only Penalty

Ans. (b) Any dues which are recoverable under this Act

Q 22. As per this section, the member or group of members of HUF or AOP is/are liable to pay tax on taxable supplies -

- (a) Even after its partition
- (b) Upto the time of partition

- (c) Both (a) and (b)
- (d) None of the above

Ans. (b) Upto the time of partition

Liability in other cases (Section 136)

Q 23. In case of discontinuance of HUF business, the liability would arise till the date of

- (a) Discontinuance
- (b) Court verdict
- (c) As mutually agreed upon by the HUF members
- (d) Determination of liability by the Department.

Ans. (a) Discontinuance

Q 24. The expression 'firm' would include a _____

- (a) Company
- (b) LLP
- (c) HUF
- (d) AOP

Ans. (b) LLP

Q 25. In case of discontinuance of the AOP, the liability of the member exists in respect of the tax dues imposed _____

- (a) Prior to the date of discontinuance
- (b) After the date of discontinuance
- (c) Both prior and after the date of discontinuance
- (d) None of the above

Ans. (c) Both prior and after the date of discontinuance

Chapter - XXIV

Transitional Provisions

FAQ

General Provisions (Section 165)

- Q 1. Who will administer the Central GST & State GST?
- Ans. GST officers as appointed under section 5 of the Revised Model CGST/SGST law will administer the Central GST & State GST respectively.
- Q 2. Can a state excise officer / food inspector/Profession tax officer be appointed as GST officer?
- Ans. The officers who are appointed under laws which are not being subsumed in GST cannot be appointed as GST officers.
- Q 3. How will the jurisdiction of the transitioned officers be identified?
- Ans. The respective SGST/CGST officers have been empowered under section 6 & 7 of the SGST/CGST law to administer the respective acts.
- Additional cross administrative powers have been given to the said officers to also administer specific provisions of the corresponding Central / State law.
- However, the jurisdiction will be determined through rules specified.

Migration of existing taxpayers to GST (Section 166)

- Q 4. What is the primary condition for provisional registration?
- Ans. Every person registered under any of the earlier laws and having a valid PAN shall be issued a certificate of registration on a provisional basis.
- Q 5. What will be the validity of the provisional certificate?
- Ans. The provisional certificate issued shall be valid for a period of six months from the date of its issue. The said validity period may be extended for such further period as the Central/State Government may, on the recommendation of the Council, notify.
- Q 6. When will the provisional registration be converted into final registration?
- Ans. A person holding the provisional registration certificate shall submit the prescribed information and documents as per the GST rules within 6 months or extended period. On furnishing the information and documents the final registration will be issued.

Q 7. GST Registration for existing registered dealer has to be taken by submission of documents or will it be done automatically?

Ans. Data has to be submitted on GSTN and only then registration will be given. A provisional registration will be given for a period of 6 months, within which the documents have to be submitted for obtaining the final registration.

Q 8. What happens if the documents are not furnished within the time prescribed?

Ans. The certificate of registration issued to a person provisionally may be cancelled if such person fails to furnish the prescribed information within the specified time.

Q 9. Can a person voluntary opt out of GST who is registered under the earlier law?

Ans. Yes, by application a person can opt out of GST.

Q 10. What will be the status of the provisional registration if the person claims to be not liable for registration under GST?

Ans. The Provisional certificate shall be deemed to have not been issued if the said registration is cancelled in pursuance of an application filed by such person that he was not liable to registration.

Q 11. What will be the position of the provisional registration of a composite dealer?

Ans. Even an existing composite taxpayer has to specifically apply for composition tax and the receipt of provisional certificate would not be considered as automatic transition to composite scheme.

Q 12. Can a VAT dealer opt for composition scheme after the time prescribed?

Ans. When a registered taxable person does not opt to pay tax under composition scheme within the time prescribed, he shall be liable to pay tax under regular provisions.

Q 13. What happens in case tax payers have distinct VAT registrations in the same State?

Ans. The transitional provisions would allot one registration certificate in each State based one PAN even though previously such person had multiple registrations in a State, unless they qualify as distinct business verticals under the GST law.

Q 14. What happens where distinct registrations are obtained under the Central Excise/ Service Tax law for distinct units/ business premises in one State?

Ans. All units/ business premises registered either under Central Excise or Service Tax law would be consolidated into a single CGST registration for that State, unless they qualify as distinct business verticals under the GST law.

Amount of CENVAT credit carried forward in a return to be allowed as input tax credit (Section 167)

Q 15. How will a manufacturer/ service provider carry forward the Cenvat credit in his electronic credit ledger?

Ans. The amount of Cenvat credit in the return relating to the period ending on the day immediately preceding the appointed date shall be allowed to be carried forward as credit in the electronic credit ledger under the GST, provided that the said credit is admissible as input credit under GST law.

Q 16. How will a registered tax payer under VAT [and Entry Tax] carry forward the input credit in his electronic credit ledger?

Ans. The amount of input tax credit in the return relating to the period ending on the day immediately preceding the appointed date shall be carried forward as credit in the electronic credit ledger under the GST, provided that the said credit is admissible as input credit under GST law.

Q 17. Can a registered tax payer opting to pay tax under composite scheme under GST be eligible for Input Tax Credit?

Ans. The amount of input tax credit in the return relating to the period ending on the day immediately preceding the appointed date shall lapse and will not be allowed to be carried forward as input tax credit to a person opting to pay tax under composite scheme.

Q 18. What is the condition for a dealer to take credit of VAT and Entry tax?

Ans. A Registered tax payer will be eligible to carry forward the credit of VAT and Entry available in the return immediately preceding the appointed date (last return). The SGST law provides a time period of ninety days from the appointed date to furnish the last return to claim such credit.

Note: The said amount should also be admissible as input tax credit under the GST law.

Q 19. Will a person registered in a State say Maharashtra be eligible to claim credit if he does not take registration in that State under GST for any reason say closure of operations etc.?

Ans. The credit claimed in the return of a particular State will ordinarily be eligible to be carried forward only in the succeeding SGST law of that State, in the instance case Maharashtra, and cannot be availed as credit in any other State GST Law.

Q 20. Is there any time limit on the period to which the credit being brought forward pertain to?

Ans. As long as the credit is eligible (including the condition on time limit) under the earlier State / Central law, credit can be rightly availed. There is no specific time limit on the period to which such transitional credit should pertain to under the CGST/ SGST law.

Q 21. How can Entry tax credit be claimed as eligible input Credit under the GST law?

Ans. The respective States have different provisions for claiming credit of Entry Tax. Hence, in the State where input credit for entry tax is permitted, such credits, can be carried forward as SGST credit in that State under SGST Law.

Q 22. Whether credit, eligible and claimed by tax payer in any return preceding the last return but failed to bring forward in the last return, eligible for automatic carry forward?

Ans. According to the plain reading of the provisions, only the credit carry forward in the last return is eligible for automatic carry forward in the GST return. The tax payer can apply for refund under other transitional provisions.

Q 23. What is the treatment of various components of Cenvat Credit (such as service tax, excise duty, cess, etc.) in GST transition?

Ans. All components of Cenvat Credit in the last return would merge into one single input tax credit under the CGST credit ledger. The taxes being subsumed lose their individual identity under the GST law.

Q 24. Whether surcharge/ cess levied under respective State laws on sale of goods is eligible for SGST credit under the GST law?

Ans. If the surcharge or cess which is levied under the respective State laws is eligible for credit, then such credit is eligible for carry forward as SGST credit in that State under SGST Law.

Q 25. How will the credit be claimed in case more than one registration of a single taxable person is available in a State, say two manufacturing units in one State?

Ans. Since multiple registrations of a particular State would be consolidated into a single GST registration in that State (except in case of distinct business verticals), the credits brought forward in multiple returns would also be consolidated into a single input tax credit in the respective SGST ledger of that State.

Q 26. What happens to ineligible transitional credit being carried forward in the return as on the appointed date?

Ans. Where any transitional credit carry forward in the GST return is held to be ineligible under an assessment/ adjudication proceeding, whether initiated before or after the appointed date, such credit shall be recovered as an arrear of tax under the GST law.

Q 27. If the amount of duty, tax or cess carried forward as per the accounts is greater than the return, which amount will be allowed to be carried forward?

Ans. The amount of duty, tax or cess carried forward as per the accounts will be immaterial. The input tax credit carried forward as per the last return under the earlier law for the period ending with the day preceding the day when the GST becomes applicable will only be taken into account.

Q 28. Will the GST officer issue any order based on which such credit are availed?

Ans. There is no such pre-condition. Credit can be availed suo-motu based on enabling provisions. However, the GST officers are empowered to verify this credit during assessment proceedings and any amount incorrectly availed can be recovered as tax under GST law.

Unavailed Cenvat credit on capital goods, not carried forward in a return, to be allowed in certain situations (Section 168)

Q 29. Is there a provision to claim credit if not carried forward in the return for capital goods?

Ans. Yes. Section 168 provides for claiming unavailed credit in respect of capital goods only. However similar provisions do not exist for inputs and input services, except inputs in transit as on the appointed date.

Q 30. Can a tax payer claim cenvat credit of unavailed cenvat credit under earlier law?

Ans. Credit of the unavailed credit in respect of capital goods, not carried forward in the last return is available for credit under the GST law provided it is admissible as Cenvat credit under the GST law. It may be clarified that the aggregate of credit availed under the GST law and the earlier law cannot exceed total of eligible credit on such capital goods.

Q 31. What is the condition for claiming Cenvat credit on-

- Input and Input services
- Capital goods

For instance - Goods were received before 1st April, 2016 but no CENVAT Credit or partial CENVAT Credit was availed till the year 2016-17 (Assume applicability of GST from 1st April, 2017)?

Ans. Credit on inputs and input services already availed under the earlier law is eligible for automatic carry forward under the GST law. However, credit of input and input service which is not availed until the last return is not available as credit under the GST law, except in some circumstances as answered in the previous question.

As per Rule 4(2) (b) of the CENVAT Credit Rules, the CENVAT Credit on capital goods which has not been availed in the first year will be available in any financial year subsequent to the financial year in which it was purchased. The CENVAT Credit Rules does not prescribe any time limit for availment of CENVAT Credit on Capital Goods. Therefore, credit on capital goods can be claimed to the extent of unavailed portion, if it is admissible as credit under the GST law.

Credit of eligible duties and taxes in respect of inputs held in stock to be allowed in certain situations (Section 169)

Q 32. What will happen if the inputs, which are intended for use for making taxable supplies, are ultimately used for exempt supplies?

Ans. If the inputs in stock in respect of which credit was allowed, is ultimately used for exempt supplies instead of taxable supplies, then of the credit on such inputs as is used for exempt supplies will be disallowed in the electronic credit ledger. If there is no credit is remaining as per the electronic credit ledger, then the same will have to be paid in cash by the taxable person.

Q 33. Apart from Manufacturer or Service Provider who else is eligible for Cenvat credit?

Ans. Following persons are also eligible for Cenvat credit as GST credit even though they were not eligible under the earlier law

- Person who was not liable to be registered under the earlier Cenvat Credit Rules for instance small scale unit manufacturers.
- Person who were engaged in the manufacture of exempted goods
- Provider of exempted services
- Provider of works contract service and availing the benefit of notification No. 26/2012-Service Tax, dated 20.06.2012
- First stage dealer or a second stage dealer or a registered importer.

The above category of persons can claim credit eligible duties and taxes in respect of inputs held in stock and inputs contained in semi-finished or finished goods held in stock on the appointed day.

Q 34. Under what circumstances are the above categories of persons (i.e. person mentioned in Q 33 above) eligible to claim credit?

Ans. The aforesaid persons can claim credit on fulfillment of the following conditions-

- such inputs are used or intended to be used for making taxable supplies under this Act;

- the said taxable person passes on the benefit of such credit by way of reduced prices to the recipient;
- the said taxable person is eligible for input tax credit on such inputs under the GST Law;
- the said taxable person is in possession of invoice and/or other prescribed documents evidencing payment of duty under the earlier law;
- such invoices and /or other prescribed documents were issued not earlier than twelve months immediately preceding the appointed day;
- the supplier of services is not eligible for any abatement under the Act.

Q 35. How will the condition of reduced price to recipient be satisfied?

Ans. The component of eligible duties and taxes should be reduced from the ordinary sale price to pass on the benefit of reduced prices. This is illustrated by way of a comparative example –

Particulars	Earlier Law	GST Law
Basic Cost	100.00	100.00
Excise @ 12.5%	12.50	- (since creditable)
Total Cost	112.50	100.00
Selling Price (excl. applicable taxes)	162.50	150.00
Gross Profit	50.00	50.00

In the above illustration if the registered taxable person sells at Rs 150, only then he will get the benefit of credit.

Q 36. Can a trader (other than a First stage dealer or a second stage dealer) claim the Cenvat credit?

Ans. No, a trader who is not a first stage dealer or second stage dealer cannot claim Cenvat Credit.

Q 37. Will Central Sales Tax (CST) paid under the earlier law be available as credit under GST?

Ans. No, the transitional provisions do not permit credit of Central Sales Tax paid, even though such component may be present in inputs in stock or inputs contained in Semi-finished goods or finished goods.

Q 38. Can stock held for more than one year be eligible to claim GST credit?

Ans. No. The provision contains a condition that only stock in respect of which the duty

paying document is issued within one year from the appointed date is eligible for credit under GST.

Q 39. What happens if the above persons (i.e. FSD/SSD or Registered importer, etc.) are not in possession of the duty paying document?

Ans. GST law contains an enabling provision which permits credit to be claimed even if the duty paying documents are not in possession of the person availing the credit. The terms, conditions, limitations and safeguards for such situations would be prescribed in the rules.

Q 40. If a taxable person under GST law was engaged in the provision of exempt services which becomes taxable in GST, will the taxable person under GST be allowed the credit in respect of the inputs in his stock?

Ans. Yes, such a taxable person would be eligible for credit on inputs in stock or contained in semi-finished goods or finished goods and such inputs are actually used or intended to be used for provision of taxable supplies under the GST law.

Credit of eligible duties and taxes in respect of inputs held in stock to be allowed in certain situations (Section 170)

Q 41. Is there any provision which deals with the CENVAT credit for a taxable person dealing in both non-exempted as well as exempted goods/ services in earlier law?

Ans. Yes, the provisions of section 170 identifies this situation and allow credit available in the return for taxable goods/service and credit on input, semi-finished goods and finished goods on exempt goods/ services.

Credit of eligible duties and taxes in respect of inputs or input services during transit (Section 171)

Q 42. Can credit be claimed in respect of CENVAT, Entry tax and VAT paid on goods under present law and which is in transit as on the transition date?

Ans. Yes, credit can be claimed subject to the following prerequisites -

1. The registered taxable person should record the duty paid in his books of accounts within 30 days or such extended time which may be prescribed and
2. A statement should be furnished in prescribed form.

Q 43. Will the credit be available if the Invoice is made on or before 31st March, 2017 but is received by the supplier on or after 1st April, 2017 assuming the applicability of GST from 1st April, 2017?

Ans. Section 171 envisages such a situation wherein Invoice is raised prior to the appointed date and received after the appointed date and credit would be permissible provided the purchase is recorded by the receiver within 30 days in his books of accounts.

Q 44. If any credit on inputs/input services has been missed to be availed or in respect of which duty paying documents are not available as on the appointed date, will it be eligible for credit under section 171?

Ans. Credit under section 171 can only be claimed in respect of services / inputs which are in transit and received after the appointed date. A strict reading of the provisions does not enable credit in circumstances where invoice is not available or missed to be availed under the earlier law.

Q 45. Can credit of services invoiced prior to the appointed date but the services are completed after the appointed date be claimed as credit?

Ans. Yes, credit can be claimed on the prerequisite that the invoice is recorded within 30 days from the appointed date.

Credit of eligible duties and taxes on inputs held in stock to be allowed to a taxable person switching over from composition scheme (Section 172)

Q 46. What are the provisions of credit of duties and taxes for a registered taxable person paying tax under composition scheme under earlier law and switching over to the regular provisions under the GST law?

Ans. A registered tax person can claim credit of eligible duties in respect of inputs; inputs contained in semi-finished goods/ finished goods held in stock as on the appointed date. Such person should be in possession of the invoice/duty paying document which is not more than 12 months old. Such input should also be eligible input tax credit under the GST law.

Q 47. Will persons claiming abatement under service tax notifications and paying service tax at an effective rate lower than 15% be termed as 'composition tax payers' for purpose of section 172 of the CGST/ SGST law?

Ans. The services covered under abatement notifications (such as 26/2012-ST) will not be covered under the said provisions. The abatement notifications are for the purpose of determination of the taxable value on which service tax is assessable and cannot be considered as composition rates. Such services may qualify as 'exempted services' under the Cenvat Credit rules and cannot be termed as services subject to composite tax rates. However, credit can be claimed under the conditions of section 169 of the CGST/SGST law.

Q 48. What is the key difference in the conditions for claiming credit between section 169 and 172?

Ans. While section 169 is for claim of credit on exempted goods/ services, section 172 is for claim of credit on composition tax payers.

Section 169 contains a condition that the input tax credit availed should be passed on in the form of reduced price to the recipient under the GST law. However, section 172 does not contain such a condition. This difference is a key to interpreting the applicability of the provisions of section 169 and 172 to certain tax payers.

Q 49. Whether VAT dealers claiming standard deductions towards labour and other like charges in case of works contracts under the respective VAT laws be termed as composition tax payers?

Ans. The VAT dealers who are determining the labour and other like charges portion of the works contract based on the standard deduction method (such as 30%, 25% etc.) cannot be termed as falling under composition scheme of tax payment. These are merely alternative statutorily recognised valuation provisions for determining the materials transferred in execution of works contract and cannot be a scheme of tax payment 'in lieu' of a normal scheme.

Q 50. Who are the VAT dealers who can be considered as composition tax payers?

Ans. VAT dealers opting to pay VAT on a fixed rate (such as 1% or 4%) in lieu of a regular tax under VAT would be considered as composition tax payers for e.g. Maharashtra VAT dealers opting for payment of VAT on 1% of the flat value including land as composition tax would be covered here. Similarly, in certain States, small retailers, caterers, sweet meat stalls can opt for composition if the turnover is below a specified limit.

Q 51. If a dealer paying tax under composition scheme under earlier law continues to pay tax under composition scheme under the GST law will the dealer get any credit under the GST law? Would the answer change if the dealer subsequently opts out of composition scheme?

Ans. No, the dealer will not get any credit when he changes over to composition scheme under GST. The position would be same even if he switches out of composition scheme subsequently under GST, except in respect of goods held in stock as on the date of switchover.

Exempted goods returned to the place of business on or after the appointed day (Section 173)

Q 52. What is the implication of GST in respect of exempted goods removed before the appointed date and returned after the appointed date?

Ans. If any exempted goods are sold/removed under the earlier law are returned within six months of the appointed date, no tax is applicable under the GST law. In case goods are returned after six months from the appointed date, tax is payable by the person returning the goods under the GST law.

Duty (Tax – in SGST Act) paid goods returned to the place of business on or after the appointed day (Section 174)

Q 53. What are the implications of GST in respect of duty paid goods removed within six months prior to the appointed date and returned after the appointed date?

Ans. In case goods are being returned by registered taxable person general provisions of supply under GST will apply and the person receiving the goods can also claim the input tax credit under the general provisions. However, where the goods are returned by a person other than registered taxable person then the original supplier

Inputs removed for job work and returned on or after the appointed day (Section 175); Semi-finished goods removed for job work and returned on or after the appointed day (Section 176) and Finished goods removed for carrying out certain processes and returned on or after the appointed day (Section) 177

Q 54. What are the implications of GST on the principal manufacturer in respect of goods sent on job work before the appointed date and received within 6 months from the appointed date?

Ans. In case the goods are returned within 6 months from the appointed date, no tax shall be payable by the original supplier. In case the goods are returned after 6 months from the appointed date, the input tax credit claimed by the original supplier shall be recovered in terms of section 184. In either case, both the principal manufacturer and job worker shall declare the details of goods held in stock by the job worker as on the appointed date in the prescribed form.

Q 55. Who is liable to pay tax when the processed inputs are not returned within the time limit specified?

Ans. When the processed inputs are not returned within specified time limit, the principal manufacturer is liable to reverse the input tax credit already claimed, which shall be reversed under the GST law.

Q 56. Is declaration to the effect of stock held by job worker on behalf of manufacturer, compulsory to be submitted to the prescribed authority?

Ans. Yes, filing of declaration by both the manufacturer and the job worker showing the details of inputs held in stock by job worker on behalf of manufacturer on the appointed day is a primary condition to avail exemption specified by this section.

Q 57. Whether input tax credit recoverable under the GST Act when the time limit conditions are not fulfilled, has to be paid in cash or can it be adjusted to credit lying in the electronic credit ledger?

Ans. The amount is recoverable under the provisions of section 184 of the GST law and hence has to be paid in cash. Moreover, this amount is also not eligible for input tax credit subsequently.

Q 58. What are the tax implications in respect of goods which are returned after the period of six months?

Ans. It appears that the general provisions of CGST/ SGST would apply on such goods and GST may be held to be applicable. However, one may also examine section 189 which specifically states that where the taxable event in respect of supply of goods has arisen before the appointed date, the liability to tax would be determined in terms of the provisions of the earlier law.

Q 59. Whether inputs in semi-finished goods or finished goods which are removed from the factory under earlier law to the job work can be directly sent to any other place of business premises for further supply, processing, etc.?

Ans. The provision only permits semi-finished goods and finished goods to be directly sent to other registered premises and need not be returned to the principal manufacturer's premises. In case of inputs, the goods necessarily have to be returned to the principal manufacturer's premises after completion of the job work.

Q 60. What are the tax implications in case of semi-finished goods and finished goods are directly removed from the job worker premises?

Ans. In case of semi-finished goods, the goods can be directly removed from the job worker premises to any other premises of a registered taxable person for the purpose of supplying goods there from on payment of applicable tax. In case of finished goods, the goods can be directly removed from the job-worker premises to any place on payment of applicable taxes. However, the above relaxation is not available for inputs.

Q 61. Who is liable to pay tax in respect of goods supplied after completion of job work from the job-worker premises?

Ans. In case of job work, the principal manufacturer affecting the supply has to include the job worker premises in his certificate of registration. The supply being affected by the principal manufacturer and not by the job worker (except in cases where the job worker acts as an agent of the manufacturer), tax liability is on the principal manufacturer.

In case where the job worker also acts in the capacity of an agent, there would be a deemed supply from the principal to agent and subsequently from the agent for the supply in which case the tax liability will be on both the principal manufacturer and the job worker with corresponding credits as well.

Issue of supplementary invoices, debit or credit notes where price is revised in pursuance of a contract (Section 178)

Q 62. What are the implications in respect of upward price revision for goods removed or services provided prior to the appointed date?

Ans. The supplier shall issue a supplementary invoice/ debit note within 30 days of the price revision and charge GST on such supplementary invoice/ debit note. The rate as per the GST schedule may apply, however this is a contentious matter.

Q 63. What are the implications in respect of downward price revision for goods removed or services provided prior to the appointed date?

Ans. The supplier shall issue a credit note within 30 days of price revision and mention the value of GST on such credit note. The original supplier will be allowed to reduce his tax liability subject to the recipient reducing his input tax credit to such extent.

Pending refund claims to be disposed of under earlier law (Section 179)

Q 64. What is the status of refund claims of Cenvat credit/duty/tax or interest pending as on the appointed date?

Ans. The pending refund claims will be sanctioned in accordance with the terms and conditions specified under the earlier law and shall be paid in cash and will not get credited to his electronic credit ledger. Refund can only be claimed of amounts which are not carried forward in the GST law.

Q 65. What happens if the refund claim is rejected?

Ans. The refund claim of Cenvat credit/ input tax is rejected the same shall lapse and further the tax payer is not entitled to claim any credit of such amounts.

Refund claims filed after the appointed day for goods cleared or services provided before the appointed day and exported before or after the appointed day to be disposed of under earlier law (Sec 180)

Q 66. What happens to the refund claims filed after the appointed date in respect of goods cleared or services provided under the earlier law?

Ans. Any application of refund filed after the appointed date for a claim pertaining to the earlier law shall be disposed off as per the terms and conditions of the earlier law. The claim would be eligible irrespective of export of goods or services before or after the appointed date, for instance input credit pertaining to April, May and June can be claimed in June even if the export is in June (assuming GST is implemented in June 2017).

Q 67. What happens to goods removed from factory for export prior to appointed date and exported from the customs port after the appointed date?

Ans. Section 180 permits refund of Cenvat credit or duty paid under earlier law even if the goods are exported after the appointed date.

Refund claims filed after the appointed day for payments received and tax deposited before the appointed day in respect of services not provided (Section 181)

Q 68. What happens to taxes deposited under earlier law if such services are not provided even after the appointed date?

Ans. Refund can be claimed in cash in respect of such taxes even after the appointed date in respect of taxes collected but services not provided, however the claim shall be filed within one year from the relevant date as per the provision of section 11B of Central Excise Act.

Claim of Cenvat credit to be disposed of under the earlier law (Section 182)

Q 69. What happens to tax appeals/ revisions, review or reference relating to claim of Cenvat credit/ input tax credit under the earlier law and pending as on the appointed date?

Ans. In case the proceedings result in admissibility of credit, such credit shall be refunded in cash as per the provisions of earlier law provided the claim of refund is filed within one year from the relevant date. No refund is available in case the amount of Cenvat credit is carried forward in the return.

If the proceedings result in disallowance of credit, it shall be recoverable as arrears of tax under the GST law and such amount shall be not admissible as credit under the GST law.

Finalization of proceedings relating to output duty or tax liability (Section 183)

Q 70. If the matter in appeal is remanded back to adjudication, will the matter be dealt under the earlier law or as per the GST provisions?

Ans. Till a particular proceeding is completely disposed off, it will be carried out under the

provisions of the earlier law. So, if a particular matter is remanded back to adjudication, then the same will be dealt as per the provisions of the earlier law itself. Only if the amount is found to be recoverable after the disposal of the proceedings, then the amount will be recovered under section 72 of the Revised GST Law.

Q 71. Can the State officers exercise jurisdiction over disposal of proceedings relating to CENVAT Credit?

Ans. No, all the proceedings till the disposal of appeal will be managed as per the provision of the earlier law. The State officers under the earlier law did not have jurisdiction to conduct the proceedings relating to CENVAT Credit. So, they will not be able to exercise jurisdiction for disposal of proceedings relating to CENVAT Credit.

Treatment of the amount recovered or refunded in pursuance of assessment or adjudication proceedings (Section 184)

Q 72. Whether input tax credit is available to the buyer or service recipient in respect of amounts payable due to assessment, appeal, review or revision proceedings under the earlier law?

Ans. Any amount recovered from the tax payer arising out of proceedings initiated under the earlier law shall not be eligible for Input tax credit under the GST law but shall be refunded in cash.

Q 73. What will be the status of adjudication/ assessment, appeal, review, revision or reference proceedings which are initiated before or after the appointed date in respect of periods covered under the earlier law?

Ans. The adjudication or assessment proceedings shall be conducted and disposed off under the provisions of the earlier law. If any amount becomes recoverable as a result of the proceedings including appeal/ revision/ review or reference, such amount shall be recovered as arrears of duty or tax under the GST law. If any amount becomes refundable to the tax payer, such amount shall be refunded in cash under the GST law.

Treatment of the amount recovered or refunded pursuant to revision of returns (Section 185)

Q 74. What are the implications on the tax payer in case of revision of returns filed in respect of periods covered under the earlier law?

Ans. In case where the revision of return results in additional amount payable by the tax payer, such amount is recoverable in terms of the provisions of the GST law.

In case where the revision of return filed within the prescribed time limit results in refund or increase in credit to the tax payer, such amount is refundable to the person under the earlier law.

Treatment of long term construction / works contracts (Section 186)

Q 75. What is the implication of GST on long term works contracts or construction contract?

Ans. Good or service supplied on or after the appointed date shall be taxable under the GST law. Goods and services chargeable to tax/duty under the earlier law shall continue to be taxable under the earlier law. For determining whether the taxable event has occurred (such as removal, point of taxation, sale, etc.) under the earlier law, it is important that the provisions of the earlier law are examined.

Q 76. If services are provided pursuant to a contract entered into prior to the appointed date, which tax is payable?

Ans. All supplies after the appointed date shall be liable to tax under the CGST/SGST Act.

Progressive or periodic supply of goods or services (Section 187)

Q 77. What are the conditions to pay tax under earlier law?

Ans. There are two conditions to be fulfilled in order to pay tax under the earlier laws as follows:

- (a) The consideration (fully or partly) should have been received prior to the appointed date; and
- (b) Duty or Tax should have already been paid under the earlier law.

Q 78. Is it mandatory that the supply must have completed prior to the appointed date?

Ans. No. Time of supply is not a condition to tax the supply under earlier laws. The supply may be initiated or completed after the appointed date.

Q 79. Should the duty / tax under the earlier law be paid before the appointed date?

Ans. No such condition has been prescribed under the Section. The assessee may pay the duty / tax under the earlier law after the appointed date if such facility is available.

Taxability of supply of services in certain cases (Section 188)

Q 80. Section 188 specifies that the supply shall be taxed under the earlier laws if the point of taxation arises prior to the appointed date. To check the point of taxation, reference is to be made to the Point of Taxation Rules, 2011 or the GST laws?

Ans. To check point of taxation, one needs to refer to the Point of Taxation Rules, 2011.

Q 81. What is the meaning of the Explanation to Section 188?

Ans. The Explanation clarifies that the tax in respect of services shall be payable under the GST law if the point of taxation of the supply is after the appointed day

Credit distribution of service tax by ISD (Section 190)

Q 82. What is the situation covered in Section 190 with respect to distribution of Service Tax?

Ans. Section 190 covers a situation wherein even if the service has been received prior to the appointed date and Service tax has been charged on such services, the ISD may distribute such input of service tax as CGST under this Act.

Q 83. What shall be the applicable taxes if the service is partly received prior to the appointed date and partly received after the appointed date?

Ans. One must assess the point of taxation of such services. If the point of taxation of such services is prior to the appointed date, Service tax shall be chargeable and the same shall be eligible to be distributed as CGST credit under GST laws.

Provision for transfer of unutilized Cenvat Credit by taxable person having centralized registration under the earlier law (Section 191)

Q 84. What is the time period to carry forward the credit from the earlier law to the GST law?

Ans. An assessee shall be allowed to carry forward the credit from the earlier law to his electronic credit ledger to the extent the credit is furnished under the return filed under the earlier law. However, assessee must file the original and revised return within three months from the appointed day. Therefore, assessee shall not be allowed to carry forward the credit under the earlier law if he/she fails to file an original/ revised return within 3 months of the appointed day.

Q 85. Once the original return is filed, can the assessee revise the return?

Ans. Yes. The assessee may revise the original return filed under the earlier law. However, the time period of 3 months from the appointed date shall also apply to the revised return. Further, assessee shall not be allowed to claim more credit than the credit claimed in the original return.

Q 86. Can the entire credit claimed in the return filed under the earlier law be carry forwarded as credit under GST?

Ans. No. Only input credit which is eligible for set off under the earlier law as well as the GST laws shall be allowed to be carry forwarded.

Q 87. Can assesses having separate centralized registrations transfer credit among each other?

Ans. Assessee having separate centralized registration may transfer credit among each other if they function under a common PAN.

Q 88. Do the provisions of Section 191 relate to transfer of credit to CGST and SGST?

Ans. No. Section 191 deals only with transfer of credit to CGST

Tax paid on goods lying with agents to be allowed as credit (Sec 192)

Q 89. In the event the goods are lying with the agent on the appointed date, whether the credit shall be claimed by the principal or the agent?

Ans. The credit may be claimed by either the principal or the agent. However, if the agent claims the credit the conditions specified under Section 192 must be fulfilled.

Q 90. If the goods are lying with the agent and the agent wishes to claim the credit on such goods, what are the conditions that need to be fulfilled?

Ans. For the agent to claim the credit on goods lying with him on the appointed date, the conditions to be fulfilled are:

- The agent must be registered under the GST laws;
- The principal and the agent must declare the goods lying with the agent prior to the appointed date;
- The invoices for the goods must have been issued not before 12 months from the appointed date; and
- The principal must not have claimed the credit on such goods.

Q 91. Does Section 192 apply to CGST and SGST?

Ans. No. Section 192 applies only to SGST.

Tax paid on capital goods lying with agents to be allowed as credit (Section 193)

Q 92. Can an agent take credit of capital goods lying with him as on the appointed date?

Ans. Yes. An agent may take credit of capital goods lying with him on the appointed date subject to fulfillment of conditions as specified in Section 193.

Treatment of branch transfers (Section 194)

Q 93. Can an assessee take credit of input tax reversed on goods transferred prior to the appointed day?

Ans. No. input tax reversed on account of branch transfers cannot be re-claimed under GST.

Goods sent on approval basis returned on or after the appointed day (Section 195)

Q 94. If the goods are sent on approval before the appointed date but are rejected and returned after the appointed date, shall GST be charged on the return of such goods?

Ans. No. GST shall not be charged on the return of good sent on approval subject to the fulfillment of the following conditions;

- (a) The goods should have been sent on approval not earlier than 6 months from the appointed date;
- (b) The goods should have been returned within 6 months from the appointed date;

Q 95. If the goods are not returned within 6 months from the appointed date, can an extension be granted?

Ans. Yes. Competent authority may grant an extension of 2 months on sufficient cause being shown.

Q 96. If the goods are returned after 6 months from the appointed date, what are the consequences?

Ans. The goods returned shall be considered as a supply and appropriate taxes shall be charged by the person returning the goods.

Q 97. What is the liability of the person who sends the goods on approval in case goods are not returned within 6 months of the appointed date?

Ans. The person who has sent the goods on approval shall be liable to pay tax on such supply if the goods are not returned within 6 months from the appointed date.

Deduction of tax source (Section 196)

Q 98. In what circumstances, shall a supply attracting TDS provisions under the GST law be exempted from deducting tax at source?

Ans. The following conditions should be fulfilled to exempt a transaction from deduction of tax at source in the GST law;

- The transaction must be liable to TDS provisions under the earlier law; and
- The invoice for the transaction has been issued prior to the appointed date.

Q 99. In a transaction attracting TDS provisions under the earlier law and for which invoice has been raised prior to the appointed date, shall TDS need to be deducted under the GST laws if the consideration has been remitted after the appointed date?

Ans. No. Section 196 clearly indicates only two conditions to exempt a transaction from TDS provisions under the GST law as below:

- The transaction must be liable to TDS provisions under the earlier law; and
- The invoice for the transaction has been issued prior to the appointed date.

Transitional provisions for availing Cenvat credit in certain cases (Section 197)

Q 100. Where any CENVAT credit reversed under the earlier law on account of non-payment to the vendor, what was the period allowed to re-claim the credit in the earlier law and what are the changes in the new law?

Ans. In the earlier law, credit shall be required to be reversed if payment is not made within 3 months to the vendor and such credit may be re-claimed on payment to the vendor as and when the payment is made.

Under Section 197, credit reversed under the earlier law due to non-payment to the vendor shall be allowed to be reclaimed on payment to the vendor within 3 months from the appointed date.

MCQ**General Transitional Provisions (Section 165)**

Q 1. Which are the officers under the present law who will administer the State & Central GST?

- (a) VAT, Professional Tax & Entry Tax Officers
- (b) Excise and Service Tax officers
- (c) Customs officers
- (d) A & B respectively
- (e) All of the Above

Ans. (d) A & B respectively

Q 2. This transition provision enables the VAT Officers under the current tax regime (that are being subsumed into GST) to continue as _____

- (a) VAT Officers
- (b) GST Officers
- (c) Central Excise Officers
- (d) Income Tax Officers.

Ans. (b) GST Officers

Q 3. Can a Customs officer be appointed as GST officers?

- (a) No
- (b) Automatically they are transitioned as GST officer
- (c) Specific appointment by the GST Council is required
- (d) Specific appointment by the CGST Board is required

Ans. (d) Specific appointment by the CGST Board is required

Q 4. Will there be any change in the cadre ranking of the Central and State officers transitioned into GST?

- (a) Yes, they will receive a promotion
- (b) No, Status Q up will be maintained
- (c) May be
- (d) State Government and Central Government officers will be brought at par.

Ans. (b) No, Status Q up will be maintained

Migration of existing taxpayers to GST (Section 166)

Q 5. Does an existing Tax payer have to surrender the existing Registration certificates to obtain GST registration?

- (a) No, automatically he will receive final registration.
- (b) Yes, all registration certificates to be surrendered
- (c) Migrated to provisional registration subject to verification of documents
- (d) No, Provisional Registration is automatic

Ans. (d) No Provisional Registration is automatic

Q 6. Is PAN Mandatory for Migration to Provisional GST registration?

- (a) No
- (b) Yes
- (c) PAN Application is sufficient.
- (d) Waiver/Exemption can be obtained on application to the officer

Ans. (b) Yes, PAN is Mandatory

Q 7. What is the validity of the Provision registration Certificate issued to the existing dealers:

- (a) 6 months
- (b) 12 months
- (c) 3 months
- (d) 9 months

Ans. (a) 6 months

Q 8. Is a Composition dealer registered under the old law required to obtain Final GST Registration?

- (a) No, Old number will continue

- (b) Yes, mandatory for all Composition dealers
- (c) Yes, Subject to the turnover crossing the GST Turnover limit.
- (d) No, will be governed by old law.

Ans. (c) Yes, Subject to the turnover crossing the GST Turnover limit

Q 9. Will a person having multiple registration in various states receive single registration on Migration

- (a) Separate Registration would have to be obtained on migration for each State even for a single PAN number
- (b) Centralised Registration will be obtained for each PAN number across all States.
- (c) Separate Registration would have to be surrendered and fresh registration is required to be obtained.
- (d) Single registration with all locations across India disclosed as additional place of business can be obtained

Ans. (a) Separate Registration would have to be obtained on migration for each State even for a single PAN number

Q 10. If a dealer has multiple registrations in a State, will he obtain a consolidated GST registration or separate GST registrations

- (a) Single registration for each State will be granted without any exception
- (b) Two or more registrations for each State will be granted in case of separate business verticals
- (c) Any number of registrations can be obtained in each State
- (d) Rules have to be prescribed in this regard

Ans. (b) Two or more registrations for each State will be granted in case of separate business verticals

Amount of Cenvat credit forward in a return to be allowed as input tax credit (Section 167)

Q 11. What will be the amount carried forward as CGST/SGST from the earlier law and shown in the return filed for the period ending as on appointed date?

- (a) No amount will be carried forward from the earlier law
- (b) Amount which is admissible under earlier law but may not be admissible under GST

- (c) Amount which is admissible under GST but may not be admissible under earlier law
- (d) Amount which is admissible under both the GST and earlier law

Ans. (d) Amount which is admissible under both the GST and earlier law

Q 12. Which amount will be carried forward as CGST under GST law (Assuming applicability of GST from 1st April, 2017)?

- (a) Input tax credit as per the CENVAT Credit Register on 31st March, 2017
- (b) Input tax credit as per the Balance Sheet as on 31st March, 2017
- (c) Input tax credit as per the return furnished for the period ending 31st March, 2017
- (d) Input tax credit as per the last available return furnished under the earlier law

Ans. (c) Input tax credit as per the return furnished for the period ending 31st March, 2017

Q 13. Input tax credit as per the VAT law will be carried forward as:

- (a) CGST
- (b) SGST
- (c) IGST
- (d) CGST or SGST at the option of the supplier

Ans. (b) SGST

Q 14. Which among the following is not admissible as Opening CGST?

- (a) Krishi Kalyan Cess
- (b) Excise Duty
- (c) Service Tax
- (d) Swachh Bharat Cess

Ans. (d) Swachh Bharat Cess

Q 15. Who among the following persons are allowed to carry forward credit under the CGST/SGST law?

- (a) Composite dealers not required to take registration under GST law in view of minimum threshold turnover
- (b) Regular dealers under the earlier law and opting for Composite scheme under the GST law
- (c) Regular dealers under the earlier law and NOT opting for Composite scheme under GST law

- (d) Composite dealers under earlier law and continuing for Composite scheme under GST law

Ans. (c) Regular dealers under the earlier law and NOT opting for Composite scheme under GST law.

Q 16. Is there any requirement of a pre-approval or assessment or verification by the GST officers for transitioning the credit lying in balance in the VAT/ Cenvat Return into GST return?

- (a) Specific approval of the jurisdictional officer is required
- (b) Automatic
- (c) Detailed assessment / audit is mandatory for allowing credit
- (d) All credits availed upto one year prior to appointed date will be available

Ans. (b) Automatic, closing credit in the respective return would be automatically carried-forward into the electronic credit ledger under GST

Q 17. What happens to VAT credit which is not supported by statutory forms under the CST law?

- (a) Credit pertaining to sales which are not substantiated with necessary statutory forms will not be available
- (b) Credit is available on submission on Indemnity bond
- (c) Credit will be available whether or not statutory forms are submitted
- (d) Credit is not available in any circumstance

Ans. (a) Credit pertaining to sales which are not substantiated with necessary statutory forms will not be available

Q 18. Whether credit brought forward under the old law is eligible as input tax credit under GST law?

- (a) Yes, without any restrictions
- (b) Credit irregularly taken under the earlier law will also be available
- (c) Eligible credit under the earlier law will be available only if it is also admissible as input tax credit under the GST law
- (d) Eligible credit under the earlier law is available on a proportionate basis

Ans. (c) Eligible credit under the earlier law will be available only if it is also admissible as input tax credit under the GST law

Unavailed Cenvat credit on capital goods, not carried forward in a return, to be allowed in certain situations(Section 168)

Q 19. Which of the below is the condition for taking the unavailed CENVAT Credit on Capital Goods?

- (a) Unavailed CENVAT Credit should have been carried forward in the return

- (b) Unavailed CENVAT Credit should not have been carried forward in the return
- (c) Treatment of unavailed CENVAT Credit under the return is immaterial
- (d) Availed CENVAT Credit should not have been carried forward in the return

Ans. (b) *Unavailed CENVAT Credit should not have been carried forward in the return*

Q 20. Unavailed CENVAT Credit on Capital Goods will be carried forward as?

- (a) CGST
- (b) SGST
- (c) IGST
- (d) CGST or SGST at the option of the supplier

Ans. (a) *CGST*

Q 21. What is the condition for taking unavailed CENVAT Credit on Capital Goods?

- (a) The CENVAT Credit should have been admissible under earlier law but not under GST
- (b) The CENVAT Credit should have been admissible under GST but not under earlier law
- (c) The CENVAT Credit should not have been admissible under GST or the earlier law
- (d) The CENVAT Credit should have been admissible under both the earlier law and GST

Ans. (d) *The CENVAT Credit should have been admissible under both the earlier law and GST*

Q 22. If the unavailed Input Tax Credit on Capital Goods under the earlier law which has been subsequently availed under the GST law is found to be inadmissible as per the Proceedings of the Department, then what will be the course of action for the Department?

- (a) Such amount will be recovered under the GST law
- (b) Such amount will be recovered under the earlier law
- (c) Such amount cannot be recovered
- (d) Such amount may be recovered under the GST law or the earlier law at Department's option

Ans. (a) *such amount will be recovered under the GST law*

Credit of eligible duties and taxes in respect of inputs held in stock to be allowed in certain situations (Section 169)

Q 23. Which of the following will be allowed as credit under section (145)?

- (a) Input services
- (b) Total input purchased during the year
- (c) Capital goods
- (d) Inputs held in stock

Ans. (d) Inputs held in stock

Q 24. The inputs in stock should be used or intended to be used for making:

- (a) Taxable supplies
- (b) Exempt supplies
- (c) Either taxable or exempt supplies
- (d) Both taxable and exempt supplies

Ans. (a) Taxable supplies

Q 25. For credit to be allowable, invoices should not be issued earlier than:

- (a) Three months before the appointed day
- (b) Six months before the appointed day
- (c) Nine months before the appointed day
- (d) Twelve months before the appointed day

Ans. (d) Twelve months before the appointed day

Q 26. What is the time limit on the invoice within which the credit should be availed to be eligible for credit on the inputs?

- (a) Invoice should not be earlier than 12 months prior to the appointed date.
- (b) No time limit on the invoice
- (c) Invoice should not be earlier than 6 months prior to the appointed date.
- (d) Invoice should not be earlier than 15 months prior to the appointed date.

Ans. (a) Invoice should not be earlier than 12 months prior to the appointed date.

Q 27. Which among the following is not a necessary condition under section 169?

- (a) Inputs should be used for making taxable supplies under GST law
- (b) The benefit of credit of duties and taxes should be passed on to the recipient.
- (c) Should be in possession of the invoice or duty paying document
- (d) Should furnish stock holding statement as on appointed date

Ans. (d) Should furnish stock holding statement as on appointed date

Q 28. Which of the following are not eligible state taxes under the provisions of 169

- (a) Entry Tax
- (b) Central Sales Tax

- (c) Value Added Tax
- (d) Profession Tax
- (e) Luxury Tax, Entertainment Tax

Ans. (b) Central Sales Tax (d) Profession Tax and (e) Luxury Tax, Entertainment Tax

Q 29. Which of the following conditions for allowability of Input tax credit is correct?

- (a) Such amount should be allowable as credit under the earlier law except for the reason that the person was a composition taxpayer only
- (b) Such amount should be allowable as credit in the GST law only
- (c) Such amount should not be allowable in either of the laws
- (d) Such amount should be allowable as credit under both the earlier and GST law

Ans. (d) Such amount should be allowable as credit under both the earlier and GST law

Q 30. Which of the following will not be considered as eligible duties and taxes?

- (a) Additional duty leviable u/s 3(5) of the CTA
- (b) Basic Customs Duty
- (c) Central Excise
- (d) Service Tax

Ans. (b) Basic Customs Duty

Q 31. Which of the following will be allowable as credit under this section?

- (a) Inputs held in Finished goods in stock
- (b) Credit relating to Building
- (c) Ineligible Capital goods
- (d) Inputs consumed during the year

Ans. (a) Inputs held in finished goods in stock

Credit of eligible duties and taxes in respect of inputs held in stock to be allowed in certain situations (Section 170)

Q 32. After paying taxes on inputs under section 170, what will happen to the rest of the Input tax credit as per the electronic credit ledger?

- (a) Carry forward the rest of the credit
- (b) Credit kept in abeyance till the taxable opts for normal scheme once again
- (c) Credit lapses
- (d) Electronic credit ledger will freeze with the credit available

Ans. (c) Credit lapses

Q 33. The amount of credit of input tax will be paid by:

- (a) Debiting the electronic cash ledger mandatorily
- (b) Debiting the electronic credit ledger mandatorily
- (c) Debiting the electronic cash ledger or electronic credit ledger or both
- (d) None of the above

Ans. (c) *Debiting the electronic cash ledger or electronic credit ledger or both*

Q 34. A manufacturer of exempted and non-exempted goods or a service provider of exempted and taxable services are entitled to Cenvat credit under section 170 on

- (a) Inputs held in stock and inputs contained in semi-finished or finished goods held in stock on the appointed day, relating to exempted goods or services
- (b) Only goods directly pertaining to non-exempted goods or taxable services is eligible
- (c) Only proportionate credit based on the previous year turnover of non-exempted goods or taxable services is eligible
- (d) No credit is available in such cases

Ans. (a) *Inputs held in stock and inputs contained in semi-finished or finished goods held in stock on the appointed day, relating to exempted goods or services*

Credit of eligible duties and taxes in respect of inputs or input services during transit (Section 171)

Q 35. On the transition date which of the following credits are not available

- (a) Credit available in the return filed under the old law
- (b) Credit of goods in transit
- (c) Credit of incomplete services
- (d) Exempted goods in transit and taxable under the new GST law

Ans. (d) *Exempted goods in transit and taxable under the new GST law*

Q 36. Where supply has been made before the date of implementation of GST, no tax shall be Payable:

- (a) If tax/duty has been paid under the earlier law
- (b) If goods were exempted under the earlier law
- (c) If the goods were non-taxable under the earlier law
- (d) All of the above

Ans. (d) *All of the above*

Q 37. No tax will be payable on retention payment subsequent to appointed day, if:

- (a) Supplies have been made prior to the appointed day
- (b) Full amount of tax/duty has been paid before the appointed day
- (c) Both (a) and (b)

Ans. (c) *Both (a) and (b)*

Q 38. Which of the following is not a condition for availing credit on goods in transit or incomplete services

- (a) Credit should be taken in 30 days from the appointed date
- (b) Credit should be in the nature of eligible duties and taxes
- (c) Duty or tax should have been paid before the appointed date
- (d) Should be in possession of valid invoice or duty paid document
- (e) All of the above

Ans. (e) *All of the above.*

Q 39. The time limit of six months or the extended period shall be counted from?

- (a) Appointed date
- (b) Date of removal of inputs to job worker
- (c) Date of receipt of inputs by job worker

Ans. (a) *Appointed date*

Q 40. For the purpose of this section goods removed shall qualify as?

- (a) Semi-finished goods in the hands of manufacturer
- (b) Finished goods requiring further process
- (c) Inputs removed as such or after processing

Ans. (c) *Inputs removed as such or after processing*

Q 41. When should the invoice be received in order to fall under this section if the services are received before the applicability of GST and is pending for distribution on the date of GST?

- (a) Before the date of applicability of GST
- (b) After the date of applicability of GST
- (c) On the date of applicability of GST
- (d) The date of receipt of invoice is immaterial.

Ans. (d) *The date of receipt of invoice is immaterial*

Q 42. Where a supplier has made a sale of goods and deducted tax thereon under earlier law and issued invoice for the same before the appointed day but received payment after the appointed day:

- (a) No TDS is required to be deducted again under GST Act
- (b) TDS is be deducted again under GST Act

Ans. (a) No TDS is required to be deducted again under GST Act

Q 43. Declaration of inputs held in stock by job worker on behalf of manufacturer is to be filed by?

- (a) Manufacturer
- (b) Job Worker
- (c) Both (a) and (b)

Ans. (c) Both (a) and (b)

Credit of eligible duties and taxes on inputs held in stock to be allowed to a taxable person switching over from composition scheme (Sec 172)

Q 44. On which category of person will section 172 be applicable?

- (a) A person who opts for composition scheme under the GST law
- (b) A person who pays under the normal scheme under the GST law
- (c) A person who opts for composition scheme under the earlier law
- (d) A person who was exempt in the earlier law

Ans. (c) A person who opts for composition scheme under the earlier law

Q 45. On what portion of the stock does the taxable person need to pay tax?

- (a) Inputs held in stock only
- (b) Input within semi-finished/finished goods held in stock only
- (c) Both (a) and (b)
- (d) None of these

Ans. (c) Both (a) and (b)

Q 46. Which of the following is not a condition for a tax payer paying taxes under the composition scheme under the earlier law now switching to the regular scheme under the GST law

- (a) Said person is eligible for input tax credit of such inputs under the GST law
- (b) Said person is in possession of invoice or duty paid documents not earlier than 12 months preceding the appointed date

- (c) The said person is continuing to pay taxes under the composition scheme under section 9
- (d) The goods are intended to be used for making taxable supplies.

Ans. (c) *The said person is continuing to pay taxes under the composition scheme under section 9*

Q 47. Which of the following manufacturers are composition tax payers

- (a) Covered under compounded levy scheme
- (b) Covered under MRP valuation scheme
- (c) Covered under benefit of reduced excise duty rate
- (d) Covered based on production capacity

Ans. (a) *Covered under compounded levy scheme*

Exempted goods returned to the place of business on or after the appointed day (Section 173)

Q 48. What is the time limit within which the exempted goods shall be returned from the appointed day to continue availing the exemption under GST law?

- (a) Four months
- (b) Six months
- (c) Three months
- (d) Eight months

Ans. (b) *Six months*

Q 49. Which of the following is not a condition in respect of claiming exemption on return of exempted goods under section 173?

- (a) Goods should also be eligible for exemption under GST law
- (b) Goods should be returned within the period of 6 months
- (c) Goods should be destroyed after its receipt by the manufacturer/ trader
- (d) Goods should have been originally removed six months prior to appointed date

Ans. (a) & (c) *Goods should be destroyed after its receipt by the manufacturer/ trader*

Duty (Tax – in SGST Act) paid goods returned to the place of business on or after the appointed day (Section 174)

Q 50. What happens to duties and taxes paid on goods which are returned within six months from the appointed date?

- (a) Revise old return and claim reduction in output liability

- (b) Claim refund of taxes paid earlier on such goods
- (c) Claim re-credit of taxes paid under earlier law as input tax credit under GST law
- (d) Revise the first GST return and claim the credit of taxes paid under earlier law

Ans. (b) Claim refund of taxes paid earlier on such goods under earlier law

Q 51. The following is the difference between the provisions of section 173 and 174 of the GST law

- (a) Former deals with exempted goods and latter deals with dutiable goods
- (b) Former deals with exempted services and latter deals with taxable services
- (c) Former deals applicable only for manufacturers and latter is applicable only for service providers
- (d) Former places a condition of receipt of goods in registered place of business while latter does not have any such requirement

Ans. (a) Former deals with exempted goods and latter deals with dutiable goods

Inputs removed for job work and returned on or after the appointed day (Section 175); Semi-finished goods removed for job work and returned on or after the appointed day (Section 176) and Finished goods removed for carrying out certain processes and returned on or after the appointed day (Section 177)

Q 52. The process carried out on finished goods or testing done?

- (a) Amounts to Manufacture
- (b) Need Not amount to Manufacture
- (c) Results in different product
- (d) Results in change the use of product

Ans. (b) Need Not amount to Manufacture

Q 53. Which of the following is NOT a requirement for claiming the exemption from GST on job work?

- (a) Job work should be for a specified purposes such as processing, testing, repair, etc.
- (b) Goods should be returned after completion with six months or such extended period
- (c) Manufacturer should declare the details of inputs held in stock by the job worker on behalf of manufacturer

- (d) Job work should pay the GST even on returning the goods within the period of six months from appointed date

Ans. (d) Job work should pay the GST even on returning the goods within the period of six months from appointed date

Q 54. Who are the persons who should declare the stock of goods on job work to claim exemption under section 175?

- (a) Only job worker
- (b) Only principal manufacturer
- (c) Both (a) and (b)
- (d) Either (a) or (b)

Ans. (c) Both (a) and (b)

Q 55. Which of the following is difference between the provisions of section 175 and 176 of CGST/ SGST law?

- (a) Goods should be returned within six months from the appointed date
- (b) Goods can be sold/ removed/ exported directly to customer
- (c) Job worker and manufacturer have to both declare the stock of goods held on the appointed date
- (d) None of the above

Ans. (b) Goods can be sold/ removed/ exported from even the job-worker premises directly to customer only in the provisions of section 176 and not in section 175. Section 175 mandatorily requires that the goods are returned back to the principal manufacturer.

Q 56. What is the consequence of non-return of semi-finished goods within the specified period?

- (a) Job worker pays GST on return of goods
- (b) Principal Manufacturer pays back the input tax credit claimed on such goods
- (c) Principal manufacturer pays GST on return of goods
- (d) Job worker claims credit of goods received on job work

Ans. (b) Principal Manufacturer pays back the input tax credit claimed on such goods

Q 57. Which of the following statements is true in the context of section 175-177 of GST law?

- (a) Section 175 deals only with input sent for specified process which may or may not amount to manufacture
- (b) Section 176 deals only with semi-finished goods sent for manufacturing activity only

- (c) Section 177 deals with only finished goods sent for testing purposes
- (d) All of the above

Ans. (d) All of the above Section 178

Q 58. Which of the following is not necessary pre-requisite in respect of upward price revision during transition period?

- (a) Supplier should issue supplementary invoice or debit note
- (b) Such document should be raised within 30 days of price revision
- (c) Contract should have entered prior to appointed date
- (d) Goods should be removed or sold prior or services should be provided to appointed date
- (e) Supplier should revise earlier return and pay tax on differential

Ans. (e) Supplier should revise earlier return and pay tax on differential. The taxes should be paid as supply under GST law

Q 59. Which of the following is mandatory pre-condition in respect of downward price revision during transition period?

- (a) Recipient of credit note reduces his input tax credit
- (b) Supplier should revise earlier return and reduce tax liability
- (c) Supplier claims refund of downward revision
- (d) Recipient intimates his jurisdictional officer of such downward revisions

Ans. (a) Recipient of credit note reduces his input tax credit

Sections 179 – 181 [S-179- Pending refund claims to be disposed of under earlier law; S-180-Refund claims filed after the appointed day for goods cleared or services provided before the appointed day and exported before or after the appointed day to be disposed of under earlier law; S-181 - Refund claims filed after the appointed day for payments received and tax deposited before the appointed day in respect of services not provided]

Q 60. If the refund claim is partially rejected the amount would _____

- (a) lapse
- (b) be carried forward
- (c) be refunded

- (d) none of the above

Ans. (a) lapse

Q 61. Under what circumstances will the refund claim filed under the earlier law be rejected?

- (a) Refund claim is filed after appointed date
- (b) Credit is carried forward equivalent to refund amount
- (c) Refund claim is withdrawn
- (d) Refund claim will never lapse and shall be payable mandatorily paid by the department.

Ans. (b) Credit is carried forward equivalent to refund amount

Q 62. When can a refund claim be filed under provisions of section 180

- (a) Duty paid under the earlier law and exported prior to appointed date
- (b) Duty paid under the earlier law and exported after to appointed date
- (c) Duty paid after appointed date and exported after appointed
- (d) (A) and (B)

Ans. (d) (A) and (B)

Q 63. Which of the following is not true about claiming refund of service tax under section 181?

- (a) Service tax is deposited under earlier law
- (b) Provision of service is complete under earlier law
- (c) Refund of service tax would be in cash
- (d) Refund claim should be within the time limit under section 11B(2) of the Central Excise Act, 1944

Ans. (b) Provision of service is complete under earlier law

Claim of Cenvat credit to be disposed of under the earlier law (Section 182) and Finalization of proceedings relating to output duty or tax liability (Section 183)

Q 64. Which of the following is true in respect of events after the applicability of GST?

- (a) Proceedings under earlier law will be disposed of under the earlier law
- (b) Any default due to proceedings in the earlier law will be recovered in the earlier law
- (c) Proceedings under the earlier law will be disposed of under the new law

(d) Any refund due to the proceedings will be admissible as input tax credit

Ans. (a) Proceedings under earlier law will be disposed of under the earlier law

Q 65. How will the refunds occurring due to any proceedings under the earlier law relating to CENVAT Credit is treated under GST?

- (a) Such refund will be made in cash
- (b) Such refund will be allowed as input tax credit
- (c) Either a or b at the option of the taxable person
- (d) Either a or b at the option of the Department

Ans. (a) Such refund will be made in cash

Q 66. Section 182 will cover proceedings:

- (a) Relating to liability under GST
- (b) Relating to output duty liability under the earlier law
- (c) Relating to Cenvat credit or input tax credit under earlier law
- (d) All of the above

Ans. (c) Relating to Cenvat credit or input tax credit under earlier law

Q 67. The proceedings can involve:

- (a) Appeal
- (b) Review
- (c) Revision
- (d) All of the above

Ans. (d) All of the above

Treatment of the amount recovered or refunded in pursuance of assessment or adjudication proceedings (Section 184)

Q 68. Any amount of tax under the earlier law to be refunded to the claimant shall be paid by:

- (a) Cash
- (b) Adjustment against output tax
- (c) Both (a) and (b)
- (d) None of the above

Ans. (a) Cash

Q 69. Whether the amount paid as arrears of tax under the earlier law be admissible as input tax credit?

- (a) Yes
- (b) No

Ans. (b) No

Progressive or periodic supply of goods or services (Section 187)

Q 70. What are the conditions to pay tax under earlier law?

- (a) The consideration should have been remitted prior to the appointed date
- (b) Tax to be paid under the earlier law.
- (c) Both of the above
- (d) Invoice has been raised under the earlier law

Ans. (c) both of the above

Q 71. Whether consideration should have been fully paid in order for the supply to be taxed under the earlier laws?

- (a) Consideration to be fully paid
- (b) Consideration may be partly paid
- (c) Consideration may be partly paid or fully paid prior to the appointed day
- (d) Consideration is not a relevant criteria for determination

Ans. (c) Consideration may be partly paid or fully paid prior to the appointed day

Taxability of supply of services in certain cases (Section 188)

Q 72. Section 188 specifies that the supply shall be taxed under the earlier laws if the point of taxation arises prior to the appointed date. To check the point of taxation, reference is to be made to which of the following:

- (a) The Point of Taxation Rules, 2011
- (b) The GST laws
- (c) Service Tax Rules
- (d) CENVAT Credit Rules

Ans. (a) The Point of Taxation Rules, 2011

Provision for transfer of unutilized Cenvat Credit by taxable person having centralized registration under the earlier law (Section 191)

Q 73. Once the original return is filed, what is the time frame within which the assessee can revise the said return?

- (a) 3 months
- (b) 6 months
- (c) No option for revision
- (d) No deadline for revision

Ans. (a) 3 months

Q 74. Which type of credit claimed in the return filed under the earlier law may be allowed to be carried forward as credit under GST?

- (a) All Credits claimed
- (b) No carry forward of credit allowed. Available credit maybe claimed as refund.
- (c) Only input credit which is eligible for set off under the earlier law as well as the GST laws
- (d) None of the above

Ans. (c) Only input credit which is eligible for set off under the earlier law as well as the GST laws

Q 75. Condition for assesses having separate centralized registrations transfer credit among each other?

- (a) If they operate under a single business vertical
- (b) If they function under a common PAN.
- (c) If they are held by a common Holding Company
- (d) None of the above

Ans. (b) If they function under a common PAN

Tax paid on goods lying with agents to be allowed as credit (Sec 192)

Q 76. If the goods are lying with the agent and the agent wishes to claim the credit on such goods, which of the following conditions that need to be fulfilled?

- (a) The agent must be registered under the GST laws and the principal and the agent must declare the details of stock of goods lying with the agent prior to the appointed date;
- (b) The invoices for the goods must have been issued not before 12 months from the appointed date; and
- (c) The principal must not have claimed the credit on such goods.
- (d) All of the above

Ans. (d) All of the above

Treatment of branch transfers (Section 194)

Q 77. Can an assessee take credit of input tax reversed on goods transferred prior to the appointed day?

- (a) Yes, only if credits are in relation to goods liable to GST.
- (b) Yes, only if the assessee has paid all taxes payable by him
- (c) Both of the above
- (d) No. input tax reversed on account of branch transfers cannot be re-claimed under GST.

Ans. (d) No. input tax reversed on account of branch transfers cannot be re-claimed under GST.

Goods sent on approval basis returned on or after the appointed day (Section 195)

Q 78. If the goods are sent on approval before the appointed date but are rejected and returned after the appointed date, shall GST be charged on the return of such goods.

- (a) No, only if the goods have been sent on approval not earlier than 6 months from the appointed date
- (b) No, only if the goods have been returned within 6 months from the appointed date
- (c) Both of the above
- (d) Yes, GST is to be charged

Ans. (c) Both of the above

Q 79. If the goods are not returned within 6 months from the appointed date, can an extension be granted?

- (a) Yes. Competent authority may grant an extension of 2 months on sufficient cause being shown.
- (b) No extension in such a scenario
- (c) Yes. Intimation has to be given to the concerned authority
- (d) None of the above

Ans. (a) Yes. Competent authority may grant an extension of 2 months on sufficient cause being shown.

Q 80. If the goods are returned after 6 months from the appointed date, what are the consequences?

- (a) The goods returned shall be considered as a supply and appropriate taxes shall be charged by the person returning the returns.
- (b) No consequences.

- (c) No consequences, only if duly intimated to the department
- (d) Mandatory penalty shall be levied.

Ans. (a) The goods returned shall be considered as a supply and appropriate taxes shall be charged by the person returning the returns.

Q 81. What is the liability of the person who sends the goods on approval in case goods are not returned within 6 months of the appointed date?

- (a) The person who has sent the goods on approval shall be liable to pay tax on such supply if the goods are not returned within 6 months from the appointed date.
- (b) Penalty shall be levied
- (c) No Liability
- (d) None of the above

Ans. (a) The person who has sent the goods on approval shall be liable to pay tax on such supply if the goods are not returned within 6 months from the appointed date.

Deduction of tax source (Section 196)

1. In what circumstances shall a supply attracting TDS provisions under the GST law be exempted from deducting tax at source:
 - (a) The transaction must be liable to TDS provisions under the earlier law
 - (b) The invoice for the transaction has been issued prior to the appointed date.
 - (c) Both of the above
 - (d) Consideration must have been received prior to appointed date

Ans. (c) Both of the above

Integrated Goods and Services Tax (IGST)

Chapter I

Principles for Determining Supply of Goods and/or Services in the course of Inter-State Trade or Commerce

FAQ

Supply of goods and / or service in the course of inter-state trade or commerce (Section 3)

Q 1. When is supply of goods considered as supply in the course of inter-State trade or commerce?

Ans. Supply of goods will be considered as inter-State supply, if the location of the supplier and place of supply are in different States. This is subject to provisions contained in section 7 of the Revised Model IGST Law.

Q 2. When is supply of services considered as supply in the course of inter-State trade or commerce?

Ans. Supply of services will be considered as inter-State supply, if the location of the supplier and place of supply are in different States. This is subject to provisions contained in section 9 of the Revised Model IGST Law.

Q 3. What is the meaning of location of supplier?

Ans. Location of supplier of goods: The term location of supplier of goods has not been defined in the Revised Model IGST Law. Therefore, the location of goods may have to be considered as the location of supplier. Since every taxable person is required to take registration and pay tax in respect of every taxable supply, thus the 'location of goods' becomes the 'location of supplier'.

Location of supplier of service: Location of supplier of service is defined under section 2(18) of the Revised Model IGST Law as under:

- (a) where a supply is made from a place of business for which registration has been obtained, the location of such place of business;

- (b) where a supply is made from a place other than the place of business for which registration has been obtained, that is to say, a fixed establishment elsewhere, the location of such fixed establishment;
- (c) where a supply is made from more than one establishment, whether the place of business or fixed establishment, the location of the establishment most directly concerned with the provision of the supply; and
- (d) in absence of such places, the location of the usual place of residence of the supplier

Q 4. Whether Supply of goods in the course of import into India be treated as inter-State trade or commerce and what is the place of supply of goods in the course of import into India?

Ans. Supply of goods in the course of import into territory of India till the goods cross the customs frontiers of India will be treated as inter-State trade or commerce.

Further, Customs frontiers of India means the limits of the area of a customs station as defined in section 2 of the Customs Act, 1962 (52 of 1962) in which imported goods are ordinarily kept before clearance by customs authorities.

Furthermore, Customs station is defined under section 2 of the Customs Act, 1962 to mean any customs port, customs airport or land customs station.

Moreover, Section 8 of the Revised Model IGST Law provides that the place of supply of goods imported into India shall be the location of the importer.

Q 5. Whether the goods supplied from custom bonded warehouse is considered as supply in the course of import into India?

Ans. Goods kept in customs bonded warehouse are goods pending clearance by the customs authorities and hence would be considered as lying outside the customs frontiers of India. Therefore, goods supplied from custom bonded warehouse would be considered as supply in the course of import into India and treated as supply in the course of inter-State trade or commerce.

Q 6. Whether IGST will apply on supply of service in the course of import into India? What will be the place of supply in such case? Give Example

Ans. Supply of service in the course of import into the territory of India will be treated as supply in the course of inter-State trade or commerce is liable to IGST. Further, Section 10 of the Revised Model IGST Law provides the place of supply where the location of the supplier or the location of the recipient is outside India. Hence, the place of supply in case of supply of service in the course of import into India is to be determined in terms of Section 10 thereof.

Example– Annual maintenance contract entered by a Company outside India for maintenance of goods located in India.

Q 7. What is the place of supply, if the supplier of goods is located in Bangalore and the recipient of goods being an SEZ unit is in Bangalore?

Ans. Supply of goods to or by a SEZ developer or an SEZ unit, shall be deemed to be a supply of goods and/or services in the course of inter-state trade or commerce. The location of supplier or recipient is irrelevant. In the given case, though supplier and recipient are located in the same State (i.e. Karnataka), the place of supply of goods to a SEZ unit will be treated as inter-State supply.

Further, in terms of Section 8 of the Revised Model IGST Law, the place of supply of goods exported from India shall be location outside India, and supply to SEZ being deemed export, place of supply in the instance case will be where recipient of goods being an SEZ unit is located.

Supplies of goods and/or services in the course of intra-State trade or commerce (Section 4)

Q 9. When is supply of goods considered as supply in the course of intra-State trade or commerce?

Ans. Supply of goods will be considered as intra-State supply, if the location of the supplier and place of supply are in the same State. This is subject to provisions contained in section 7 of the Revised IGST Law.

Further, intra-State supply of goods shall not include supply of goods to or by a SEZ developer or to or by an SEZ unit and supply of goods brought into India in the course of import till they cross the customs frontiers of India

Q 10. When is supply of service considered as supply in the course of intra-State trade or commerce?

Ans. Supply of service will be considered as intra-State supply if the location of the supplier and place of supply are in the same State. This is subject to provisions contained in section 9 of the Revised Model IGST Law.

Further, intra-State supply of services shall not include supply of services to or by a SEZ developer or to or by an SEZ unit

MCQ

Q 1. Which of the following is an inter-State supply?

- (a) Supplier of goods located in Delhi and recipient of goods SEZ located in Delhi
- (b) Supplier of goods located in Delhi and place of supply of goods in Jaipur
- (c) Supplier of goods located in Delhi and recipient of goods SEZ located in Chandigarh
- (d) All the above

Ans. (d) all the above

Q 2. Which of the following is an intrastate supply?

- (a) Supplier of goods located in Delhi and recipient of goods SEZ located in Delhi
- (b) Supplier of goods located in Delhi and place of supply of goods in Jaipur
- (c) Supplier of goods located in Delhi and place of supply of goods in Delhi
- (d) All the above

Ans. (c) Supplier of goods located in Delhi and place of supply of goods in Delhi

Q 3. Which of the following transaction is inter-state supply of goods involving movement of goods?

- (a) Location of supplier is in Bangalore and location of recipient is in Mumbai
- (b) Location of supplier is in Bangalore and place of supply is Mumbai
- (c) Location of supplier and place of supply is Bangalore
- (d) None of the above

Ans. (b) Location of supplier is in Bangalore and place of supply is Mumbai

Q 4. Supply of goods in the course of import into territory of India is

- (a) Intrastate supply
- (b) Inter-State supply
- (c) Export
- (d) Supply in the course of inter-state trade or commerce

Ans. (d) Supply in the course of inter-state trade or commerce

Chapter - II

Levy and Collection of Tax

FAQ

Levy and Collection of IGST (Section 5)

Q 1. On what transactions IGST shall be levied?

Ans. Transactions of supplies of goods and/or services in the course of inter-State trade or commerce

Q 2. On what value IGST shall be levied?

Ans. The value of the transaction shall be determined under Sec 15 of the CGST Act, 2016

Q 3. Is there any rate prescribed under IGST?

Ans. Rate shall be notified by Central Government not exceeding 28%

Q 4. Who shall decide the rate to be notified?

Ans. Central government shall decide the rates on recommendation of the GST Council

Q 5. Who is responsible to pay the GST?

Ans. Generally, the provider of supply is liable to pay GST, in certain cases the responsibility is transferred on the recipient of service on reverse charge basis.

Q6. Is reverse charge mechanism applicable only to services?

Ans. No, Reverse charge applies to supplies of both goods and services.

Q 7. How will IGST be levied on Imports?

Ans. Supply of goods/services in the course of import into the territory of India shall be deemed to be a supply of goods/services in the course of inter-state trade or commerce and therefore, IGST shall be levied on all such imports

Q8. When is the levy of IGST on imports being imposed?

Ans. IGST shall be levied and collected in accordance with the provisions of Sec 3 of the Customs Tariff Act, 1975, at the point when custom duties are levied on the said goods

under Sec 12 of the Customs Act, 1962, on a value as determined under the first mentioned Act.

Q 9 What is the levy on an e-commerce operator?

Ans. Central Government on recommendation of Council shall specify category of services which shall be paid by the electronic commerce operator if such services are supplied through it. All provisions of the Act shall apply to such ecommerce operators.

Q 10. What's the implication if e-commerce operator doesn't have a physical presence in India?

Ans. In such situations, any person representing the e-commerce operator for any other purpose shall be liable.

Q 11. What if both e-commerce operator and representative have a physical presence in India?

Ans. In such situations, such e-commerce operator shall appoint a person in the taxable territory for the purpose of paying tax and such person shall be liable to pay tax.

Q 12. How does GST apply when 2 branches of a company are located viz Karnataka and Tamil Nadu and there are movement of goods/services between the branches?

Ans. In accordance with Explanation 1(ii) to sub-sec 3 of Section 5 of IGST Act, an establishment of a person in a State and any of his other establishments outside the state, shall be treated as distinct persons. Considering the above, branch in State of Karnataka shall be treated as a different entity from that of branch in the State of Karnataka and levy shall get attracted accordingly.

Q13. How does GST apply when there is a Head office in Bangalore (in India) and branch in say, Singapore and there is a service rendered by branch to Head office?

Ans. Explanation 1 to Section 5 of the Revised Model IGST Law clearly states that '*an establishment of a person in India and any of his other establishments outside India shall be treated as establishments of distinct persons.*' In this case the service rendered from Singapore branch to head office in Bangalore shall be treated as distinct entities for the purpose of levy.

Further, Section 3 states that supply of services in the course of import into the territory of India shall be deemed to be a supply of services in the course of inter-State trade or commerce. And according to Section 5, Integrated Goods and Services Tax is levied on all supplies of goods and/or services made in the course of inter-State trade or commerce

Therefore, in the instance case, IGST will be levied on service rendered from Singapore branch to head office in Bangalore

Power to grant exemption (Section 6)

Q 14. Are all exemptions from tax on intrastate supplies apply to interstate supply of same goods or services as well?

Ans. Unless otherwise specified all exemption for intrastate supplies would apply for inter-State supplies as well.

Q 15. How can exemption to service be provided by Central Government?

Ans. 1. Exemption could be generally provided with or without conditions. If provided without any condition i.e. absolute exemption, person shall not pay any tax.

2. Exemption could be specially provided, owing to exceptional circumstances to be stated in the order granting such exemption

Q 16. Can an explanation to the exemption notification be issued by Central Government be issued at any time?

Ans. No. Explanation to notification be issued within one year from the date of the original notification and such explanation shall be considered to have been always the intention of the law and its applicability would be retrospective.

Q17. When shall an exemption come into force?

Ans. Any exemption shall come into force on the day–

1. On publication of said exemption in official gazette or from any date subsequent to the date of issue of notification as may be specified and

2. On the date made available on the official website of the Central Government.

Chapter III

Place of Supply of Goods and/or Services

FAQ

Place of supply of goods other than supply of goods imported into, or exported from India (Section 7)

Q 1. What is the place of supply where movement of goods are involved?

Ans. As per section 7(2) of the Revised Model IGST Law, place of supply involving movement of goods shall be the location of the goods where movement of goods terminates for delivery to the recipient.

Illustration

Location of supplier	Delivery of goods	Place of supply	Nature of supply	Tax
Karnataka	Andhra Pradesh	Andhra Pradesh	Inter-state	IGST
Karnataka	Karnataka	Karnataka	Intra-state	SGST/CGST

Q 2. What is the place of supply where goods are delivered to a person on the direction of a third person?

Ans. As per section 7(3) of the Revised Model IGST Law, if movement is at the instance of the third person to a recipient (by way of instruction or transfer of documents of title to goods or otherwise), the place of supply will be principal place of business of third person (i.e. address in Registration Certificate). A pictorial diagram is depicted to explain the same

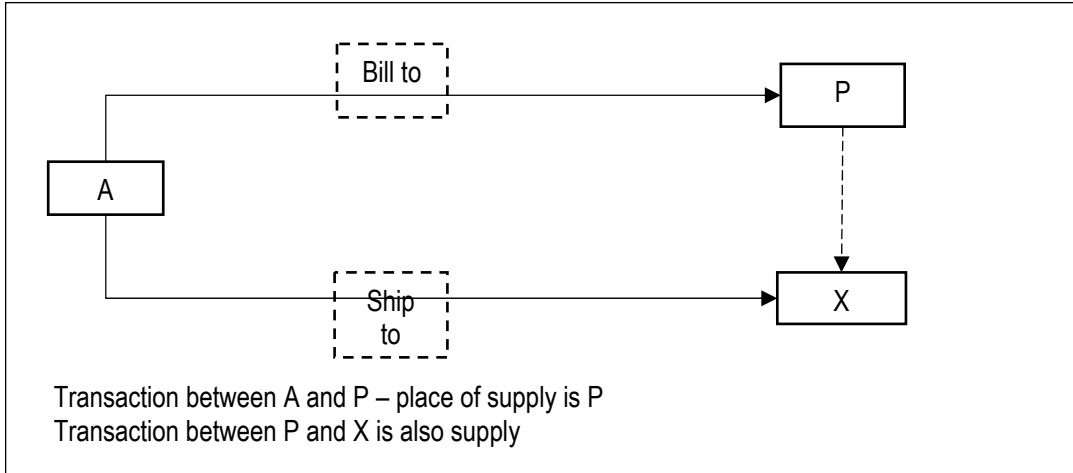

Further, illustrations are provided below to explain the same

- (a) Transaction between supplier (A in above diagram) and third party (P in the above diagram).

Compare column 1 and 2

Location of supplier (1)	Location of third party (2)	Delivery of Goods (3)	Place of supply	Nature of Supply	Applicability
Karnataka	Kerala	Tamil Nadu	Kerala	Inter-state	IGST
Karnataka	Karnataka	Kerala	Karnataka	Intra-state	SGST/CGST
Karnataka	Kerala	Karnataka	Kerala	Inter-state	IGST
Karnataka	Kerala	Kerala	Kerala	Inter-state	IGST

- (b) Transaction between third party (P in the above diagram) and person actually receiving the goods (X in the above diagram). Compare column 2 and 3

Location of supplier (1)	Location of third party (2)	Delivery of Goods (3)	Place of supply	Nature of Supply	Applicability
Karnataka	Kerala	Tamil Nadu	Tamil Nadu	Inter-state	IGST
Karnataka	Karnataka	Kerala	Kerala	Inter-state	IGST
Karnataka	Kerala	Karnataka	Karnataka	Inter-state	IGST
Karnataka	Kerala	Kerala	Kerala	Intra-state	SGST / CGST

Q 3. What is the place of supply where movement of goods is not involved?

Ans. Where supply does not involve movement of goods, the place of supply will be the location of goods at the time of delivery to the recipient. Neither in the CGST Act nor in the IGST Act, the 'location of supplier of goods' has not been defined. Therefore, the location of goods where they are ready to be supplied can be understood to be the location of supplier. Considering that location of supplier will be location of goods, in this type of transaction there will not be any inter-State supply since the location of supplier and place of supply will be in the same State.

Example for this would be a case where the job worker develops a mould for the production of goods for the principal and retains the mould in his place itself for production of goods. The mould developed by the job worker is sold to the principal but the same are retained by the job worker without causing the movement of mould from job worker premise to principal premise. In this case the place of supply would be job worker premise.

Q 4. What is the place of supply in case of assembly or installation of goods at site?

Ans. The place of supply of goods in case of assembly or installation of goods will be the place of installation or assembly.

Q 5. What is the place of supply in case of goods / food products sold on aircraft?

Ans. The place of supply in case of goods taken onboard for consumption in aircraft, is the place or location at which such goods are taken on board. For example, if an aircraft departs from Bangalore to Mumbai after taking onboard food for consumption on board, the place of supply will be Bangalore.

Q 6. In case of ambiguity, whether State Government can give directions to determine place of supply of goods?

Ans. No. In case of any ambiguity where place of supply cannot be determined as provided in Section 7(2) to 7(6) of the Revised Model IGST Law, the place of supply of goods will be determined by the Central Government based on the recommendation of the GST Council.

Place of supply of goods imported into, or exported from India (Section 8)

Q7. What do you mean by importation of goods into India?

Ans. Section 2 (10) of the Revised Model IGST Law defines import of goods to mean bringing goods into India from a place outside India.

Q 8. What is the territory of India for the purpose of IGST?

Ans. Section 2(12) of Revised Model IGST Law defines India as under

“India” means: -

- (a) the territory of the Union as referred to in clauses (2) and (3) of Article 1 of the Constitution;
- (b) its territorial waters, continental shelf, exclusive economic zone or any other maritime zone as defined in the Territorial Waters, Continental Shelf, Exclusive Economic Zone and other Maritime Zones Act, 1976 (80 of 1976);
- (c) the seabed and the subsoil underlying the territorial waters;
- (d) the air space above its territory and territorial waters; and
- (e) the installations, structures and vessels located in the continental shelf of India and the exclusive economic zone of India, for the purposes of prospecting or extraction or production of mineral oil and natural gas and supply thereof;

Q 9. In case of importation of goods into India what is the location of supply of goods?

Ans. The location of the importer is the place of supply of goods in case of importation of goods into India. It may be noted that importer has not been defined in the Revised Model IGST Law. Therefore, the meaning given under Customs Act, 1962 will have to be taken. As per section 2(26) of the Customs Act, 1962 "importer", in relation to any goods at any time between their importation and the time when they are cleared for home consumption, includes any owner or any person holding himself out to be the importer.

Q 10. In case of export of goods from India, what is the location of supply of goods?

Ans. The location of supply of goods exported from India shall be the location outside India.

Place of supply of services where the location of supplier of service and the location of the recipient of service is in India (Section 9)

Q 11. What is the place of supply of services?

Ans. Section 9 of the Revised Model IGST Law lays down the principles for identifying the place of supply of services in case of certain specified services. In respect of services other than the specified services the place of supply of service would be as under

- (a) Where the service is provided to registered person place of supply shall be location of such person

- (b) Where the service is provided to a person other than registered person, the place of supply shall be - (i) location of the recipient where the address on record exists
(ii) location of the supplier of services in other cases

Q 12. What is the place of supply of service in relation to an immovable property?

Ans. Section 9 (4) (a) of Revised Model IGST Law provides that any service provided directly in relation to an immovable property including services provided by architects, interior decorators, surveyors, engineers and other related experts or estate agents, any service provided by way of grant of rights to use immovable property or for carrying out or coordination of construction shall be the location at which the immovable property is situated.

Illustration - If Mr. A of Ahmadabad, is constructing a house in Mumbai and appoints Mr. B of Delhi to provide architectural services with regard proposed construction of house located in Mumbai, then the place of supply of such architectural services shall be Mumbai.

Q 13. What is the place of supply of accommodation services? Give an example.

Ans. As per Section 9(4) (b) of the Revised Model IGST Law, the location of the hotel, inn, guesthouse, home stay, club or campsite or a houseboat or vessel, shall be the place of supply of service in relation to such accommodation service. In case, the accommodation service is provided for multiple locations situated in different states or the vessel or boat located in more than one state at a time of supply of service, then the value of the supply of service shall be treated as made in each of the States in proportion to the value for services separately collected or determined in the terms of the contract or arrangement entered into. In absence of such contract or agreement, on such other reasonable basis as would be prescribed.

For example, YOYO Rooms, based out of Bangalore, takes reservation for accommodation in its hotels across India from ABC airlines, based out of New Delhi, for overnight stay of its crew members. The place of accommodation services shall be the location of the hotel where the crew members have stayed. In case, the agreement between YOYO rooms and ABC airlines is per night per room basis, then the value of service separately collected for each hotel shall be treated as the value of service for the respective state. In case, the agreement between YOYO rooms and ABC airlines is on a lump sum basis for a month then the place of supply shall be determined as may prescribed in rules.

Q 14. What will be the place of supply for restaurant and catering services?

Ans. The place of supply for restaurant and catering services shall be the location where the services are actually performed. Section 9(5) of the Revised Model IGST Law provides that

place of supply of service shall be location here the services are actually performed in respect of restaurant and catering services, personal grooming, fitness, beauty treatment, health services including cosmetic and plastic surgery

Example, if Mr X, resident of Mumbai, goes to Bangalore for plastic surgery then the place of supply of plastic surgery services shall be Bangalore.

Q 15. What will be the place of supply of training services?

Ans. Section 9(6) of the Revised Model IGST Law provides that when a training service is provided to a registered person, the location of such registered person shall be the place of supply of training services. In case the service is provided to a person other than a registered person, then the place of supply shall be the location where the services are actually performed.

Example - If Mr. A, a resident of Bangalore, conducts training for employees of Software Ltd, a company based out of New Delhi, in Shimla Resort located in Shimla, then the place of supply of training service shall be New Delhi if Software Ltd is a registered person. If Software Ltd is not a registered person, then to place of supply of training service shall be Shimla.

Q 16. What will be the place of supply of services for admission to sporting events?

Ans. Section 9 (7) of the Revised Model IGST Law provides that the place of supply of services provided by way of admission to cultural, artistic, sporting, scientific, educational, or entertainment events or amusement park or any other place and services and ancillary thereto, shall be the place where the event is actually held or where the park or such other place is located. Hence, the services in relation to admission to a sporting event shall be the location where the event is actually held.

Example, Book My Ticket Private Limited, a company based out of Bangalore providing online ticketing services for admission to various events, sells online tickets for IPL tournament to be held across India, then the place of supply of services for admission to each cricket match shall be the location where the match is actually played.

Q 17. What will be the place of supply for services in relation to organizing events?

Ans. Section 9(8) of the Revised Model IGST Law provides that services in relation to organization of events when provided to a registered person shall be the location of such person. If the service is provided to a person not registered, then the place of supply shall be the place where event is actually held.

If the events are held in more than one State and consolidated amount is charged for supply of services relating to such event, then the place of supply of services shall be

taken as being in each of the State in proportion to the value of services so provided in each State as ascertained from the terms of the contract or agreement entered into in this regard. In absence of such contract or agreement then the place of supply shall be determined as may prescribed in rules.

Example, Cars Limited, an automobile company based out of Bangalore, appoints Events Private Limited, a company based out of Mumbai providing event organization services, to provide services for organizing an event of launching their new vehicle in Indian market. The launch event is organized at Mumbai, Delhi, Calcutta, Chennai by the Event Private Limited. The place of supply of organizing such events shall be the location of Cars Limited, that is Bangalore, if Cars Limited is a registered person.

If Cars Limited is not a registered person, then the place of supply of such event organization services shall be the location where the events are actually held.

Q 18. What will be the place of supply of sponsorship services?

Ans. Assigning of sponsorship to any of the cultural, artistic, sporting, scientific, educational or entertainment event shall be the location of the registered person (recipient). If the event is organized for an unregistered person, then the assignment of sponsorship shall be the location where the event is actually held.

Q 19. What will be the place of supply of services in relation to a sporting event organized/held outside India?

Ans. Section 9(8) of the Revised Model IGST Law provides that if an event is held outside India, the place of supply shall be the location of the recipient.

Example, if an IPL cricket match is played in South Africa, then the place of supply of service in relation to organizing the cricket match shall be the location of IPL limited.

Q 20. What is the place of supply of services by way of transportation of goods?

Ans. Section 9(9) of the Revised Model IGST Law provides that services by way of transportation of goods provided to a registered person shall be the location of registered person. Such services if provided to a person other than a registered person, shall have place of supply and the location at which such goods are handed over for their transportation.

Example, if Express limited, a goods transport company based out of Chennai, provides transportation services to Cars Limited, an automobile company based out of Bangalore, for movement of their cars from the warehouse of Cars Limited at Silvassa (Union Territory) to Delhi, then the place of supply of transportation services shall be Bangalore if

Cars Limited is a registered person. If Cars Limited is not a registered person, then the place of supply of transportation services shall be Silvassa.

Q 21. What is the place of supply for services of passenger transportation?

Ans. Section 9(10) of the Revised Model IGST law provides that place of supply of passenger transportation services to a registered person shall be the location of such registered person. If such services are given to a person other than a registered person, then the place of supply of passenger transportation services shall be the place where the passenger embarks (begins) on the conveyance for a continuous journey.

Example, if Mr. A, a registered taxable person based out of Mumbai, purchases air ticket from Airlines Ltd, an airline company based out of Chennai, for travel from New Delhi to NEW YORK via Dubai, then the place of supply of passenger transportation shall be Mumbai. If Mr. A is not a registered person then the place of supply of passenger transportation shall be New Delhi.

Q 22. What is the place of supply of services provided on board a conveyance such as aircraft?

Ans. Section 9(11) provides that the place of supply of services on board a conveyance such as vessel, aircraft, train or motor vehicle will be the location of the first scheduled point of departure of that conveyance for the journey.

Example: Palace on wheels, a train running from Jaipur to Kanyakumari, provides on-board entertainment services to its passengers, then the place of supply of such on-board entertainment services shall be Jaipur (first scheduled point of departure). For return journey, the place of supply shall be Kanyakumari.

Q 23. What is the place of supply for the telecommunication services?

Ans. Section 9(12) of the Revised Model IGST Law provides for determination of place of supply for the telecommunication services as under

(a) In case of services by way of fixed telecommunication line, leased circuits, internet leased circuits, cable or dish antenna, shall be the location where such installation for receipt of such services is done. Example, if Mr. A, resident of Bangalore purchases dish antenna from Tata sky, a company providing DTH cable services based out of Mumbai, then the place of supply of DTH services shall be the location where the dish antenna is installed that is Bangalore.

(b) In case of postpaid mobile connection services, the place of supply of telecommunication services shall be the billing address of the recipient or services on record of service provider. Example, Mr. A, resident of Bangalore, takes services from Airtel Limited, a company based out of New Delhi, for he is postpaid

mobile connection then, the place of supply of services in relation to the postpaid mobile connection shall be the billing address of Mr. A as per the records of Airtel Limited, regardless of where Mr. A utilises the mobile services.

- (c) In case of prepaid mobile connection services, the place of supply of telecommunication services shall be the location of the selling agent or a reseller or a distributor of SIM card or recharge voucher as per the record of supplier. Example, if Mr. A, a resident of Bangalore has a prepaid mobile connection from Airtel Limited and while travelling to Mumbai, he purchases a recharge coupon from a local distributor, then the place of supply of such services would be the location of the local distributor.
- (d) In case, the vouchers are not sold by aforementioned persons, then the place of supply of services shall be the location where such prepayment is received or such vouchers are sold by any other person to the final subscriber.
- (e) In case where address of the recipient as per records of the supplier of service is not available, the place of supply shall be location of the supplier of service.
- (f) In case of prepaid services, if the recharge is done through Internet banking or electronic mode of payment (online), then the location of the recipient of services on record of the supplier of services shall be the place of supply of such service.

Q 24. What will be the place of supply of leased line services when the leased circuit is installed at more than one location/State?

Ans. As per Explanation to Section 9(12) (d) of Revised Model IGST Law, if leased circuit is installed in more than one state and a consolidated amount is charged for supply of services relating to such circuit, the place of supply of such services shall be taken as being in each of the States in proportion to the value of services so provided in each State as ascertained from the terms of the contract or agreement entered into in this regard. In absence of such contract or agreement then the place of supply shall be determined as may prescribed in rules. Example, if Software Ltd, a company based out of Bangalore procures services of leased circuit lines for its branches in Mumbai and Calcutta and Chennai from DTH limited, a company based out of New Delhi, then the place of supply of service of leased circuit lines shall be proportionately at each branch where the installation is done. In case, software Ltd pays a lump sum amount for the leased circuit lines services of all branches, then the apportionment between states shall be done on reasonable basis as may be prescribed in this regard.

Q 25. What will be the place of supply of banking services and other financial services, stockbroking services?

Ans. As per Section 9(13) of the Revised Model IGST Law, the place of supply of banking services shall be the location of the recipient of service as available on the records of the supply of services. If the location of recipient of service is not on records of the supplier, the place of supply shall be the location of supplier of service.

Example, if Mr. A, a resident of Mumbai opens a bank account in Mumbai with Bank Ltd, and submits his residence address in Mumbai that the place of supply of banking services shall be Mumbai.

If Mr. B goes to bank in Bangalore not having an account with the bank to take a demand draft, the place of supply shall location of the supplier i.e. bank in Bangalore issuing the demand draft.

Q 26. What is the place of supply of insurance services?

Ans. As per Section 9(14) of the Revised Model IGST Law, insurance services provided to a registered person shall be the location of such registered person. In case of insurance services provided to a person other than a registered person, place of supply shall be location of the recipient of services on record of the supplier of services.

Place of supply of services where the location of the supplier or the location of the recipient is outside India (Section 10)

Q 27. What is the place of supply of services where the location of the supplier or the location of the recipient is outside India?

Ans. Section 10 of the Revised Model IGST Law lays down the principles for identifying the place of supply of services in case of certain specified services. In respect of services other than the specified services the place of supply of service shall be the location of recipient of service. Where the location of recipient of service is not known, the place of supply shall be the location of supplier of service.

Q 28. What is the place of supply in respect of goods that are required to be made physically available for providing the service?

Ans. As per Section 10 (3) of the Revised Model IGST Law the place of supply of service in respect of goods that are required to be made physically available by the recipient of service to the supplier of service shall be the location where the services are actually performed.

Q 29. What is the place of supply of services provided from a remote location using electronic means on goods?

Ans. As per Section 10 (3) of the Revised Model IGST Law where services are provided in respect of goods from a remote location by electronic means, the place of supply shall be the location where the goods are actually located. Example, if Software Ltd, a company based out of Bangalore, awards online maintenance contract of its servers located in Mumbai office to X INC, a company based out of USA, and as per the terms of the online maintenance X INC shall be required to perform regular maintenance from USA using Internet, then the place of supply of maintenance services shall be Mumbai.

Likewise, if Software Ltd gets an order from a Japanese Bank, based out of Tokyo, to monitor load of transactions on the servers located in Tokyo using Internet facilities, then the place of supply of such monitoring services shall be at Tokyo.

Q 30. What is the place of supply of service in relation to an immovable property, hotel accommodation?

Ans. Section 10 (4) of the Revised Model IGST Law provides that the place of supply service in relation to an immovable property, including services supplied in this regard by experts and estate agents, supply of hotel accommodation by a hotel, inn, guest house, club or campsite, by whatever name called, grant of rights to use immovable property, services for carrying out or co-ordination of construction work, including architects or interior decorators, shall be the place where the immovable property is located or intended to be located.

Example - If Mr. A of New York, is constructing a house in New York and appoints Mr. B of Delhi to provide architectural services with regard proposed construction of house located in New York, then the place of supply of such architectural services shall be New York.

Q 31. What will be the place of supply for services in relation to organizing events?

Ans. As per Section 10 (5) of the Revised Model IGST Law the place of supply of services supplied by way of admission to, or organization of, a cultural, artistic, sporting, scientific, educational, or entertainment event, or a celebration, conference, fair, exhibition, or similar events, and of services ancillary to such admission will be the place where the event is actually held.

Example: If Company X in India pays for conference to be attended by its CEO held in London, the place of supply of service will London.

Q 32. Which are the specified services where the place of provision is the location of the service provider?

Ans. The place of provision of service is the location of the service provider for the following services

- (a) services supplied by a banking company, or a financial institution, or anon-banking financial company, to account holders;
- (b) intermediary services;
- (c) services consisting of hiring of means of transport other than aircrafts and vessels except yachts, upto a period of one month.

Example: If XY Bank in USA charges loan processing charges to AB Co. located in India, the place of supply of service will be USA.

Q 33. What is the place of supply of services by way of transportation of goods?

Ans. The place of supply of services of transportation of goods, other than byway of mail or courier will be the place of destination of the goods.

Example: If PQ shipping Co. located in India charges ocean freight charges for transport of goods to Germany for a customer located in India, the place of supply of service will be Germany.

Q 34. What is the place of supply of services provided on board a conveyance such as aircraft?

Ans. Section 9(11) provides that the place of supply of services on board a conveyance during the course of passenger transport will be the location of the first scheduled point of departure of that conveyance for the journey.

Example: Air India departing from Mumbai to Paris providing food to its passengers, the place of supply will be Mumbai (first scheduled point of departure). For return journey, the place of supply shall be Paris.

Q 35. What is the place of supply of online information and database access or retrieval service?

Ans. The place of supply of the “online information and database access or retrieval services” services will be location of recipient of service. However, person receiving such service will be deemed to be located in taxable territory (i.e. India) if any two of the following non-contradictory conditions are fulfilled:

- (i) the location of address presented by the recipient of service via internet is in taxable territory;
- (ii) the credit card or debit card or store value card or charge card or smart card or any other card by which the recipient of service settles payment has been issued in the taxable territory;

- (iii) the billing address of recipient of service is in the taxable territory;
- (iv) the internet protocol address of the device used by the recipient of service is in the taxable territory;
- (v) the bank of recipient of service in which the account used for payment is maintained is in the taxable territory;
- (vi) the country code of the subscriber identity module (SIM) card used by the recipient of service is of taxable territory;
- (vii) the location of the fixed land line through which the service is received by the recipient is in taxable territory.

Example of such services are advertising on the internet; providing cloud services; provision of e-books, movie, music, software and other intangibles via telecommunication networks or internet; providing data or information, retrievable or otherwise, to any person, in electronic form through a computer network; online supplies of digital content (movies, television shows, music, etc.); digital data storage; online gaming.

MCQ

Q 1. Which of the following supply involving movement of goods is an intra-State supply?

- (a) Location of supplier in Kerala and place of supply in Tamil Nadu
- (b) Location of supplier in Karnataka and place of supply in Karnataka
- (c) Location of supplier in Kerala and place of supply in Andhra Pradesh
- (d) None of the above

Ans. (b) Location of supplier in Karnataka and place of supply in Karnataka.

Q 2. Place of supply in case of installation of elevator is

- (a) Where the movement of elevator commences from the supplier's place
- (b) Where the delivery of elevator is taken
- (c) Where the elevator is installed
- (d) Where address of the recipient is mentioned in the invoice

Ans. (c) Where the elevator installed

Q 3. Place of supply of food taken onboard at Delhi for an aircraft departing from Delhi to Bangalore via Hyderabad is

- (a) Address of the aircraft carrier mentioned on the invoice of the supplier
- (b) Delhi

- (c) Jaipur
- (d) Hyderabad

Ans. (b) Delhi

Q 4. In case of any ambiguity where place of supply cannot be determined as provided in Section 5(2) to 5(5) of the Revised Model IGST Law who will determine the place of supply?

- (a) Central Government on recommendation of the Council
- (b) State and Central Government on recommendation of the Council
- (c) State Government
- (d) Central Government

Ans. (a) Central Government on recommendation of the Council

Q 5. What is location of supply in case of importation of goods?

- (a) Customs port where the goods are cleared
- (b) Location of the importer
- (c) Place where the goods are delivered after clearance from customs port
- (d) Owner of the goods

Ans. (b) Location of importer

Q 6. Real estate agent in Delhi charges brokerage fee to Company a located in Chandigarh for assistance in getting a commercial property in Kolkata. Which is the place of supply in this case?

- (a) Delhi
- (b) Chandigarh
- (c) Kolkata

Ans. (c) Kolkata

Q 7. What is the place of supply of service where a restaurant provides catering service at the premise of the customer?

- (a) Address of the restaurant from where the food is supplied
- (b) Customer premise where catering service is provided

Ans. (b) Customer premise where catering service is provided.

Q 8. Mr. X a resident from Pune conducts training for employees of P Ltd. being a registered person under GST based out in Chennai at a resort in Darjeeling. The place of supply in this case is

- (a) Chennai
- (b) Pune
- (c) Darjeeling

Ans. (a) *Chennai*

Q 9. Place of supply of service for DTH by ABC Pvt. Ltd. located in Mumbai to customer in Patna is

- (a) Mumbai
- (b) Patna

Ans. (b) *Patna*

Q 10. Mr. X of Hyderabad not having bank account takes a demand draft in Kolkata from ABC Bank for his visa purpose. The place of supply is

- (a) Hyderabad
- (b) Kolkata

Ans. (b) *Kolkata*

Q 11. The provider of AMC service outside India has entered into an agreement for an aircraft company PQR located in India AMC. The service provider provides repair service to the aircraft when it was in India. The place of service in this case is

- (a) Outside India
- (b) India

Ans. (b) *India*

Q 12. If XYZ Ltd a company based out of Bangalore, awards online maintenance contract of its servers located in Mumbai office to Y INC, a company based out of USA, and as per the terms of the online maintenance X INC shall be required to perform regular maintenance from USA using Internet, then the place of supply is

- (a) Bangalore
- (b) Mumbai
- (c) USA

Ans. (b) *Mumbai*

- Q 13. Mr. Y residing in Ahmedabad appoints an architect in Delhi to provide Indian traditional home design for his proposed construction at Los Angeles, the place of supply of service is
- (a) Los Angeles
 - (b) Ahmedabad
 - (c) Delhi

Ans. (a) Los Angeles

- Q 14. If NM shipping Co. located in Chennai charges ocean freight charges for transport of goods to California for a customer located in Bangalore, the place of supply of service will be
- (a) Chennai
 - (b) California
 - (c) Bangalore

Ans. (b) California

Chapter - IV

Input Tax Credit

FAQ

Claim of Input Tax credit, Provisional Acceptance, Matching, reversal and reclaim of input tax credit or reduction in output tax liability (Section 13)

- Q 1. Whether the registered taxable person shall be entitled to take credit of input tax credit as self-assessed in the return and shall be credited to Electronic credit ledger on final basis or Provisional basis?
- Ans. The registered taxable person shall be entitled to take credit of input tax credit as self-assessed in the return and shall be credited to Electronic credit ledger on provisional basis.
- Q 2. Whether Provisional Input Tax credit can be utilized against any tax liability?
- Ans. The provisional Input Tax credit can be utilized only against the self-assessed output tax liability and not against any other tax liabilities.
- Q 3. Why is it required to file GST returns and payment of GST by supplier required for sanctioning Input Tax Credit to recipient?
- Ans. The supplier's GST tax invoice and subsequent entry of such tax in his returns has to match with the recipient's claim for Input Tax Credit. Such payment of GST by supplier has to be confirmed for sanctioning Input Tax Credit finally.
- Q 4. What happens in case of mis-match of supplier's tax payment with returns and recipient's claim for Input Tax credit?
- Ans. If the details of recipient's claim for Input Tax Credit and the details of returns and tax payment of supplier don't match, such Input Tax Credit shall be added to output tax liability in the hands of receiver. The recipient shall be eligible to reduce if the supplier declares / rectifies the invoice within the maximum time limit specified.

Q 5. Whether interest is leviable in the hands of the recipient in case of mismatch of credit?

Ans. Yes, interest shall be leviable from the date of availing the credit till the corresponding additions to be made. In case the supplier pays the output tax with interest then the interest shall be refunded to the recipient and will not exceed the interest as paid by supplier.

Q 6. Whether the Input Tax credit as credited in Electronic Credit ledger can be utilized for payment of Interest, penalty, fees?

Ans. No the Input tax credit as credited in Electronic Credit ledger cannot be utilized for payment of Interest, penalty, fees

Transfer of Input Tax Credit (Section 14)

Q 7. How will the credit of IGST be adjusted against CGST?

Ans. In case of utilization of IGST credit against the CGST payable, IGST collected will reduce from IGST Account and will be transferred to CGST Account by Central Government.

Q 8. How will the credit of IGST be adjusted against SGST?

Ans. In case of utilization of IGST credit against the SGST payable, IGST collected will reduce from IGST Account and will be transferred to SGST Account by State Government.

Apportionment of Tax and Settlement of Funds

FAQ

Apportionment of Tax (Section 15)

Q1. What is the mechanism of IGST apportionment between Centre and State?

Ans. The IGST paid on the inter-state supplies to:

- (a) An unregistered person
- (b) Composition dealer
- (c) Taxable Person who is not eligible for input tax credit
- (d) Taxable Person who does not avail credit within specified period

will be apportioned to the Central Government based on the rate of CGST on similar intra state supply and the balance will be apportioned to the State Government where such supply takes place. The appropriate State will be determined based on Section 7 to Section 10 of the IGST Act which provides for Place of Supply of Goods / Services.

Q2. How will the IGST portion be distributed to the extent of State share if the place of supply cannot be determined?

Ans. Such State share of tax will be distributed in the proportion of the supplies made by the taxable person to each of the States during the year to which such tax relates to.

Q3. How will the IGST portion be distributed if distribution as mentioned under response to Q2 is not possible since the taxable person cannot be identified?

Ans. Such State share of tax will then be distributed based on the order to be made by the President based on the provisions contained in the Constitution of India.

Q4. How will the Penalty, Interest etc. paid on IGST be distributed?

Ans. The penalty, interest etc. will be distributed the same way as the IGST is distributed.

MCQ

- Q1. Out of IGST paid to the Central Government, which of the following must be apportioned based on tax rate equivalent to the CGST on similar intra-state supply?
- (a) Inter-State supply of goods and services to an unregistered person.
 - (b) Inter-State supply of goods and services to a taxable person paying tax under sec.9 of the CGST Act, 2016.
 - (c) Inter-State supply of good and services to taxable person not eligible for input tax credit.
 - (d) All of the above.

Ans. (d) *All of the above*

- Q2. Can IGST amount apportioned to a State, if subsequently found refundable to any person and refunded to such person, be reduced from the amount apportioned to such state?
- (a) Yes
 - (b) No
 - (c) Partially
 - (d) None of the above

Ans. (a) *Yes*

- Q3. Out of the IGST paid to the Central Government in respect of import of goods or services, if the registered taxable person does not avail the said credit within the specified period, and so remains in the IGST account, what is the treatment?
- (a) Refund it back to the taxable person.
 - (b) Can be claimed after the expiry of the specified period.
 - (c) Apportion to the state where such supply takes place.
 - (d) None of the above.

Ans. (c) *Apportion to the state where such supply takes place.*

- Q4. The provisions of apportionment of tax also apply to
- (a) Apportionment of interest
 - (b) Apportionment of penalty
 - (c) Compounding amount realized in connection with tax so apportioned.
 - (d) All of the above

Ans. (d) *All of the above*

Chapter - VI

Zero Rated Supply

FAQ

Zero Rated Supply (Section 16)

- Q1. What is the meaning of the term “Zero Rated Supply”?
- Ans. “Zero Rated Supply” refers to taxable supplies made to SEZ units / developers or exports of goods and / or services.
- Q2. What is the relevance of zero rated supplies?
- Ans. Zero Rated Supplies refers to supplies which are not liable to tax but the supplier is not required to reverse the credit relating to such supplies. This concept helps in ensuring that exports are tax free and the tax credit chain is not broken.
- Q3. Will export of goods be liable to GST?
- Ans. Export of goods will not be liable to GST subject to procedural compliance of executing bond with the jurisdictional GST officer. A taxable person also has an option to pay IGST on export of goods and claim the same as refund in such manner as may be prescribed by rules.
- Q4. Can SEZ unit / Developers claim refund of IGST charged by the supplier?
- Ans. Yes, Revised Model IGST Law allow the SEZ unit / developer receiving zero rated supplied to claim refund of tax charged by their suppliers.

MCQ

- Q1. Zero rated supply includes
- (a) Export of goods and services.
 - (b) Supply of goods and services to a SEZ developer or SEZ Unit
 - (c) Only (a)
 - (d) (a) and (b)
- Ans. (d) (a) and (b)

- Q2. Is the SEZ developer or SEZ unit receiving zero rated supply eligible to claim refund of IGST paid by the registered taxable person on such supply?
- (a) Yes
 - (b) No
 - (c) Partially yes

Ans. (a) Yes

- Q3. A registered taxable person is eligible to claim refund in respect of export of goods and services in which of the following cases:
- (a) Under bond, without payment of IGST and claim refund of unutilized input tax credit.
 - (b) On payment of IGST and claim refund of IGST paid on such goods and services.
 - (c) None of the above
 - (d) Both (a) and (b)

Ans. (d) Both (a) and (b)

- Q4. The supply of goods to SEZ unit is treated as _____ in the hands of the supplier:
- (a) Exempt Supply – Reversal of credit
 - (b) Deemed Taxable Supply – No reversal of credit
 - (c) Export of Supplies
 - (d) Non Taxable Supply – Outside the Scope of GST

Ans. (b) Deemed Taxable Supply – No reversal of credit

Chapter - VII

Transitional Provisions

FAQ

Import of services or inter-State supply of goods and/or services made on or after the appointed day (Section 21)

- Q 1. In case of import of services and inter-State supplies which have been initiated after the appointed day, tax shall be paid under which tax regime?
- Ans. Where import of services or the inter-State supply of goods or services has been made after the appointed day, tax shall be payable under the GST regime.
- Q 2. What are the circumstances under which tax shall not be payable under the GST regime for inter-State supply of goods/service or import of service after appointed date?
- Ans. Tax shall not be payable under the Act for inter-State supply of goods and service/ import of service if tax has been paid in full under the earlier law.
- Q 3. If tax on import of service/ interstate supply of goods or service is paid partly, what shall be the tax treatment for such transactions?
- Ans. In case tax has been paid partly on inter-State supply of goods and service/ import of service, the balance tax shall be payable under the GST regime

MCQ

- Q 1. In case of import of services and inter-State supplies which have been initiated prior to the appointed day, tax shall be paid under which tax regime?
- (a) Irrespective of the fact that the import of services or the inter-State of supply of goods or services has been initiated before the appointed day, tax shall be payable under the GST regime.
 - (b) New regime, only if the consideration is paid after the appointed date
 - (c) Old regime, only if the consideration is paid before the appointed date
 - (d) Old regime, since the transaction is initiated prior to the appointed date, irrespective of payment date
- Ans. (a) *Irrespective of the fact that the import of services or the inter-State of supply of goods or services has been initiated before the appointed day, tax shall be payable under the GST regime.*

- Q 2. If tax on import of service/ inter-State supply of goods or service is paid partly, what shall be the tax treatment for such transactions?
- (a) In case tax has been paid partly on inter-state supply of goods and service/ import of service, the balance tax shall be payable under the GST regime.
 - (b) Balance taxes have to be paid under the old regime
 - (c) Irrespective of taxes paid earlier, full taxes have to be paid under the GST regime
 - (d) Refund of earlier taxes can be claimed and full taxes have to be paid in the GST regime
- Ans. (a) In case tax has been paid partly on inter-State supply of goods and service/ import of service, the balance tax shall be payable under the GST regime.